

MSB Air Distribution

Finishes

Type/Description	Manufacturer	Pattern/line	Color	Notes
Paint	Sherwin Williams	Semi-Gloss	SW 7043 Worldy Gray	Office
Paint	Sherwin Williams	Semi-Gloss	UT Off-White (SW Custom)	Hallway
Paint	Sherwin Williams	Semi-Gloss	SW 6423 Ryegrass	Hallway
Paint	Sherwin Williams	Semi-Gloss	SW 6380 Humble Gold	Hallway
Paint	Sherwin Williams	Semi-Gloss	SW 6242 Bracing Blue	Hallway
Carpet	Interface Flooring	Furrows II	9223 Hops	Office (Existing)
Carpet	Interface Flooring	Furrows II	9212 Georgia Clay	Office
Base Cove	Roppe		P193 Black/Brown	All Areas
VCT	Armstrong	Imperial Texture	51810 Washed Linen	Hallway
Ceilings	Armstrong	Fine Fissured	1732 White	All Areas

Room Number	Carpet	Paint	Blinds
6.018	Y	Y	
6.018A	Y	Y	Y
6.018B	Y	Y	Y
6.018C	Y	Y	Y
6.018D	Y	Y	Y
6.018E	Y	Y	Y
6.018F	Y	Y	Y
6.018G	EXISTING	Y	
6.018H	Y	Y	
6.100	EXISTING	Y	
6.100A	Y	Y	
6.100B	Y	Y	
6.100C	VINYL	Y	
6.100D	Y	Y	
6.100E	Y	Y	
6.100F	Y	Y	Y
6.100G	Y	Y	Y
6.102	Y	Y	Y
6.104	Y	Y	Y
6.106	Y	Y	Y
6.108	Y	Y	Y
6.124	Y	Y	Y
6.126	Y	Y	Y
6.128	Y	Y	Y
6.130	RE-GLUE	Y	Y
6.130A	RE-GLUE	Y	Y
6.130B	RE-GLUE	Y	Y
6.132	Y	Y	
6.132A	Y	Y	
6.132B	Y	Y	Y
6.134	Y	Y	Y
6.134A	Y	Y	Y
6.136	Y	Y	Y

Room Number	Carpet	Paint	Blinds
6.138	Y	Y	Y
6.139	Y	Y	Y
6.140	Y	Y	Y
6.141	Y	Y	Y
6.142	Y	Y	Y
6.144	Y	Y	Y
6.146	Y	Y	Y
6.148	PATCH AS REQ	Y	Y
6.150	PATCH AS REQ	Y	
6.152	VINYL	Y	Y
6.154	EXISTING	Y	Y
6.156	Y	Y	Y
6.158	Y	Y	Y
6.160	Y	Y	Y
6.161	Y	Y	Y
6.162	Y	Y	Y
6.164	Y	Y	Y
6.166	Y	Y	Y
6.168	Y	Y	Y
6.170	Y	Y	Y
6.172	Y	Y	Y
6.174	Y	Y	Y
6.178	Y	Y	Y
6.180	Y	Y	Y
6.182	Y	Y	Y
6.184	Y	Y	Y
6.200	EXISTING	Y	Y
6.200A	EXISTING	Y	
6.200B	EXISTING	Y	
6.200C	EXISTING	Y	
6.200D	EXISTING	Y	Y
6.200E	EXISTING	Y	Y
6.201	Y	Y	Y

Room Number	Carpet	Paint	Blinds
6.202	Y	Y	Y
6.204	Y	Y	Y
6.206	Y	Y	Y
6.210	EXISTING	Y	Y
6.212	Y	Y	Y
6.214	Y	Y	Y
6.216	Y	Y	Y
6.218	Y	Y	Y
6.219	Y	Y	Y
6.220	Y	Y	Y
6.222	Y	Y	Y
6.224	Y	Y	Y
6.226	Y	Y	Y
6.228	Y	Y	Y
6.230	Y	Y	Y
6.232	Y	Y	Y
6.240	Y	Y	Y
6.240A	Y	Y	Y
6.240B	Y	Y	Y
6.240C	Y	Y	Y
6.246	Y	Y	Y
6.246A	Y	Y	Y
6.246B	Y	Y	Y
6.250	Y	Y	Y
6.252	Y	Y	Y
6.254	Y	Y	Y
6.256	Y	Y	Y
6.258	Y	Y	Y
6.260	Y	Y	Y
6.262	Y	Y	Y
6.264	Y	Y	Y
6.264A	Y	Y	Y
6.270	Y	Y	Y

Room Number	Carpet	Paint	Blinds
6.270A	Y	Y	Y
6.272	Y	Y	Y
6.274	Y	Y	Y
6.278	Y	Y	Y
6.280	Y	Y	Y
6.282	Y	Y	Y
6.282A	Y	Y	Y
6.284	Y	Y	Y
6.284A	Y	Y	Y
6.284B	Y	Y	Y
6.290	Y	Y	Y
6.291	Y	Y	Y
6.292	Y	Y	Y
6.293	Y	Y	Y

SHERWIN-WILLIAMS 7403
713-529-6515

08/29/16
Order# 0243868

INTERIOR
HARMONY
EG-SHEL

ARCHITECTURAL
LATEX
STANDALONE

UTHSC UT OFF-WHITE
CUSTOM MANUAL MATCH

CCE*COLORANT	0Z	32	64	128
G2-New Green	-	1	-	-
R2-Maroon	-	1	-	-
Y3-Deep Gold	-	3	-	-

ONE GALLON
B09WB1051

EXTRA WHITE
650428204

BEDROOM

Non Returnable Tinted Color

CAUTION: To assure consistent color, always order enough paint to complete the job and intermix all containers of the same color before application. Mixed colors may vary slightly from

MECHANICAL

23 00 00	Basic Mechanical Requirements
23 05 29	Sleeves, Flashings, Supports and Anchors
23 05 53	Mechanical Identification
23 05 93	Testing, Adjusting and Balancing (TAB)
23 05 93A	Testing, Adjusting and Balancing (Contractor Responsibilities)
23 07 13	Ductwork Insulation
23 09 23	Direct Digital Control Systems
23 31 00	Ductwork
23 33 00	Ductwork Accessories
23 36 00	Air Terminal Units
23 37 00	Air Inlets and Outlets

Division 26 – Electrical

26 00 00	Basic Electrical Requirements
26 00 00.01	Electrical Demolition
26 05 00	Basic Electrical Materials and Method
26 05 19	Cable, Wire and Connectors, 600 Volts
26 05 29	Securing and Supporting Methods
26 05 33	Raceways, Conduit and Boxes
26 05 53	Electrical Identification
26 51 00	Interior and Exterior Lighting
28 31 00	Fire Alarm and Smoke Detection

For Construction
E&C Engineers & Consultants, Inc.
TX Firm Registration No: F-003068
Date: 3-3-2017
Engineer of Record: Heather Camden, PE
State: of Texas License No: 86883

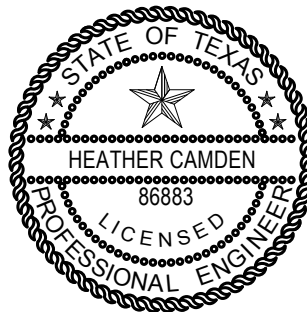

THE SEAL APPEARING ON THIS DRAWING WAS AUTHORIZED BY:

Digitally signed
by Heather
Camden
Date:
2017.03.03
11:00:55-06'00'
E&C Engineers & Consultants Inc.
Texas Firm Registration No: F-003068

SECTION 23 00 00
BASIC MECHANICAL REQUIREMENTS

PART 1 GENERAL

1.01 SECTION INCLUDES

- A. Basic Mechanical Requirements specifically applicable to Division 23 Sections, in addition to Division 01 - General Requirements.

1.02 RELATED DOCUMENTS:

- A. THE UNIFORM GENERAL CONDITIONS, SUPPLEMENTARY GENERAL CONDITIONS, and DIVISION 01 of the Specifications apply to the work specified in this Section.
- B. All work covered by this Section of these Specifications shall be accomplished in accordance with all applicable provisions of the Contract Documents and any addenda or directives which may be issued herewith, or otherwise.

1.03 GENERAL:

- A. The Contractor shall execute all work hereinafter specified or indicated on accompanying Drawings. Contractor shall provide all equipment necessary and usually furnished in connection with such work and systems whether or not mentioned specifically herein or on the Drawings.
- B. The Contractor shall be responsible for fitting his material and apparatus into the building and shall carefully lay out his work at the site to conform to the structural conditions, to avoid all obstructions, to conform to the details of the installation and thereby to provide an integrated satisfactory operating installation.
- C. The Mechanical, Electrical, and associated Drawings are necessarily diagrammatic by their nature, and are not intended to show every connection in detail or every pipe or conduit in its exact location. These details are subject to the requirements of standards referenced elsewhere in these specifications, and structural and architectural conditions. The Contractor shall carefully investigate structural and finish conditions and shall coordinate the separate trades in order to avoid interference between the various phases of work. Work shall be organized and laid out so that it will be concealed in furred chases and suspended ceilings, etc., in finished portions of the building, unless specifically noted to be exposed. All exposed work shall be installed parallel or perpendicular to the lines of the building unless otherwise noted.
- D. When the mechanical and electrical Drawings do not give exact details as to the elevation of pipe, conduit and ducts, the Contractor shall physically arrange the systems to fit in the space available at the elevations intended with proper grades for the functioning of the system involved. Piping, exposed conduit and the duct systems are generally intended to be installed true and square to the building construction, and located as high as possible against the structure in a neat and workmanlike manner. The Drawings do not show all required offsets, control lines, pilot lines and other location details. Work shall be concealed in all finished areas.

- 1.04 DEFINITIONS: (Note: These definitions are included here to clarify the direction and intention of this specification. The list given here is not by any means complete. For further clarification as required, contractor shall contact the designated owner's representative.)

- A. CONCEALED / EXPOSED: Concealed areas are those areas which cannot be seen by the building occupants. Exposed areas are all areas which are exposed to view by the building occupants, including under counters, inside cabinets and closets, plus all mechanical rooms.
- B. General Requirements: The provisions of requirements of other Division 01 sections apply to entire work of contract and, where so indicated, to other elements which are included in project. Basic contract definitions are included in the General Conditions.
- C. Indicated: The term "indicated" is a cross reference to graphic representations, notes or schedules on drawings, to other paragraphs or schedules in the Specifications, and to similar means of recording requirements on contract documents. Where terms such as "shown", "noted", "scheduled", and "specified" are used in lieu of "indicated", it is for the purpose of helping reader locate the cross reference, and no limitation of location is intended except as specifically noted.
- D. Directed, requested, etc.: Where not otherwise explained, terms such as "directed", "requested", "authorized", "selected", "approved", "required", "accepted", and "permitted" mean directed by Architect/Engineer", "requested by Architect/Engineer" and similar phrases. However, no such implied meaning will be interpreted to extend Architect's/Engineer's responsibility into Contractor's area of construction supervision and job safety.
- E. And/Or: Where "and/or" is used in these Specifications or on the Drawings, it shall mean "that situations exist where either one or both conditions occur or are required and shall not be interpreted to permit an option on the part of the Contractor.
- F. Approve: Where used in conjunction with Architect's/Engineer's response to submittals, requests, applications, inquiries, reports and claims by Contractor, the meaning of term "approved" will be held to limitations to Architect's/Engineer's responsibilities and duties as specified in General and Supplementary Conditions. In no case will "approval" by Architect/Engineer be interpreted as a release of Contractor from responsibilities to fulfill requirements of contract documents or to extend Architect's/Engineer's responsibility into Contractor's area of construction supervision and job safety.
- G. As required: Where "as required" is used in these Specifications or on the drawings, it shall mean "that situations exist that are not necessarily described in detail or indicated that may cause the contractor certain complications in performing the work described or indicated. These complications entail the normal coordination activities expected of the Contractor where multiple trades are involved and new or existing construction causes deviations to otherwise simplistic approaches to the work to be performed. The term shall not be interpreted to permit an option on the part of the Contractor to achieve the end result."
- H. Furnish:
 - 1. The term "furnish" is used to mean "supply and deliver to project site, ready for unloading, unpacking, assemble, installation, and similar operations."
 - 2. Where "furnish" applies to work for which the installation is not otherwise specified, "furnish" in such case shall mean "furnish and install."
- I. Install: The term "install" is used to describe operations at project site including "unloading, unpacking, assembly, erection, placing, anchoring, applying, working to dimension, finishing, curing, protecting, cleaning and similar operation."

- J. Provide: The term "provide" means "to furnish and install, complete and ready for intended use."

1.05 PERMITS, UTILITY CONNECTIONS AND INSPECTIONS:

- A. General: Refer to DIVISION 01 for construction phasing and time increments.
- B. Fees and Costs: Refer to Division 01 for payment requirements of fees and utility costs.
- C. All work performed on this project is under the authority of the State of Texas, therefore no local construction fees or construction permits will be required except as may be required for new service taps, or new or modified connections to City controlled services. If inspections by City personnel are specifically required by this document, refer to Division 01 for responsibility.
- D. Compliance: The Contractor shall comply in every respect with all requirements of National Fire Protection Association, local Fire Department regulations and utility company requirements. In no case does this relieve the Contractor of the responsibility of complying with these Specifications and Drawings where specified conditions are of higher quality than the requirements of the above-specified authorities. Where requirements of the Specifications and Drawings are more lenient than the requirements of the above authorities having jurisdiction, the Contractor shall make installations in compliance with the requirements of the above authorities with no extra compensation.

1.06 CONTRACT DOCUMENTS:

- A. All dimensional information related to new structures shall be taken from the appropriate Drawings. All dimensional information related to existing facilities shall be taken from actual measurements made by the Contractor on the site.
- B. The interrelation of the Specifications, the Drawings, and the schedules are as follows: The Specifications determine the nature and setting of the several materials, the Drawings establish the quantities, dimensions and details, and the schedules give the performance characteristics. If the Contractor requires additional clarification, he shall request it in writing, following the contractually prescribed information flow requirements.
- C. Should the Drawings or Specifications conflict within themselves, or with each other, the better quality, or greater size or quantity of work or materials shall be performed or furnished.

1.07 FUTURE WORK

- A. Provide for future work under requirements of Section 01 11 00.

1.08 SUBMITTALS

- A. Refer to Uniform General Conditions.
- B. Proposed Products List: Include Products specified in the following Sections:
 - 1. Section 23 05 29 - Sleeves, Flashings, Supports and Anchors
 - 2. Section 23 05 53 - Mechanical Identification

3. Section 23 05 93 – Testing, Adjusting and Balancing (TAB)
 4. Section 23 05 93A – Testing, Adjusting and Balancing Contractor Responsibilities
 5. Section 23 07 13 - Ductwork Insulation
 6. Section 23 09 23 - Direct Digital Control Systems
 7. Section 23 31 00 - Ductwork
 8. Section 23 33 00 - Ductwork Accessories
 9. Section 23 36 00 - Air Terminal Units
 9. Section 23 37 00 - Air Inlets and Outlets
- C. Submit shop drawings and product data grouped to include complete submittals of related systems, products, and accessories in a single submittal.
- D. Mark dimensions and values in units to match those specified.
- E. Submit Fabrication Drawings whenever (1) equipment proposed varies in physical size and arrangement from that indicated on the Drawings, thus causing rearrangement of equipment space, (2) where tight spaces require extreme coordination between ductwork, piping, conduit, and other equipment, (3) where called for elsewhere in these Specifications; and (4) where specifically requested by the Architect/Engineer. Fabrication Drawings shall be made at no additional charge to the Owner or the Architect/Engineer.
- F. All required Fabrication Drawings, except as noted otherwise, shall be prepared at a scale of not less than 1/4" = 1'-0". Fabrication Drawings for ductwork, air handling units, and sections in Mechanical Rooms shall be drawn at a minimum scale of 3/8" = 1'-0". Submit three blue-line prints of each Fabrication Drawing to the Architect/Engineer for review. Reproduction and submittal of the Construction Documents is not acceptable. The Architect/Engineer will review the drawing and return one print with comments.

1.09 SUBSTITUTION OF MATERIALS AND EQUIPMENT:

- A. Refer to General Conditions for substitution of materials and equipment.
- B. General: Within thirty days after the date of contract award or work order, whichever is later, and before purchasing or starting installation of materials or equipment, the Contractor shall submit for review, a complete list of suppliers, contractors and manufacturers for all materials and equipment which will be submitted for incorporation into the project. The list shall be arranged in accordance with the organization of the Specifications. This initial list shall include the manufacturer's name and type or catalog number as required to identify the quality of material or equipment proposed. This list will be reviewed by the Engineer and the Owner and will be returned to the Contractor with comments as to which items are acceptable without further submittal data and which items will require detailed submittal data for further review and subsequent approval. The initial list shall be submitted as herein specified. Materials and equipment requiring detailed submittal data shall be submitted with sufficient data to indicate that all requirements of these Specifications have been met and samples shall be furnished when requested. All manufacturer's data used as part of the

submittal shall have all inapplicable features crossed out or deleted in a manner that will clearly indicate exactly what is to be furnished.

- C. It is not the intent of the Drawings and/or Specifications to limit products to any particular manufacturer nor to discriminate against an "APPROVED EQUAL" product as produced by another manufacturer. Some proprietary products are mentioned to set a definite standard for acceptance and to serve as a reference in comparison with other products. When a manufacturer's name appears in these Specifications, it is not to be construed that the manufacturer is unconditionally acceptable as a provider of equipment for this project. The successful manufacturer or supplier shall meet all of the provisions of the appropriate specification(s).
- D. The specified products have been used in preparing the Drawings and Specifications and thus establish minimum qualities with which substitutes must at least equal to be considered acceptable. The burden of proof of equality rests with the Contractor. The decision of the designer is final.
- E. When requested by the Architect/Engineer, the Contractor shall provide a sample of the proposed substitute item. In some cases, samples of both the specified item and the proposed item shall be provided for comparison purposes.
- F. Timeliness: The burden of timeliness in the complete cycle of submittal data, shop Drawings, and sample processing is on the Contractor. The Contractor shall allow a minimum of six (6) weeks time frame for review of each submission by the office of the design discipline involved after receipt of such submissions by that design discipline. The Contractor is responsible for allowing sufficient time in the construction schedule to cover the aforementioned cycles of data processing, including time for all resubmittal cycles on unacceptable materials, equipment, etc. covered by the data submitted. Construction delays and/or lack of timeliness in the above regard are the responsibility of the Contractor and will not be considered in any request for scheduled construction time extensions and/or additional costs to the Owner.
- G. All equipment installed on this project shall have local representation, local factory authorized service, and a local stock of repair parts.
- H. Acceptance of materials and equipment will be based on manufacturer's published data and will be tentative subject to the submission of complete shop Drawings indicating compliance with the contract documents and that adequate and acceptable clearances for entry, servicing, and maintenance will exist. Acceptance of materials and equipment under this provision shall not be construed as authorizing any deviations from the Specifications, unless the attention of the Architect/Engineer has been directed in writing to the specific deviations. Data submitted shall not contain unrelated information unless all pertinent information is properly identified.
- I. Certification: The Contractor shall carefully examine all data forwarded for approval and shall sign a certificate to the effect that the data has been carefully checked and found to be correct with respect to dimensions and available space and that the equipment complies with all requirements of the Specifications.
- J. Physical Size of Equipment: Space is critical; therefore, equipment of larger sizes than shown, even though of specified manufacturer, will not be acceptable unless it can be demonstrated that ample space exists for proper installation, operation, and maintenance.
- K. Materials and Equipment Lists: Eight (8) copies of the list of materials and equipment, the name of manufacturer, trade name, type, and catalog number shall be submitted to the

Architect/Engineer. The lists shall be accompanied by eight (8) sets of pictorial and descriptive data derived from the manufacturers' catalogs, sales literature, or incorporated in the Shop Drawings.

- L. Should a substitution be accepted, and should the substitute material prove defective, or otherwise unsatisfactory for the service intended within the guarantee period, this material or equipment shall be replaced with the material or equipment specified at no additional cost to the Owner.

1.10 MATERIALS AND WORKMANSHIP:

- A. All materials, unless otherwise specified, shall be new, free from all defects, suitable for the intended use, and of the best quality of their respective kinds. Materials and equipment shall be installed in accordance with the manufacturer's recommendations and the best standard practice for the type of work involved. All work shall be executed by mechanics skilled in their respective trades, and the installations shall provide a neat, precise appearance. Materials and/or equipment damaged in shipment or otherwise damaged prior to installation shall not be repaired at the job site but shall be replaced with new materials and/or equipment.
- B. The responsibility for the furnishing of the proper equipment and/or material and seeing that it is installed as intended by the manufacturer, rests entirely upon the Contractor who shall request advice and supervisory assistance from the representative of specific manufacturers during the installation.

1.11 FLAME SPREAD PROPERTIES OF MATERIALS:

- A. Materials and adhesives incorporated in this project to be installed within return air plenums shall conform to NFPA Standard 255, "Method of Test of Surface Burning Characteristics of Building Materials" and NFPA 90. The classification shall not exceed a flame spread rating of 25 for all materials, adhesives, finishes, etc., specified for each system, and shall not exceed a smoke developed rating of 50.

1.12 REGULATORY REQUIREMENTS

- A. The "Authority Having Jurisdiction" over the project described by these documents is the Owner, as an Agency of the State of Texas. As such, it is required that the installation shall meet the minimum standards prescribed in the latest editions of the following listed codes and standards, which are made a part of these Specifications. All referenced codes and standards shall be those current at the date of issue of the design documents.
- B. National Fire Protection Association Standards (NFPA):
 - 1. NFPA No. 13, Sprinkler System, Installation
 - 2. NFPA No. 14, Standpipes and Hose Systems
 - 3. NFPA No. 20, Centrifugal Fire Pumps
 - 4. NFPA No. 37, Stationary Combustion Engines & Gas Turbines
 - 5. NFPA No. 45, Fire Protection for Laboratories Using Chemicals
 - 6. NFPA No. 51, Welding & Cutting, Oxygen-Fuel Gas Systems

7. NFPA No. 54, Gas Appliances, Piping, National Fuel Gas Code
 8. NFPA No. 70, National Electrical Code
 9. NFPA No. 72D, Proprietary Signaling Systems
 10. NFPA No. 78, Lightning Protection Code
 11. NFPA No. 90A, Air Conditioning Systems
 12. NFPA No. 91, Blower & Exhaust Systems
 13. NFPA No. 99, Health Care Facilities
 14. NFPA No. 101, Life Safety Code
 15. NFPA No. 200, Series, Building Construction
 16. NFPA No. 255, Method of Test of Surface Burning Characteristics of Building Materials
 27. NFPA No. 258, Standard Research Test Method for Determining Smoke Generation of Solid Materials
- C. American National Standards Institute (ANSI):
1. A40.8, National Plumbing Code
 2. B31.1, Power Piping
 3. B9.1, Safety Code for Mechanical Refrigeration
- D. American Gas Association Publications (AGA): Directory of Approved Gas Appliances and Tested Accessories
- E. American Society of Mechanical Engineers (ASME): Boiler and Pressure Vessel Codes
- F. Air Conditioning and Refrigeration Institute Standards (ARI): All standards related to refrigeration and air conditioning equipment and piping furnished under these Specifications.
- G. Sheet Metal and Air Conditioning Contractors National Association, Inc. (SMACNA): All current editions of applicable manuals and standards (See Sections 23 31 00.UT and 23 33 00.UT).
- H. Air Moving and Conditioning Association (AMCA): All current editions of applicable manuals and standards.
- I. American Society of Testing Materials (ASTM): All current editions of applicable manuals and standards.
- J. American Water Works Association (AWWA): All current editions of applicable manuals and standards.

- K. National Electrical Manufacturers' Association (NEMA): All current editions of applicable manuals and standards.
- L. City of Houston, Fire Department as may be applicable to construction on this site.
- M. International Building Code, (Includes the International Mechanical and International Plumbing Codes)
- N. Texas Occupational Safety Act: All applicable safety standards
- O. Occupational Safety and Health Act (OSHA)
- P. ADA and ANSI Standards: All work shall be in accord with all regulations and requirements of the Standards and Specifications for Handicapped and Disabled for the Construction of Public Buildings and Facilities in the State of Texas Usable by Physically Handicapped and Disabled persons, ANSI Standards and the requirements of the American Disabilities Act.
- Q. Texas State Fire Marshal Rules
- R. State Energy Code
- S. Refer to Specification Sections hereinafter bound for additional Codes and Standards.
- T. All materials and workmanship shall comply with all applicable state and national codes, Specifications, and industry standards. In all cases where Underwriters' Laboratories, Inc. have established standards for a particular type material, such material shall comply with these standards. Evidence of compliance shall be the UL "label" or "listing" under Re-Examination Service.
- U. The Contract Documents are intended to comply with the aforementioned rules and regulations; however, some discrepancies may occur. Where such discrepancies occur, the Contractor shall immediately notify the Architect/Engineer in writing of said discrepancies and apply for an interpretation. Should the discovery and notification occur after the execution of a contract, any additional work required for compliance with said regulations shall be paid for as covered by Division 01 of these Contract Documents, providing no work of fabrication of materials has been accomplished in a manner of noncompliance. Should the Contractor fabricate and/or install materials and/or workmanship in such a manner that does not comply with the applicable codes, rules and regulations, the Contractor who performed such work shall bear all costs arising in correcting these deficiencies to comply with said rules and regulations.

1.13 GENERAL MATERIALS AND EQUIPMENT REQUIREMENTS:

- A. Storage at Site: The Contractor shall not receive material or equipment at the job site until there is suitable space provided to properly protect equipment from rust, drip, humidity, and dust damage.
- B. Capacities shall be not less than those indicated but shall be such that no component or system becomes inoperative or is damaged because of startup or other overload conditions.
- C. Conformance with Agency Requirements: Where materials or equipment are specified to be approved, listed, tested, or labeled by the Underwriters' Laboratories, Inc., or constructed and/or tested in accordance with the standards of the American Society of Mechanical Engineers or the Air Moving and Conditioning Association, the Contractor shall submit proof

that the items furnished under this Section of the Specifications conform to such requirements. The label of the Underwriters Laboratories, Inc., applied to the item will be acceptable as sufficient evidence that the items conform to such requirements. The ASME stamp or the AMCA label will be acceptable as sufficient evidence that the items conform to the respective requirements.

- D. Nameplates: Each major component of equipment shall have the manufacturer's name, address, and catalog number on a plate securely attached to the item of equipment. All data on nameplates shall be legible at the time of Final Inspection.
- E. Prevention of Rust: Standard factory finish will be acceptable on equipment specified by model number; otherwise, surfaces of ferrous metal shall be given a rust inhibiting coating. The treatment shall withstand 200 hours in salt spray fog test, in accordance with Method 6061 of Federal Standard No. 141. Immediately after completion of the test, the specimen shall show no signs of wrinkling or cracking and no signs of rust creepage beyond 1/8" on either side of the scratch mark. Where rust inhibitor coating is specified hereinafter, any treatment that will pass the above test is acceptable unless a specific coating is specified except that coal tar or asphalt type coating will not be acceptable unless so stated for a specific item. Where steel is specified to be hot-dip galvanized, mill-galvanized sheet steel may be used provided all raw edges are painted with a zinc-pigmented paint conforming to Military Specification MIL-P-26915.
- F. Protection from Moving Parts: Belts, pulleys, chains, gears, couplings, projecting set screws, keys, and other rotating parts shall be fully enclosed or properly guarded for personnel protection.
- G. Verification of Dimensions: The Contractor shall be responsible for the coordination and proper relation of his work to the building structure and to the work of all trades. The Contractor shall visit the premises and become thoroughly familiar with all details of the work and working conditions, to verify all dimensions in the field, and to advise the Architect/Engineer of any discrepancy before performing any work. Adjustments to the work required in order to facilitate a coordinated installation shall be made at no additional cost to the Owner or the Architect/Engineer.

1.14 WALL, FLOOR AND CEILING PLATES:

- A. See Section 23 05 29.

1.15 SLEEVES, INSERTS, AND FASTENINGS:

- A. See Section 23 05 29.

1.16 PROJECT/SITE CONDITIONS

- A. Install Work in locations shown on Drawings, unless prevented by Project conditions.
- B. Prepare drawings showing proposed rearrangement of Work to meet Project conditions, including changes to Work specified in other Sections. Obtain permission of Architect/Engineer before proceeding.

1.17 MANUFACTURER'S RECOMMENDATIONS

- A. The manufacturer's published directions shall be followed in the delivery, storage, protection, installation, piping, and wiring of all equipment and material. The Contractor shall promptly

notify the Architect/Engineer, in writing, of any conflict between the requirements of the Contract Documents and the manufacturers' directions, and shall obtain the Architect/Engineer's instructions before proceeding with the work. Should the Contractor perform any such work that does not comply with the manufacturers' directions or such instructions from the Architect/Engineer, he shall bear all costs arising in connection with the deficiencies.

1.18 SPACE AND EQUIPMENT ARRANGEMENT:

- A. The size of mechanical and electrical equipment indicated on the Drawings is based on the dimensions of a particular manufacturer and a particular model. While other manufacturers and models may be acceptable, it is the responsibility of the Contractor to determine if the equipment he proposes to furnish will fit in the space with all adequate clearances. Fabrication Drawings shall be prepared when required by the Architect/Engineer or Owner to indicate a suitable arrangement.
- B. All equipment shall be installed in a manner to permit access to all surfaces. All valves, motors, drives, filters, and other accessory items shall be installed in a position to allow removal for service without disassembly of another part.

1.19 LARGE APPARATUS:

- A. Any large piece of apparatus which is to be installed in any space in the building, and which is too large to permit access through stairways, doorways, or shafts shall be brought to the job and placed in the space before the enclosing structure is completed. Following placement in the space, such apparatus shall be thoroughly, completely protected from damage as hereinafter specified.

1.20 PROTECTION:

- A. The Contractor shall at all times take such precautions as may be necessary to properly protect all materials and equipment from damage from the time of delivery until the completion of the work. This shall include the erection of all required temporary shelters and supports to adequately protect any items stored in the open on the site from the weather, the ground and surrounding work; the cribbing of any items above the floor of the construction; and the covering of items in the incomplete building with tarpaulins or other protective covering; the installation of electric heaters in electrical switchgear and similar equipment to prevent moisture damage. Failure on the part of the Contractor to comply with the above will be sufficient cause for the rejection of the items in question.
- B. Take particular care not to damage the building structure in performing work. All finished floors, step treads, and finished surfaces shall be covered to prevent any damage by workmen or their tools and equipment during the construction of the building.
- C. Equipment and materials shall be protected from rust both before and after installation. Any equipment or materials found in a rusty condition at the time of final inspection must be cleaned of rust and repainted as specified elsewhere in these Specifications.

1.21 COOPERATION BETWEEN TRADES AND WITH OTHER CONTRACTORS:

- A. Each trade, subcontractor, and/or Contractor must work in harmony with the various other trades (including Controls and Testing and Balancing), subcontractors and/or Contractors on the job as may be required to facilitate the progress to the best advantage of the job as a whole. Each trade, subcontractor, and/or Contractor must pursue its work promptly and

carefully so as not to delay the general progress of the job. This Contractor shall work in harmony with Contractors working under other contracts on the premises.

1.22 ELECTRICAL WIRING OF MOTORS AND EQUIPMENT:

- A. The Contractor shall note that the electrical design and Drawings are based on the equipment scheduled and indicated on the Drawings, and should any mechanical equipment be provided requiring changes to the electrical design, the required electrical changes shall be made at no cost to the Owner.
- B. The Electrical Trades shall provide all interconnecting wiring for the installation of all power. The Electrical Trades shall provide all disconnect switches as required for proper operation, as indicated on the Drawings or required by applicable code. All combination starters, individual starters, and other motor starting apparatus not specifically scheduled or specified as provided by the equipment manufacturer under the scope of Division 23, shall be provided under the scope of Division 26.
- C. The Mechanical Trades shall provide complete wiring diagrams indicating power wiring and interlock wiring. Diagrams shall be submitted to the Architect/Engineer for review within thirty (30) days after the submittals for equipment have been reviewed. Diagrams shall be based on accepted equipment and shall be complete full phase and interlock control Drawings, not a series of manufacturer's individual diagrams. After these diagrams have been reviewed by the Architect/Engineer, copies shall be transmitted to the Electrical Trades by the Contractor. They shall be followed in detail.

1.23 SUPERVISION:

- A. Each Contractor and subcontractor shall keep a competent superintendent or foreman on the job at all times. (Refer to the Uniform General Conditions for additional information concerning supervision.)
- B. It shall be the responsibility of each superintendent to study all Drawings and familiarize himself with the work to be done by other trades. He shall coordinate his work with other trades and before material is fabricated or installed, make sure that his work will not cause an interference with another trade. Where interferences are encountered, they shall be resolved at the job site by the superintendents involved. Where interferences cannot be resolved without major changes to the Drawings, the matter shall be referred to the A/E for ruling.

1.24 SITE OBSERVATION:

- A. Site observation by the Architect/Engineer is for the express purpose of verifying compliance by the Contractor with the Contract Documents, and shall not be construed as construction supervision nor indication of approval of the manner or location in which the work is being performed as being a safe practice or place.

1.25 PRECEDENCE OF MATERIALS

- A. The specifications determine the nature and setting of materials and equipment. The drawings establish quantities, dimensions and details.
- B. The installation precedence of materials shall be as follows. Note that if an interference is encountered, this shall guide the contractor in the determination of which trade shall be given the "Right-of-Way".

Building lines
Structural Members
Soil and Drain Piping
Condensate Drains
Vent Piping
Supply, Return, and Outside Air Ductwork
Exhaust Ductwork
HVAC Water and Steam Piping
Steam Condensate Piping
Fire Protection Piping
Natural Gas Piping
Domestic Water (Cold and Hot)
Refrigerant Piping
Electrical Conduit

1.26 CONNECTIONS FOR OTHERS:

- A. The Mechanical Contractor shall rough in for and make all gas, water, steam, sewer, etc. connections to all fixtures, equipment, machinery, etc., provided by others in accordance with detailed roughing-in Drawings provided by the equipment suppliers, by actual measurements of the equipment connections, or as detailed.
- B. After the equipment is set in place, this Contractor shall make all final connections and shall provide all required pipe, fittings, valves, traps, etc.
- C. Provide all air gap fittings required, using materials hereinbefore specified. In each service line connected to an item of equipment or piece of machinery, provide a shutoff valve. On each drain not provided with a trap, provide a suitable trap.
- D. All pipe fittings, valves, traps, etc., exposed in finished areas and connected to chrome plated lines provided by others shall be chrome plated to match.
- E. Provide all sheet metal ductwork, transition pieces, etc., required for a complete installation of vent hoods, fume hoods, etc., provided by others.

1.27 INSTALLATION METHODS:

- A. Where to Conceal: All pipes, conduits, etc., shall be concealed in pipe chases, walls, furred spaces, or above the ceilings of the building unless otherwise indicated.
- B. Where to Expose: In mechanical rooms, janitor's closets tight against pan soffits in exposed "Tee" structures, or storage spaces, but only where necessary, piping may be run exposed. All exposed piping shall be run in the most aesthetic, inconspicuous manner, and parallel or perpendicular to the building lines.
- C. Support: All piping, ducts and conduits shall be adequately and properly supported from the building structure by means of hanger rods or clamps to walls as herein specified.
- D. Maintaining Clearance: Where limited space is available above the ceilings below concrete beams or other deep projections, pipe and conduit shall be sleeved through the projection where it crosses, rather than hung below them in a manner to provide maximum above-floor clearance. Sleeves shall be as herein specified. Approval shall be obtained from the Architect/Engineer for each penetration.

- E. All pipe, conduits, etc., shall be cut accurately to measurements established at the building and shall be worked into place without springing or forcing. All ducts, pipes and conduits run exposed in machinery and equipment rooms shall be installed parallel to the building lines, except that piping shall be sloped to obtain the proper pitch. Piping, ducts and conduits run in furred ceilings, etc., shall be similarly installed, except as otherwise shown. Conduits in furred ceilings and in other concealed spaces shall be neatly grouped and racked indicating good workmanship. All conduit and pipe openings shall be kept closed until the systems are closed with final connections.
1. All piping not directly buried in the ground shall be considered as "interior piping".
 2. Prior to the installation of any ceiling material, gypsum, plaster, or acoustical board, the Contractor shall notify the construction inspector so that arrangement can be made for an inspection of the above-ceiling area about to be "sealed" off. The Contractor shall give as much advance notice as possible no less than 10 working days.
 3. All above-ceiling areas will be subject to a formal inspection before ceiling panels are installed, or installation is otherwise concealed from view. All mechanical and electrical work at and above the ceiling, including items supported by the ceiling grid, such as air inlets or outlets and lighting fixtures, shall be complete and installed in accordance with contract requirements, including power to lighting fixtures, fans, and other powered items. Adequate lighting shall be provided to permit thorough inspection of all above-ceiling items. The inspection will include representatives of the following: General Contractor and each Subcontractor having work above the ceiling, Architect/Engineer, Physical Plant, Resident Construction Manager's Construction Inspector(s), the Resident Construction Manager and Office of Facilities Planning and Construction (OFPC). Areas to be included and time of inspection shall be coordinated with the Construction Inspector.
 4. The purpose of this inspection is to verify the completeness and quality of the installation of the air conditioning systems, the electrical systems, the plumbing systems, and any other special above ceiling systems such as pneumatic tube, vacuum systems, fire sprinkler piping and cable tray systems. The ceiling supports (tee bar or lath) shall be in place so that access panel and light fixture locations are identifiable and so that clearances and access provisions may be evaluated.
 5. No ceiling materials may be installed until the resulting deficiency list from this inspection is worked off and the Construction Inspector has given approval.

1.28 RECORDS FOR OWNER:

- A. The Contractor shall maintain a set of "blueprint" prints in the Field Office for the sole purpose of recording "installed" conditions. Daily note all changes made in these Drawings in connection with the final installation including exact dimensioned locations of all new underground utilities, services and systems and all uncovered existing active and inactive piping outside the building.
- B. At Contract completion the Contractor shall provide a set of reproducible revised drawings per Division 01. The contractor shall transfer the information from the "blueprint" prints maintained as described above, and turn over this neatly marked set of reproducible Drawings representing the "as installed" work to the Architect/Engineers for verification and subsequent transmittal to the Owner. The Contractor shall refer to Division 01 of these

Specifications, and to the Uniform General Conditions, for additional information. These Drawings shall include as a minimum:

1. Addendum written drawing changes.
 2. Addendum supplementary drawings.
 3. Accurate, dimensioned locations of all underground utilities, services and systems.
 4. Identification of equipment work shown on Alternates as to whether alternates were accepted and work actually installed.
 5. Change Order written drawing changes.
 6. Change Order supplementary drawings.
- C. In addition to the above, the Contractor shall accumulate during the progress of the job the following data, in duplicate, prepared in a neat brochure or packet folder and turn over to the Architect/Engineer for review, and subsequent delivery to the Owner.
1. All warranties and guarantees and manufacturers' directions on equipment and material covered by the Contract.
 2. Two sets of operating instructions for heating and cooling and other mechanical and electrical systems. Operating instructions shall also include recommended preventative maintenance and seasonal changeover procedures.
 3. Valve tag charts and diagrams specified herein.
 4. Approved wiring diagrams and control diagrams representing "as installed" conditions.
 5. Copies of approved Shop Drawings.
 6. Any and all other data and/or drawings required as submittals during construction.
 7. Repair parts list of all major items and equipment including name, address and telephone number of local supplier or agent.
- F. All of the above data shall be submitted to the Architect/Engineer for approval, and shall be corrected as instructed by the Architect/Engineer.

1.29 ACCESS DOORS:

- A. General: This Contractor shall provide wall or ceiling access doors for unrestricted access to all concealed items of mechanical equipment or devices.
- B. Doors: Access doors mounted in painted surfaces shall be of Milcor (Inland-Ryerson Construction Products Company) manufacture, Style K for plastered surfaces and Style M or DW for non-plastered surfaces. The Style K doors shall be set so that the finished surface of the door is even with the finished surface of the adjacent finishes. Access doors mounted on tile surfaces shall be of similar construction as noted above, except they shall be of stainless steel materials. Access doors shall be a minimum of 12" x 12" in size.

1.30 OPERATION PRIOR TO COMPLETION:

- A. When any piece of mechanical equipment is operable and it is to the advantage of the Contractor to operate the equipment, he may do so, providing that he properly supervises the operation, and has the Construction Inspector's written permission to do so. The warranty period shall, however, not commence until such time as the equipment is operated for the beneficial use of the Owner, or date of substantial completion, whichever occurs first.
- B. Regardless of whether or not the equipment has or has not been operated, the Contractor shall properly clean the equipment, install clean filter media, properly adjust, and complete all deficiency list items before final acceptance by the Owner. The date of acceptance and performance certification will be the same date.

1.31 CHECKING AND TESTING MATERIALS AND/OR EQUIPMENT:

- A. Before the work is accepted, an authorized representative of the manufacturer of the installed materials and/or equipment shall personally inspect the installation and operation of his materials and/or equipment to determine that it is properly installed and in proper operating order. The qualifications of the representative shall be appropriate to the technical requirements of the installation. The qualifications of the representative shall be submitted to the owner for approval. The decision of the owner concerning the appropriateness of the representative shall be final. Testing and checking shall be accomplished during the course of the work where required by work being concealed, and at the completion of the work otherwise. In addition, the Contractor shall submit to the Architect/Engineer a signed statement from each representative certifying as follows: "I certify that the materials and/or equipment listed below have been personally inspected by the undersigned authorized manufacturer's representative and is properly installed and operating in accordance with the manufacturer's recommendations".
- B. Check inspections shall include plumbing equipment, heating, air conditioning, insulation, ventilating equipment, controls, mechanical equipment and such other items hereinafter specified or specifically designated by the Architect/Engineer.

1.32 TESTS:

- A. The Contractor shall make, at no additional cost to the Owner, any tests deemed necessary by the inspection departments having jurisdiction, and in the National Fire Protection Association, ASTM, etc. Standards listed. The Contractor shall provide all equipment, materials, and labor for making such tests. Reasonable amounts of fuel and electrical energy costs for system tests will be paid by the Owner. Fuel and electrical energy costs for system adjustment and tests which follow beneficial occupancy by the Owner will be borne by the Owner.
- B. Additional tests specified hereinafter under the various Specification Sections shall be made.
- C. The Construction Inspector shall be notified in writing at least 10 working days prior to each test and other Specification requirements requiring action on the part of the Construction Inspector. All equipment shall be placed in operation and tested for proper automatic control requirements before the balancing agency starts their work.
- D. Maintain Log of Tests as hereinafter specified.
- E. See Specifications hereinafter for additional tests and requirements.

1.33 LOG OF TESTS:

- A. All tests shall have pertinent data logged by the Contractor at the time of testing. Data shall include date, time, personnel, description, and extent of system tested, test conditions, test results, specified results, and other pertinent data. Data shall be delivered to the Architect/Engineer as specified under "Requirements for Final Acceptance". All Test Log entries shall be legibly signed by the Project Contractor or his authorized job superintendent.

1.34 COOPERATION AND CLEANUP:

- A. It shall be the responsibility of each trade to cooperate fully with the other trades on the job to help keep the job site in a clean and safe condition. At the end of each day's work, each trade shall properly store all of his tools, equipment and materials and shall clean his debris from the job. Upon the completion of the job, each trade shall immediately remove all of his tools, equipment, any surplus materials and all debris caused by that portion of the work.

1.35 CLEANING AND PAINTING:

- A. All equipment furnished and installed in exposed areas under Divisions 23 and 26 of these Specifications shall be cleaned, prepared, and painted according to the specification for the equipment.
- B. All purchased equipment furnished by the mechanical and electrical subcontractors shall be delivered to the job with a suitable factory protective finish with the colors hereinafter specified. The following materials shall not be painted: copper, galvanized metal, stainless steel, fiberglass, PVC, and PVDF.
- C. Before painting, materials and equipment surfaces shall be thoroughly cleaned of cement, plaster, and other foreign materials, and all oil and grease spots shall be removed. Such surfaces shall be carefully wiped and all cracks and corners scraped out. Exposed metal work shall be carefully brushed down with the steel brushes to remove rust and other spots and left smooth and clean.
- D. Color of finish painting noted shall be painted using Pratt and Lambert, Inc.'s "Effector" enamel, or approved equal. Two coats shall be applied with a light tint first coat and deep color for final coat. Colors shall be as follows:

<u>ITEM</u>	<u>COLOR</u>	<u>"P and L" PAINT NUMBER</u>
Pump Couplings and Fuel Gas Piping	Safety Yellow	Y361M (Daisy Yellow)
Fire Protection Equipment and Piping	Safety Red	R131R (Vibrant Red)

Note that the paint specified above is included for purposes of establishing a quality which shall be used on this project. The proposed paint shall be submitted, and alternatives will be considered using the submittal procedures specified in this document.

- E. Jacketing on insulation shall not be painted.
- F. No nameplates on equipment shall be painted, and suitable protection shall be afforded to the plates to prevent their being rendered illegible due to the painting operation.

- G. Scope of painting for Division 23 and 26 work in areas other than those defined as "exposed" is as follows:
1. All canvas finishes including those underfloor and in concealed spaces shall be painted with one sizing coat if not already sized, containing mildew resistant additive and Arabol adhesive prior to any other specified finish paint.
 2. All fuel piping (natural gas, LPG, etc.) and all fire protection piping shall be painted whether concealed or exposed, in all areas of the project without exception. Fuel piping shall be painted safety yellow, and fire protection piping shall be painted safety red. These "safety" colors shall be as defined by OSHA. Primer and first color coat may be omitted on piping above ceilings.
 3. If insulated, the piping shall be primed, only, prior to insulation, and the insulation jacketing shall be painted as specified for piping. The requirements of this paragraph are "primary" and have priority over any conflicting specification or instruction, should a conflict in the Construction Documents exist.
- H. The surfaces to be finish painted shall first be prepared as follows:
1. On canvas finishes pretreat as specified above. Insulated surfaces having vapor barrier jacket exposed to view shall first be painted with one (1) coat of sealer.
 2. Galvanized and black steel surfaces shall first be painted with one (1) coat of P&L galvanized metal primer. Primer may be eliminated on concealed fire and gas piping.
 3. Aluminum surfaces shall first be painted with one (1) coat of P&L zinc chromate primer. (See Section 1.51.5)
 4. Cast iron pipe shall first be primed with a "nonbleed" primer.
 5. The underside of all cast iron sinks not recessed in a cabinet are included as items to be painted in exposed areas.
- I. Where factory applied finishes are damaged in transit, storage or installation, or before final acceptance, they shall be restored to factory fresh condition by competent refinishers using the spray process.

PART 2 PRODUCTS

NOT USED

PART 3 EXECUTION

NOT USED

END OF SECTION

SECTION 23 05 29
SLEEVES, FLASHINGS, SUPPORTS AND ANCHORS

PART 1 GENERAL

1.00 The following sections are to be included as if written herein:

- A. Section 23 00 00 – Basic Mechanical Requirements
- B. Section 23 05 53 – Mechanical Identification

1.01 SECTION INCLUDES

- A. Pipe and equipment hangers and supports
- B. Sleeves and seals

1.02 RELATED SECTIONS

- A. Section 23 07 16 - Ductwork Insulation

1.03 REFERENCES

- A. ASME B31.9 - Building Services Piping
- B. ASTM F708 - Design and Installation of Rigid Pipe Hangers
- C. MSS SP69 - Pipe Hangers and Supports - Materials, Design and Manufacturer
- D. MSS SP89 - Pipe Hangers and Supports - Selection and Application
- E. MSS SP89 - Pipe Hangers and Supports - Fabrication and Installation Practices
- F. NFPA 13 - Installation of Sprinkler Systems
- G. UL 203 - Pipe Hanger Equipment for Fire Protection Service

1.04 SUBMITTALS

- A. Submit under provisions of Section 23 00 00.
- B. Shop Drawings: Indicate system layout with location and detail of trapeze hangers.
- C. Product Data: Provide manufacturers catalog data including load capacity.
- D. Design Data: Indicate load carrying capacity of trapeze, multiple pipe, and riser support hangers.
- E. Manufacturer's Installation Instructions: Indicate special procedures and assembly of components.

1.05 REGULATORY REQUIREMENTS

- A. Conform to applicable code for support of plumbing, hydronic, steam and steam condensate piping.
- B. Supports for Sprinkler Piping: Shall be in conformance with NFPA 13.
- C. Supports for Standpipes: Shall be in conformance with NFPA 14.

PART 2 PRODUCTS

2.01 HANGERS AND SUPPORTS

- A. Manufacturers:
 - 1. Grinnell.
 - 2. Kindorf
 - 3. B-Line
 - 4. Power Strut
 - 5. Anvil International
- B. Supports, hangers, anchors and guides shall be provided for all horizontal and vertical piping. Shop Drawings shall be provided, indicating locations and details of anchors, guides, expansion loops and joints, hangers, etc. The hanger design shall conform to the ASME Code for Pressure Piping.
- C. All auxiliary steel required for supports, anchors, guides, etc. shall be provided by the Mechanical Trades unless specifically indicated to be provided by others.
- D. The supports, hangers, anchors, and guides for the chilled water supply and return piping, steam piping, condensate return piping, etc. of the Campus Loop System routed above covered walk shall be provided as indicated on the Drawings.
- E. Contractor shall review all Drawings, including Structural Drawings, for details regarding pipe supports, anchors, hangers, and guides.
- F. All Supports shall be of type and arrangement to prevent excessive deflection, to avoid excessive bending stresses between supports, and to eliminate transmission of vibration.
- G. All rod sizes indicated in this Specification are minimum sizes only. This trade shall be responsible for structural integrity of all supports, anchors, guides, etc. All structural hanging materials shall have a minimum safety factor of 5 built in.
- H. Anchor points as indicated on Drawings or as required shall be located and constructed to permit the piping system to take up its expansion and contraction freely in opposite directions away from the anchored points.

- I. Guide points shall be located and constructed wherever required or indicated on Drawings and at each side of an expansion joint or loop, to permit free axial movement only.
- J. Supports, hangers, anchors, and guides shall be fastened to the structure only at such points where the structure is capable of restraining the forces in the piping system.
- K. Other special type of hangers may be employed where so specified or indicated on the Drawings, or where required by the particular conditions. In any case, all hangers must be acceptable to the owner.
- L. All electrical conduits shall be run parallel or perpendicular to adjacent building lines. Single conduits running horizontally shall be supported by "Caddy" or "Minerallac" type hangers from adequately sized rods (minimum 1/4") from the building structure. Where multiple conduits are run horizontally, they shall be supported on trapeze of "Unistrut" type channel suspended on rods or bolted to vertical building members. Conduit shall be secured to channel with galvanized "Unistrut" type conduit clamps or stainless steel "Unistrut" type "Uni-Clips." All hangers shall be fastened to the building structure in the same manner as specified above for pipe hangers. Spacing of hangers shall be adequate for the weight and rigidity of the conduits involved; in any case, no greater than 8' centers. Where feasible, conduits may be fastened to the concrete by one-hole straps thoroughly anchored to the concrete in an approved manner. Flexible conduit shall also be supported in an acceptable manner so as not to interfere with the maintenance of above-ceiling equipment, and to support it from touching the ceiling system. Conduit shall be located so as not to inhibit removal of ceiling tiles.
- M. Vertical conduits shall be supported as often as necessary for rigidity by clamps resting on adjacent beams or floor slabs, using a minimum of one support per floor.
- N. Perforated strap iron or wire will not, under any circumstances, be acceptable as hanger material.
- O. Where specifically noted on the drawings that one material is to be hung from the support of another material due to space restrictions, the hangers shall be sized to properly carry the weight of all items to be supported by such.
- P. Vibration Isolation: Resilient hangers shall be provided on all piping connected to rotating equipment (pumps, etc.). Piping or ductwork that may vibrate and create an audible noise shall also be isolated. Spring hangers or supports shall be provided where indicated on the Drawings and/or specified under Section 23 05 48.
- Q. Attachment:
 - 1. The load and spacing on each hanger and/or insert shall not exceed the safe allowable load for any component of the support system, including the concrete which holds the inserts. Reinforcement at inserts shall be provided as required to develop the strength required.
 - 2. Inserts shall be of a type which will not interfere with reinforcing as shown on the structural Drawings and which will not displace excessive amounts of structural concrete.
 - 3. All supports shall be designed and installed to avoid interference with other piping, hangers, ducts, electrical conduit, supports, building structures, equipment, etc. All piping shall be installed with due regard to expansion and contraction and the type of hanger method of support, location of support, etc. shall be governed in part by this Specification.

4. Hangers shall be attached to the structure as follows:

- a) **Poured In Place Concrete:** Where pipes and equipment are supported under poured in place concrete construction, each hanger rod shall be fitted with a nut at its upper end, which nut shall be set into an Underwriters Laboratories, Inc. listed universal concrete insert placed in the form work before concrete is poured. Where inserts are placed in the bottom faces of concrete joists which are too narrow to provide adequate strength of concrete to hold the insert properly or where a larger insert would require displacement of the bottom joist steel, the hanger rod shall be suspended from the center of a horizontal angle iron, channel iron, I-beam, etc. spanning across two adjacent joists. The horizontal support shall be bolted to nonadjustable concrete inserts of the "spot" type, of physical size small enough to avoid the bottom joist steel.
- b) **Steel Bar Joists:** Where pipes and loads are supported under bar joists, hanger rods may be run through the space between the bottom angles and secured with a washer and two nuts. Where larger lines are supported beneath bar joists, hanger rods shall be secured to angle irons of adequate size; each angle shall span across two or more joists as required to distribute the weight properly and shall be welded to the joists or otherwise permanently fixed thereto.
- c) **Steel Beams:** Where pipes and loads are supported under steel beams, approved type beam clamps shall be used.
- d) **Pre-Cast Tee Structural Concrete:** Hanger supports, anchors, etc. required for mechanical systems attached to the precast, double tee, structural concrete system are to be installed in accord with approved shop Drawings only. Holes required for hanger rods shall be core drilled in the "flange" of the double tee only; impact type tools are not allowed under any circumstances. Core drilling in the "stem" portions of the double tee is not allowed. Holes core drilled through the "flange" for hanger rods shall be no greater than 1/4" larger than the diameter of the hanger rod. Hanger rods shall be supported by means of bearing plates of size and shape acceptable to the Architect/Engineer, with welded double nuts on the hanger rod above the bearing plate. Cinch anchors, lead shields, expansion bolts, and studs driven by explosion charges are not allowed under any circumstances in the lower 15" of each stem and in the "shadow" of the stem on the top side of the "double tees."
- e) If it is necessary to install a method of fastening a hanger after the structure has been installed, then only clamps or drilled anchors shall be used.

Power-actuated fasteners (shooting) will not be acceptable under any circumstances.

Note: Under no circumstances will the use of plastic anchors or plastic expansion shields be permitted for any purpose whatsoever.

5. Power-actuated fasteners (shooting) will not be acceptable under any circumstances.

- R. **Finishes:** All hangers on piping including clevis hangers, rods, inserts, clamps, stanchions, and brackets, shall be dipped in Zinc Chromate Primer before installation. Rods may be galvanized

or cadmium plated after threading, in lieu of dipping zinc chromate. Universal concrete inserts shall be cadmium plated.

- S. Trapezes: Where multiple lines are run horizontally at the same elevation and grade, they may be supported on trapezes of Kindorf, Uni-Strut, Power Strut, or approved equal, channel-suspended on rods or pipes. Trapeze members including suspension rods shall each be properly sized for the number, size, and loaded weight of the lines they are to support.
- T. Miscellaneous: Provide any other special foundations, hangers and supports indicated on the Drawings, specified elsewhere herein; or required by conditions at the site. Hangers and supporting structures for suspended equipment shall be provided as required to support the load from the building structure in a manner acceptable to the Architect/Engineer.
- U. Miscellaneous: Provide any other special foundations, hangers and supports indicated on the Drawings, specified elsewhere herein; or required by conditions at the site. Hangers and supporting structures for suspended equipment shall be provided as required to support the load from the building structure in a manner acceptable to the Architect/Engineer.
- V. Ductwork supported from the floor: Ductwork supported from the floor shall be done by the same means as that supported from above, but shall include a neoprene vibration isolation spacer to restrict vibration transmission to the structure below.

2.03 ACCESSORIES

- A. Hanger Rods: Galvanized mild steel threaded both ends, galvanized threaded one end, or galvanized continuous threaded.
- B. Inserts: Malleable iron case of galvanized steel shell and expander plug for threaded connection with lateral adjustment, top slot for reinforcing rods, lugs for attaching to forms; size inserts to suit threaded hanger rods. Suitable concrete inserts for pipe and equipment hangers shall be set and properly located for all pipe and equipment to be suspended from concrete construction. If the inserts are later found not to be in the proper location for the placement of hangers, then drilled anchors shall be installed. Drilled anchors in concrete or masonry shall be submitted for the approval by the Owner.

2.04 WALL, FLOOR AND CEILING PLATES:

- A. Except as otherwise noted, provide C.P. (Chrome plated) brass floor and ceiling plates around all pipes, conduits, etc., passing exposed through walls, floors, or ceilings, in any spaces except underfloor and attic spaces. Plates shall be sized to fit snugly against the outside of the pipe or against the insulation on lines which are insulated and positively secured to such pipe or insulation. Plates will not be required for piping where pipe sleeves extend 3/4" above finished floor. All equipment rooms are classified as finished areas. Round and rectangular ducts shall have closure plates (NOT chrome plated) made to fit accurately at all floor, wall and ceiling penetrations. Floor penetrations in exposed (except in stair wells) areas shall be finished using 'bell' fitting to fit pipe or insulation and sleeve and shall be painted to match the pipe. Penetrations in stairwells shall have flat floor plate painted to match pipe.

2.05 SLEEVES

- A. General: All openings through all floors, walls, and roofs, etc., regardless of material for the passage of piping, ductwork, conduit, cable trays, etc., shall be sleeved. All penetrations must

pass through sleeves. Sleeves shall be set in new construction before concrete is poured, as cutting holes through any part of the concrete will not be permitted unless acceptable to the Architect/Engineer. If a penetration is cored into an existing vertical solid concrete, masonry or stone structure, then the installation of a sleeve will not be necessary.

1. Sleeve material for floors and exterior walls shall be Schedule 40 galvanized steel with welded water stop rings.
 2. Sleeves through interior walls to be galvanized sheetmetal with gauge as required by wall fire rating, 20 gauge minimum.
- B. The minimum clearance between horizontal penetrations including insulation where applicable, and sleeve shall be 1/4", except that the minimum clearance shall accommodate a Thunderline Link-seal closure where piping exits the building, or penetrates a wall below ground level. Contractor shall be responsible for the accurate location of penetrations in the slab for his pipe, duct, etc. All penetrations shall be of ample size to accommodate the pipe, duct, etc., plus any specified insulation. Void between sleeve and pipe in interior penetrations shall be filled with Nelson Flameseal Firestop or approved equal caulk or putty.
- C. Floor sleeves shall extend above the finished floor as detailed on the drawings, except that floor sleeves in stairwells shall be flush with the finished floor. Sleeves in walls shall be trimmed flush with wall surface. Refer to the details on the project drawings. Where the details differ from these specifications, the drawings take precedence.
- D. Sleeves for penetrations passing through walls or floors on or below grade shall be removed, if practical, and after the pipes have been installed, the void space around the pipe shall be caulked with a suitable material to effect a waterproof penetration. Note that the practicality of the removal of the sleeve shall be the decision of the Construction Inspector. The decision of the Inspector shall be final.
- E. Vermin proofing: The open space around all ductwork, piping, etc., passing through the ground floor and/or exterior walls shall be vermin proofed in a manner acceptable to the Architect/Engineer.
- F. Waterproofing: The annular space between a pipe and its sleeve in interior floors shall be filled with polyurethane foam rods 50 percent greater in diameter than the space as backing and fill material and made watertight with a permanent elastic polysulfide compound. Seal both surfaces of floor.
- G. Air Plenums: The space around piping, ductwork, etc., passing through air plenums shall be made airtight in a manner acceptable to the Architect/Engineer.
- H. Fireproofing: Seal all cable trays, pipe, conduit, duct, etc., penetrations through roof, fire rated walls and floors with a foam or sealant as described below, that will form a watertight, vermin tight barrier that is capable of containing smoke and fire up to 2000° F for two hours. Sealing of cable trays and conduits that extend through rated walls from ends of cable tray shall be done after conductors have been installed. For wet locations, the foam material shall be a silicone RTV foam or an approved equal. For dry locations, a premixed putty equal to Nelson Flameseal Firestop putty may be used.

PART 3 EXECUTION

3.01 INSTALLATION

- A. Install in accordance with manufacturer's instructions.

3.02 INSERTS

- A. Provide inserts for placement in concrete formwork.
- B. Provide inserts for suspending hangers from reinforced concrete slabs and sides of reinforced concrete beams.
- C. Provide hooked rod to concrete reinforcement section for inserts carrying pipe over 4 inches.
- D. Where concrete slabs form finished ceiling, locate inserts flush with slab surface.
- E. Where inserts are omitted, drill through concrete slab from below and provide through-bolt with recessed square steel plate and nut recessed into and grouted flush with slab.

3.03 SLEEVES

- A. Set sleeves in position in formwork. Provide reinforcing around sleeves.
- B. Size sleeves large enough to allow for movement due to expansion and contraction. Provide for continuous insulation wrapping.
- C. Extend sleeves through floors (except in stairwells) two inches above finished floor level. Sleeves through floors shall have welded waterstop rings. Sleeves shall be sealed watertight to floors and pipe.
- D. Where piping, ductwork or conduit penetrates floor, ceiling, or wall, close space between pipe or duct and adjacent work with fire stopping insulation and caulk airtight. Provide close fitting metal collar or escutcheon covers, as appropriate, at both sides of penetration.
- E. Install chrome plated steel or stainless steel escutcheons at finished surfaces.

3.04 LOW PRESSURE DUCT SUPPORT SCHEDULE:

- A. All horizontal ducts up to and including 40 inches in their greater dimension shall be supported by means of No. 18 U.S. gauge band iron hangers attached to the ducts by means of screws, rivets, or clamps and fastened to above inserts with toggle bolts, beam clamps or other approved means. Duct shall have at least one pair of supports 8' 0" on centers. Clamps shall be used to fasten hangers to reinforcing on sealed ducts.
- B. Horizontal ducts larger than 40 inches in their greatest dimension shall be supported by means of hanger rods bolted to angle iron trapeze hangers. Duct shall have at least one pair of supports 8' 0" on centers according to the following:

<u>Angle</u>	<u>Angle</u>	<u>Rod Diameter</u>
<u>Length</u>		

4' 0"	1-1/2" x 1-1/2" x 1/8"	1/4"
6' 0"	1-1/2" x 1-1/2" x 1/8"	1/4"
8' 0"	2" x 2" x 1/8"	5/16"
10' 0"	3" x 3" x 1/8"	3/8"

- C. Vertical ducts shall be supported where they pass through the floor lines with 1-1/2" x 1-1/2" x 1/4" angles for ducts up to 60". Above 60", the angles must be increased in strength and sized on an individual basis considering space requirements.

<u>Angle</u> <u>Length</u>	<u>Angle</u>	<u>Rod Dia.</u>
4'-0"	1-1/2" x 1-1/2" x 1/8"	1/4"
6'-0"	1-1/2" x 1-1/2" x 1/8"	1/4"
8'-0"	2" x 2" x 1/8"	5/16"
10'-0"	3" x 3" x 1/8"	3/8"

- D. Vertical ducts shall be supported where they pass through the floor lines with 1-1/2" x 1-1/2" x 1/4" angles for ducts up to 60". Above 60", the angles must be increased in strength and sized on an individual basis considering space requirements.

3.05 DUCT HANGERS - GENERAL NOTES (all pressures)

- A. Hanger straps on duct width of 60 inches and under shall lap under the duct a minimum of 1 inch and have minimum of one fastening screw on the bottom and two on the side.
- B. Hanger straps on duct widths over 60 inches shall be bolted to duct reinforcing with 3/8" bolts minimum.
- C. Use 3/8" minimum bolts for securing duct hanger to band straps.
- D. All round ducts shall be supported within 3 feet of all horizontal or vertical turns.

END OF SECTION

SECTION 23 05 53
MECHANICAL IDENTIFICATION

PART 1 GENERAL

1.00 The following sections are to be included as if written herein:

- A. Section 23 00 00 – Basic Mechanical Requirements
- B. Section 23 05 29 – Sleeves, Flashings, Supports and Anchors

1.01 SECTION INCLUDES

- A. Nameplates.
- B. Tags.
- C. Stencils.
- D. Pipe Markers.

1.02 PRODUCTS INSTALLED BUT NOT FURNISHED UNDER THIS SECTION

- A. NOT USED.

1.03 RELATED SECTIONS

- A. Section 23 00 00 - Basic Mechanical Requirements.

1.04 REFERENCES

- A. ASME A13.1 - Scheme for the Identification of Piping Systems.

1.05 SUBMITTALS

- A. Submit under provisions of Section 23 00 00.
- B. Submit list of wording, symbols, letter size, and color coding for mechanical identification.
- C. Submit valve chart and schedule, including valve tag number, location, function, and valve manufacturer's name and model number.
- D. Product Data: Provide manufacturers catalog literature for each product required.
- E. Samples: Submit two of each type of label, tag, etc., of the approximate size specified or implied in the specification.
- F. Manufacturer's Installation Instructions: Indicate special procedures, and installation.

1.06 PROJECT RECORD DOCUMENTS

- A. Submit under provisions of Section 23 00 00.
- B. Record actual locations of tagged valves.

PART 2 PRODUCTS

2.01 NAMEPLATES

A. Manufacturers:

1. Seaton.
2. Other acceptable manufacturers offering equivalent products.
 - a. Brady
 - b. Bunting
 - c. EMED

B. Description: Laminated three-layer plastic with engraved black letters on light contrasting background color.

2.02 TAGS

A. Manufacturers:

1. Seaton
2. Other acceptable manufacturers offering equivalent products.
 - a. W.H. Brady
 - b. Bunting

A. Metal Tags: Brass with stamped letters; tag size minimum 1-1/2 inch (40 mm) diameter with smooth edges.

B. Chart: Typewritten letter size list in anodized aluminum frame.

2.03 PIPE MARKERS

A. Manufacturers:

1. Seton
2. Other acceptable manufacturers offering equivalent products.
 - c. W.H. Brady
 - d. Bunting
 - e. EMED

B. Color: Conform to ASME A13.1.

C. Plastic Pipe Markers: Factory fabricated, flexible, semi-rigid plastic, preformed to fit around pipe or pipe covering; minimum information indicating flow direction arrow and identification of fluid being conveyed.

D. Plastic Tape Pipe Markers: Flexible, vinyl film tape with pressure sensitive adhesive backing and printed markings.

E. Underground Plastic Pipe Markers: Bright colored continuously printed plastic ribbon tape, minimum 6 inches (150 mm) wide by 4 mil (0.10 mm) thick, manufactured for direct burial service.

2.04 CEILING VINYL STICKERS

A. Manufacturers:

1. Seton
2. Other acceptable manufacturers offering equivalent products.
 - a. W.H. Brady
 - b. Bunting
 - c. EMED

B. Description: Vinyl stickers with arrow pointing to the ceiling tile needing to be removed for access to the equipment to be located on the grid.

C. Color code as follows:

1. Yellow - HVAC equipment
2. Red - Fire dampers/smoke dampers
3. Green - Plumbing valves
4. Blue - Heating/cooling valves

2.05 General: The Contractor shall make it possible for the personnel operating and maintaining the equipment and systems in this project to readily identify the various pieces of equipment, valves, piping, etc., by marking them. All items of equipment such as fans, pumps, etc., shall be clearly marked using engraved nameplates as hereinafter specified. The item of equipment shall indicate the same number as shown on the Drawings. For example, pumps will be identified as 3A, 3B, 3C, etc.; exhaust fans will be E-1, E-2, etc.; supply fans will be S-1, S-2, etc.

2.06 Mechanical: All items of mechanical equipment shall be identified by the attachment of engraved nameplates constructed from laminated phenolic plastic, at least 1/16" thick, 3-ply, with black surfaces and white core. Engraving shall be condensed Gothic, at least 1/2" high, appropriately spaced. Nomenclature on the label shall include the name of the item, its mark number, area, space, or equipment served, and other pertinent information. Equipment to be labeled shall include but not be limited to the following:

Zoning Boxes/Valves	Fire/Smoke dampers
Air Conditioning Control	Miscellaneous - similar
Panels and Switches	and/or related items

2.07 The Contractor shall prepare and install, in a suitable glazed frame, typewritten valve charts giving the number, location and function of each line valve installed under this Contract. Each valve shall be numbered on these charts in accordance with the system of which it is a part of its location. For example, valves in different systems would be designated as follows:

HPS-1-3 High Pressure Steam	1st Level - Valve No. 3
CHS-2-4 Chilled Water Supply	2nd Level - Valve No. 4

2.08 Specials: Refer to special requirements noted in the various sections hereinafter bound.

PART 3 EXECUTION

3.01 PREPARATION

- A. Degrease and clean surfaces to receive adhesive for identification materials.
- B. Prepare surfaces in accordance with Section 09 91 00 for stencil painting.

3.02 INSTALLATION

- A. Install plastic nameplates with corrosive-resistant mechanical fasteners, or adhesive. Apply with sufficient adhesive to ensure permanent adhesion and seal with clear lacquer.
- B. Install tags with corrosion resistant chain.
- C. Apply stencil painting in accordance with Section 09 91 00.
- D. Identify air handling units, pumps, heat transfer equipment, tanks, and water treatment devices with plastic nameplates. Small devices, such as in-line pumps, may be identified with tags.
- E. Identify control panels and major control components outside panels with plastic nameplates.
- F. Identify thermostats relating to terminal boxes or valves with nameplates.
- G. Identify air terminal units and radiator valves with numbered tags.
- H. Tag automatic controls, instruments, and relays. Key to control schematic.
- I. Provide ceiling tacks to locate valves, dampers or other concealed equipment above T-bar type panel ceilings. Locate in corner of panel closest to equipment.

END OF SECTION

SECTION 23 05 93
SYSTEM TESTING, ADJUSTING AND BALANCING

1.01 SUMMARY

- A. Testing, adjusting and balancing (TAB) of the air conditioning systems and related ancillary equipment will be performed by an impartial technically qualified TAB firm selected and employed by the Owner, separate and apart from the construction contract.
- B. The firm shall be capable of performing the services specified at the location of the facility described within the time specified, of preparing and submitting the detailed report of the actual field work performed, and following up the basic work as may be required.

1.02 QUALIFICATIONS

- A. The Firm shall be one which is organized to provide professional services of this specified type in the State of Texas and as a minimum shall have one (1) professional engineer licensed in the State of Texas, with current registration, to perform such professional services. This engineer shall be personally responsible for developing the job site data as required in the test procedures outlined in these Specifications.
- B. The Firm shall have operated a minimum of five (5) years under its current Firm name, and shall be in good standing with the State of Texas, Franchise Tax Board. The firm shall submit their full incorporated name, Charter Number and Taxpayer's I.D. Number for proper verification of the firm's status.
- C. The Firm shall be capable of providing a performance bond, by a bonding company licensed to do business in the State of Texas, if determined by the Owner that such a bond is required. The amount of the bond which may be required shall be equal to the cost of the proposal submitted, or in the case of more than one proposal, the sum of all such proposals and any awarded work in progress.
- D. All personnel used on the job site shall be either professional engineers or engineering technicians, who shall have been permanent, full time employees of the firm for a minimum of six (6) months prior to the start of work for this specific project.
- E. The TAB firm shall submit biographical data on the individual proposed to directly supervise the TAB work, as well as other personnel scheduled to perform the technical work under the contract. It shall also submit a background record of at least five years of specialized experience in the field of air hydronic system balancing, and shall possess properly calibrated instrumentation. The supervisory personnel for the TAB firm shall be registered engineers in the mechanical field and all of the employees used in the TAB firm shall be permanent, full-time employees of the firm.

1.03 REFERENCES

- A. AABC - National Standards for Testing and Balancing Heating, Ventilating, and Air Conditioning Systems, Fifth Edition 1989.
- B. ASHRAE - 1991 HVAC Applications Chapter 34: Testing, Adjusting and Balancing.
- C. ANSI/ASHRAE Standard 111-1988 - Practices for Measurement, Testing, Adjusting and Balancing of Buildings, Heating, Ventilation, Air Conditioning and Refrigeration Systems.

1.04 DOCUMENTS

- A. The TAB firm shall, as a requirement of the TAB contract, arrange with the Architect to compile one set of mechanical specifications, all pertinent change orders, and the following:
 - 1. One complete set of Drawings less the structural sheets.
 - 2. One set of mechanical floor plans of the conditioned spaces. These Drawings shall be ozalid type (blue or black on light background) reproductions to facilitate marking.
- B. Approved submittal data on equipment installed, and related changes as required to accomplish the test procedures outlined in Paragraphs 1.06 through 1.10 of this Specification will be available through the Construction Inspector.

1.05 RESPONSIBILITIES OF THE TAB FIRM

- A. The TAB personnel shall check, adjust, and balance the components of the air conditioning system which will result in optimal noise, temperature, and airflow conditions in the conditioned spaces of the building while the equipment of the system is operating economically. This is intended to be accomplished after the system components are installed and operating as provided for in the contract documents. It is the responsibility of the Mechanical Contractor to place the equipment into service. Variable air volume systems shall be balanced in accordance with AABC 1989 Standard, Fifth Edition.
- B. Liaison and Early Inspection:
 - 1. The TAB firm personnel on the job shall act as liaison between the Owner, Architect and Contractor. The following reviews (observations) and tests shall be performed by the TAB Agency:
 - a. During the design stage, before the documents are finalized, review the mechanical drawings and specifications for balanceability and provide commentary.
 - b. During construction, review all HVAC submittals such as control diagrams, air handling devices, etc., that pertain to commissioning work and balanceability.
 - c. Allow for a fixed number of trips to the project site, over and above those required for testing and balancing for inspection of installation of the mechanical piping systems, sheet metal work, temperature controls and other component parts of the heating, air conditioning and ventilating systems during the construction stage. These inspections shall be made prior to and/or at the above ceiling inspection. Commentary will be provided to the RCM of each observation.
 - d. Test one (1) 8" single duct terminal box for performance capability and leakage as described in Section 23 36 00.UT. The shipment of the box to the TAB Agency's lab will be at the manufacturer's cost and the test period will be for three (3) weeks from receipt of the box. Submittal data will not be approved until box testing passes. If the sample box is rejected for any reason the second test will be at the Contractor's cost and the time allowed will restart when the box is received at the TAB Agency.
 - e. Test one (1) 8" dual duct box for performance capability and leakage as described in Section 23 36 00.UT. The shipment of the box to the TAB

Agency's lab will be at the manufacturer's cost and the test period will be for three (3) weeks from receipt of the box. Submittal data will not be approved until box testing passes. If the sample box is rejected for any reason the second test will be at the Contractor's cost and the time allowed will restart when the box is received by the TAB agency.

- f. Test 10% of the single and dual duct boxes for casing and damper leakage when the shipment arrives at the project site. All testing (except for the initial boxes) shall be performed on site.

Boxes requiring re-testing will be charged to the Contractor at the unit price provided to the Owner.

- g. Test one (1) lab configuration including fume hood with air valve, general exhaust air with air valve and supply air with air valve for performance capability through a full range of inlet pressures. The tracking capability of the exhaust air versus the supply air will be with the submitted hood sash fully open and as the sash is closed in 2" increments until fully closed. Track the three (3) valve's response time in relation to sash movement and the lab differential.

2. During the balancing process, as abnormalities and malfunctions of equipment or components are discovered by the TAB personnel, the Construction Inspector shall be advised in writing so that the condition can be corrected by the Mechanical Contractor. The written document need not be formal, but must be understandable and legible. Data from malfunctioning equipment shall not be recorded in the final TAB report. The TAB firm shall not instruct or direct the Contractor in any of the work, but will make such reports as are necessary to the Owner.

1.06 FINAL AIR BALANCE

General: When systems are complete and ready for operation, the TAB Consultant will perform a final air balance for all air systems and record the results. The outside, supply, exhaust and return air volume for each air handling unit, supply fan and exhaust fan and the supply, exhaust or return air volume for each distribution device shall be adjusted to within $\pm 5\%$ of the value shown on the drawings. Air handling unit and fan volumes shall be adjusted by changing fan speed and adjusting volume dampers associated with the unit. Air distribution device volume shall be adjusted using the spin-in tap damper for flexible duct connected devices and the device OBD for duct connected devices. Air distribution devices shall be balanced with air patterns as specified. Duct volume dampers shall be adjusted to provide air volume to branch ducts where such dampers are shown. The general scope of balancing by the TAB Consultant will include, but is not limited to, the following:

1. Filters: Check air filters and filter media and balance only system with essentially clean filters and filter media. The Division 23 Contractor shall install new filters and filter media prior to the final air balance.
2. Blower Speed: Measure RPM at each fan or blower to design requirements. Where a speed adjustment is required, the Division 23 Contractor shall make any required changes.
3. Ampere Readings: Measure and record full load amperes for motors.
4. Static Pressure: Static pressure gains or losses shall be measured across each supply fan, cooling coil, heating coil, return air fan, air handling unit filter and exhaust fan. These readings shall be measured and recorded for this report at the furthest air device or terminal

unit from the air handler supplying that device. Static pressure readings shall also be provided for systems which do not perform as designed.

5. Equipment Air Flow: Adjust and record exhaust, return, outside and supply air CFM (s) and temperatures, as applicable, at each fan, blower and coil.
6. Coil Temperatures: Set controls for full cooling and for full heating loads. Read and record entering and leaving dry bulb and wet bulb temperatures (cooling only) at each cooling coil, heating coil and HVAC terminal unit. At the time of reading record water flow and entering and leaving water temperatures (In variable flow systems adjust the water flow to design for all the above readings).
7. Zone Air Flow: Adjust each zone of multizone units, each HVAC terminal unit and air handling unit for design CFM.
8. Outlet Air Flow: Adjust each exhaust inlet and supply diffuser, register and grille to within $\pm 5\%$ of design air CFM. Include all terminal points of air supply and all points of exhaust. Note: For Labs and Rooms that are negative exhaust air flow shall be set to design $+10\%$ and supply to design -5% . Positive areas will have opposite tolerances.
9. Pitot Tube Traverses: For use in future troubleshooting by maintenance personnel, all exhaust ducts, main supply ducts and return ducts shall have air velocity and volume measured and recorded by the traverse method. Locations of these traverse test stations shall be described on the sheet containing the data.
10. Maximum and minimum air flow on terminal boxes.

1.07 TESTING OF TEMPERATURE CONTROL SYSTEMS

- A. In the process of performing the TAB work, the TAB Agency shall:
 1. Work with the temperature control contractor to ensure the most effective total system operation within the design limitations, and to obtain mutual understanding of intended control performance.
 2. Verify that all control devices are properly connected.
 3. Verify that all dampers, valves and other controlled devices are operated by the intended controller.
 4. Verify that all dampers and valves are in the position indicated by the controller (open, closed or modulating).
 5. Verify the integrity of valves and dampers in terms of tightness of close-off and full-open positions. This includes dampers in multizone units, terminal boxes and fire/smoke dampers.
 6. Observe that all valves are properly installed in the piping system in relation to direction of flow and location.
 7. Observe the calibration of all controllers.
 8. Verify the proper application of all normally opened and normally closed valves.

9. Observe the locations of all thermostats and humidistats for potential erratic operation from outside influences such as sunlight, drafts or cold walls.
 10. Observe the locations of all sensors to determine whether their position will allow them to sense only the intended temperatures or pressures of the media. Control Contractor will relocate as deemed necessary by the TAB Agency.
 11. Verify that the sequence of operation for any control mode is in accordance with approved shop drawings and specifications. Verify that no simultaneous heating and cooling occurs.
 12. Verify that all controller setpoints meet the design intent.
 13. Check all dampers for free travel.
 14. Verify the operation of all interlock systems.
 15. Perform variable volume system verification to assure the system and its components track with changes from full flow to minimum flow.
- B. A systematic listing of the above testing and verification shall be included in the final TAB report.

1.08 REPORTS

- A. The activities described in this section shall culminate in a report to be provided in quadruplicate (4) individually bound to the RCM. Neatly type and arrange data. Include with the data the date tested, personnel present, weather conditions, nameplate record of test instrument and list all measurements taken after all corrections are made to the system. Record all failures and corrective action taken to remedy incorrect situation. The intent of the final report is to provide a reference of actual operating conditions for the Owner's operations personnel.
- B. All measurements and recorded readings (of air, water, electricity, etc.) that appear in the reports must have been made onsite by the permanently employed technicians or engineers of the firm.
- C. At the option of the Construction Inspector, all data sheets tabulated each day by TAB personnel shall be submitted for initial by the Construction Inspector. Those work sheets so initialed, or copies thereof, shall be presented as a supplement to the final TAB report.
- D. Submit reports on forms approved by the Owner & Engineer which will include the following information as a minimum:
 1. Title Page
 - a) Company Name
 - b) Company Address
 - c) Company telephone number
 - d) Project name
 - e) Project location
 - f) Project Manager
 - g) Project Engineer
 - h) Project Contractor
 - i) Project Identification Number

2. Instrument List
 - a) Instrument
 - b) Manufacturer
 - c) Model
 - d) Serial Number
 - e) Range
 - f) Calibration date
 - g) What test instrument was used for

3. Duct Traverse
 - a) System zone/branch
 - b) Duct size
 - c) Area
 - d) Design velocity
 - e) Design air flow
 - f) Test velocity
 - g) Test air flow
 - h) Duct static pressure
 - i) Air temperature
 - j) Air correction factor

4. Air Monitoring Station Data
 - a) Identification/location
 - b) System
 - c) Size
 - d) Area
 - e) Design velocity
 - f) Design air flow
 - g) Test velocity
 - h) Test air flow

5. Air Distribution Test Sheet
 - a) Air terminal number
 - b) Room number/location
 - c) Terminal type
 - d) Terminal size
 - e) Area factor
 - f) Design velocity
 - g) Design air flow
 - h) Test (final) velocity
 - i) Test (final) air flow

6. Control verification indicating date performed and any abnormalities identified.
 - a) Point Location/Description
 - b) EMS Readout (Setpoint and Actual)
 - c) Actual Readout

- d) Interlocks
- e) Safeties
 - 1) VSD Normal Operation
 - 2) VSD Bypass Operation
- f) Alarms
- g) Sequences of Operation

END OF SECTION

SECTION 23 05 93.A
SYSTEM PREPARATION FOR
TESTING, ADJUSTING AND BALANCING

1.01 SUMMARY

- A. Perform all work required to prepare the building HVAC systems for testing, adjusting and balancing indicated by the Contract Documents as follows:
 - 1. Responsibilities of project contractor.
 - 2. Preparation for balancing of air systems.
 - 3. Preparation for balancing of hydronic and steam systems.
- B. The scope of the TAB work as defined in Section 23 05 93 is indicated in order that the Contractor will be advised of the coordination, adjustment, and system modification which will be required under the project work in order to complete the Owner's requirements for final TAB. The TAB firm will not have a contractual relationship with any Contractor referred to herein, but will be responsible to the Construction Inspector and the Owner for the satisfactory execution of the TAB work. The Contractor in his original bid shall allow for the costs required to cover all work which may be required in the TAB phases as defined herein and as may be necessary for the completion of the TAB work as defined by the TAB firm.

1.02 RELATED SECTIONS

- A. Section 23 00 00 - Basic Mechanical Requirements.
- B. Section 23 31 00 - Ductwork.
- C. Section 23 33 00 - Ductwork Accessories.
- D. Section 23 37 00 - Air Outlets and Inlets.
- E. Section 23 09 23 - Direct Digital Control Systems.
- F. Section 23 05 93 - System Testing, Adjusting & Balancing.

1.03 SCOPE OF WORK

- A. Testing, adjusting, and balancing (TAB) of the air conditioning systems and related ancillary equipment will be performed by an impartial technically qualified TAB firm selected and employed directly by the Owner, separate and apart from the Construction Contract. However, the preparation for and corrections necessary for the Testing, Adjusting and Balancing of these systems, as described herein, are the responsibility of the Contractor.
- B. As a part of this project Construction Contract, the Contractor shall make any changes or replacements to the sheaves, belts, dampers, valves, etc. required for correct balance as advised by the TAB firm, at no additional cost to the Owner.
- C. The Contractor shall provide and coordinate the services of qualified, responsible Subcontractors, suppliers and personnel as required to correct, repair, and/or replace any and all deficient items or conditions found during the course of this project, including the testing, adjusting and balancing period.

- D. In order that all systems may be properly tested, balanced, and adjusted as required herein by these Specifications, the Contractor shall operate said systems at his expense for the length of time necessary to properly verify their completion and readiness for TAB. This length of time shall be subject to the approval of the Construction Inspector.
- E. Project Contract completion schedules shall allow for sufficient time to permit the completion of TAB services prior to Owner occupancy. The contractor shall allow adequate time for the testing and balancing activities of the owner provided services, during the construction period, and prior to Substantial Completion as defined in the Uniform General Conditions of this Construction Document.
- F. The Drawings and Specifications indicate valves, dampers and miscellaneous adjustment devices for the purpose of adjustment to obtain optimum operating conditions, and it will be the responsibility of the Contractor to install these devices in a manner that will leave them accessible and readily adjustable. Should any such device not be readily accessible, the Contractor shall provide access as requested by the TAB firm. Also, any malfunction encountered by TAB personnel and reported to the Contractor or the Construction Inspector shall be corrected by the Contractor immediately so that the balancing work can proceed with the minimum of delays.

1.04 RESPONSIBILITIES OF THE PROJECT CONTRACTOR:

A. The Contractor shall:

- 1. Have the building and air conditioning systems in complete operational readiness for TAB work to begin.
- 2. The contractor shall allow sufficient time for the TAB firm to perform his contracted work within the construction schedule. The contractor shall complete his work by systems or floors whichever is the most efficient for scheduling. After awarding of the contract and the contractor has developed a construction schedule, a TAB coordination meeting shall be held at the RCM's office with the TAB agency, the general contractor and his primary subcontractors (i.e. mechanical, electrical, building automation etc.) to develop a testing schedule for the project. The contractor shall submit copies of the proposed schedule two (2) weeks prior to this meeting to the RCM and TAB Agency.

The following are minimum time requirements:

TAB Agency will provide Engineer with tentative schedules for each area, floor and/or system to be included in this section.

Note: The hot water and chilled water systems must be 100% complete to balance. The air systems are pressure independent and can be balanced by floors, risers, systems, etc., but once the total system is complete the total flows and system tracking will require finalization. Lab certification will be performed when the building is 100% operational and balanced.

- 3. Promptly correct deficiencies of materials and workmanship identified as delaying completion of TAB work.
- 4. Be responsible for any added costs to the Owner resulting from his failure to have the building and air conditioning systems ready for TAB when scheduled, or from his failure to correct deficiencies promptly.

- B. Complete operational readiness of the building requires that construction status of the building shall permit the closing of doors, windows, ceilings installed, etc., to obtain simulated or projected operating conditions.
- C. Complete operational readiness of the air conditioning systems also requires that the following be accomplished:
 - 1. Air Distribution Systems:
 - a. Verify installation for conformity to design. All supply, return and exhaust ducts terminated and pressure tested for leakage as required by the Specification.
 - b. All volume, smoke and fire/smoke dampers are properly located and functional. Dampers serving requirements of minimum and maximum outside, return and relief air shall provide tight closure and full opening, smooth and free operation.
 - c. All supply, return, exhaust and transfer grilles, registers, diffusers and terminal devices installed.
 - d. Air handling systems, units and associated apparatus, such as heating and cooling coils, filter sections, access doors, etc., shall be blanked and/or sealed to eliminate excessive bypass or leakage of air.
 - e. All fans (supply, return and exhaust) operating and verified for freedom from vibration, proper fan rotation and belt tension; heater elements in motor starters to be of proper size and rating; record motor amperage and voltage on each phase at start-up and running, and verify they do not exceed nameplate ratings.
 - f. All single and/or double duct variable and constant volume terminal units ("mixing boxes") shall be installed and functional (i.e. controls functioning).
 - 2. Automatic Controls:
 - a. The Contractor shall schedule a meeting with the Engineer, Control Contractor, TAB firm and Owner's representative for a pre-submittal review to establish that their interpretations of the sequences of operation are correct.
 - b. Verify that all control components are installed in accordance with project requirements and are functional, including all electrical interlocks, dampers sequences, air and water resets, fire and freeze stats, high and low temperature thermostats, safeties, etc.
 - c. Verify that all controlling instruments are calibrated and set for design operating conditions with the exception of room thermostats or sensors, which shall be calibrated at the completion of TAB services with cooperation between the TAB firm and Control Contractor.
 - d. The Automatic Temperature Control Contractor and/or Energy Management System Contractor shall thoroughly check all controls, sensors, operators, sequences, etc. before notifying the TAB agency that the Automatic Temperature Controls and Energy Management System are

operational. The Automatic Temperature Contractor and/or Energy Management System Contractor shall provide technical support (technicians and necessary computers) to the TAB agency for a complete check of these systems.

3. Tabulated Data: The motor amperages, voltages shall be recorded showing "actual" and "nameplate" voltage and amperage and submitted and actual RPM. This applies to each piece of electrically driven air conditioning equipment in the system including supply and exhaust fans, fans of fractional horsepower, pumps, etc.

D. Notification of System Readiness:

1. After completion of the work in Paragraph 1.05 A through C above, the Contractor shall notify the Owner in writing, certifying that the work has been accomplished and that the building and the air conditioning systems are in operational readiness for testing, adjusting, and balancing. He shall include a copy of the tabulated data of Paragraph 1.04C.4 above.
2. The Owner will, in turn, notify the TAB firm of the readiness for balancing and forward copies of the Contractor's certification and the tabulated voltages and currents.
3. Should the TAB firm be notified as described above, and the TAB work commenced and the systems are found NOT to be in readiness or a dispute occurs as to the readiness of the systems, the Contractor shall request an inspection be made by duly appointed representative of the Owner, Architect, TAB firm and the Contractor. This inspection will establish to the satisfaction of the represented parties whether or not the systems meet the basic requirements for TAB services. Should the inspection reveal the TAB services notification to have been premature, all cost of the inspection and wasted work accomplished by the TAB firm shall be reimbursed to the appropriated parties by the Project Contractor.

1.05 RESPONSIBILITIES OF THE TAB FIRM

- A. Refer to Section 23 05 93 entitled "System Testing, Adjusting and Balancing".

END OF SECTION

SECTION 23 07 13
DUCTWORK INSULATION

PART 1 GENERAL

1.00 The following sections are to be included as if written herein:

- A. Section 23 00 00 – Basic Mechanical Requirements
- B. Section 23 05 29 – Sleeves, Flashings, Supports and Anchors
- C. Section 23 05 53 – Mechanical Identification

1.01 SECTION INCLUDES

- A. Ductwork insulation.
- B. Insulation jackets.

1.02 RELATED SECTIONS

- A. Section 23 00 00- General Mechanical Requirements.
- B. Section 23 05 53 - Mechanical Identification.
- C. Section 23 31 00 - Ductwork: Duct liner.
- D. Section 23 33 00 - Ductwork Accessories: Duct liner.

1.03 REFERENCES

- A. ASTM B209 - Aluminum and Aluminum-Alloy Sheet and Plate.
- B. ASTM C518 - Steady-State Heat Flux Measurements and Thermal Transmission Properties by Means of the Heat Flow Meter Apparatus.
- C. ASTM C553 - Mineral Fiber Blanket and Felt Insulation.
- D. ASTM C612 - Mineral Fiber Block and Board Thermal Insulation.
- E. ASTM E84 - Surface Burning Characteristics of Building Materials.
- F. ASTM E96 - Water Vapor Transmission of Materials.
- G. NFPA 255 - Surface Burning Characteristics of Building Materials.
- H. SMACNA - HVAC Duct Construction Standards - Metal and Flexible.
- I. UL 723 - Surface Burning Characteristics of Building Materials.

1.04 SUBMITTALS

- A. Submit under provisions of Section 23 00 00.

-
- B. Product Data: Provide product description, list of materials and thickness for each service, and locations.
 - C. Samples: Submit two samples of any representative size illustrating each insulation type.
 - D. Manufacturer's Installation Instructions: Indicate procedures which ensure acceptable workmanship and installation standards will be achieved.
- 1.05 QUALITY ASSURANCE
- A. Materials: Flame spread/smoke developed rating of 25/50 in accordance with NFPA 255.
- 1.06 QUALIFICATIONS
- A. Applicator: Company specializing in performing the work of this section with minimum three years experience.
- 1.07 DELIVERY, STORAGE, AND HANDLING
- A. Deliver, store, protect and handle products to site under provisions of Section 23 00 00.
 - B. Deliver materials to site in original factory packaging, labeled with manufacturer's density and thickness.
 - C. Store insulation in original wrapping and protect from weather and construction traffic.
 - D. Protect insulation against dirt, water, chemical, and mechanical damage.
- 1.08 ENVIRONMENTAL REQUIREMENTS
- A. Maintain ambient temperatures and conditions required by manufacturers of adhesives, mastics, and insulation cements.
 - B. Maintain temperature during and after installation for minimum period of 24 hours.
- PART 2 PRODUCTS
- 2.01 Insulation C:
- A. Blanket insulation similar in construction to Owens-Corning Fiberglass Series or Johns Manville Microlite, one pound per cubic foot minimum density with foil reinforced Kraft (FRK) vapor barrier facing. Insulation shall be wrapped on the ductwork in accordance to manufacturer's stretched-out criteria, with all circumferential joints butted and longitudinal joints overlapped a minimum of 2". Adhere insulation to metal with 4" strips of insulation bonding adhesive at 8" on center. On circumferential and longitudinal joints, the 2" flange of the facing shall be secured using 9/16" flare door staples applied 6" on center and taped with 4" wide fiberglass tape embedded in vapor barrier Emulsion and covered with vapor barrier emulsion until the tape is completely covered. All penetrations or punctures in facing shall also be taped. Vapor sealing of joints is not required on hot duct application where concealed.
- 2.02 Vapor Seal Emulsion – Where specified herein, joint and seam vapor sealant shall be water based materials equal to Foster 30-35, Hardcast "Flex-Grip" 550 (sprayed to 20 mil thickness), or Childers Chil-Perm WB CP-35.

-
- 2.03 All ductwork in the building and in the crawl spaces except exhaust and return ducts shall be insulated externally unless specifically excluded. Only sound attenuated return ducting may be insulated internally, if specifically designated as such.
- 2.04 Where ducts are lined internally, (see Drawings for Scope) no exterior insulation will be required, except where specifically stated otherwise. Where internal and external insulation join, they shall lap at least 24 inches.
- 2.05 Low pressure supply duct taps to ceiling diffusers shall be externally insulated including top of ceiling diffuser.
- 2.06 Flexible round ducts are specified in Section 23 31 00 as factory insulated.

PART 3 EXECUTION

3.01 EXAMINATION

- A. Verify that ductwork has been tested before applying insulation materials.
- B. Verify that surfaces are clean, foreign material removed, and dry.

3.02 INSTALLATION

- A. Install materials in accordance with manufacturer's instructions.
- B. Insulated ductwork conveying air below ambient temperature:
 - 1. Provide insulation with vapor barrier jackets.
 - 2. Finish with tape and vapor barrier jacket.
 - 3. Continue insulation through walls, sleeves, hangers, and other duct penetrations.
 - 4. Insulate entire system including fittings, joints, flanges, fire dampers, flexible connections, and expansion joints.
- C. Insulated ductwork conveying air above ambient temperature:
 - 1. Provide with or without standard vapor barrier jacket.
 - 2. Insulate fittings and joints. Where service access is required, bevel and seal ends of insulation.
- D. Duct and Plenum Liner Application:
 - 1. Adhere insulation with adhesive for 100 percent coverage.
 - 2. Secure insulation with mechanical liner fasteners. Refer to SMACNA Standards for spacing.
 - 3. Seal and smooth joints.

-
4. Seal liner surface penetrations with adhesive.
5. Duct dimensions indicated are net inside dimensions required for air flow. Increase duct size to allow for insulation thickness.
- 3.03 All piping, equipment, ductwork, all plenums including metal and masonry construction, fans, etc., shall be insulated as indicated on the Drawings, as specified herein, and as required for a complete system. In each case, the insulation shall be equal to that specified and materials applied and finished as described in these Specifications.
- 3.04 All insulation shall be applied by mechanics skilled in this particular work and regularly engaged in such occupation. All insulation shall be applied in strict accordance with these Specifications and with factory printed recommendations on items not herein mentioned. Unsightly, inadequate, or sloppy work will not be acceptable, and all such work shall be removed and replaced as many times as necessary to achieve an acceptable installation.
- 3.05 All insulation, jacket, adhesives, mastics, sealers, etc., utilized in the fabrication of these systems shall meet NFPA for fire resistant ratings (maximum of 25 flame spread and 50 smoke developed ratings) and shall be approved by the insulation manufacturer for guaranteed performances when incorporated into their insulation system, unless a specific product is specified for a specific application, and is stated as an exception to this requirement. Certificates to this effect shall be submitted along with Contractor's submittal data for this section of the Specifications. No material may be used that, when tested by the ASTM E84-89 test method, is found to melt, drip or delaminate to such a degree that the continuity of the flame front is destroyed, thereby resulting in an artificially low flame spread rating.
- 3.06 All surfaces to be insulated shall be clean and dry before applying the insulation. Where an insulation covering is applied, it shall lap the adjoining section of insulation by at least three inches (3"). Where insulation terminates, it shall be neatly beveled and finished. No insulation shall be applied until the pipe, duct, etc., have been pressure tested and found tight. Flexible connections on duct shall not be covered. All materials used shall be fire retardant or nonflammable..
- 3.07 Where vapor barriers are required, the vapor barrier shall be on the outside. Extreme care shall be taken that the vapor barrier is unbroken. Joints, etc., shall all be sealed. Where insulation with a vapor barrier terminates, it shall be sealed off with the vapor barrier being continuous to the surface being insulated. Ends shall not be left raw.
- 3.08 Extreme care shall be taken in covering high and medium pressure (high and medium pressure ductwork shall be all ductwork between the fan discharge and all mixing boxes) ductwork to insure the duct is not pierced with sheet metal screws or other fasteners. All high and medium pressure ducts in these specifications are classified as high velocity ductwork.
- 3.09 Where canvas finish is specified, use Arabol lagging adhesive to prevent mildew in securing canvas. Do not use wheat paste. In addition, cover all canvas insulation with a fire retardant coating.
- 3.10 For purpose of definition in this Specification: "concealed" areas are those areas which cannot be seen by the building occupants, and "exposed" areas are all areas which are exposed to view by the building occupants, including under counter and inside cabinet areas, plus all mechanical rooms.
- 3.11 The handling and installation of all insulation materials shall be performed in strict accordance with the manufacturer's recommendations.

3.12 TOLERANCE

- A. Substituted insulation materials shall provide thermal resistance within 10 percent at normal conditions, as materials indicated.

3.13 DUCT INSULATION SCHEDULE:

<u>Duct Type</u>	<u>Insulation Type</u>
Low Pressure Supply Duct (including tops of diffusers)	2" Insulation C

END OF SECTION

SECTION 23 09 23
DIRECT DIGITAL CONTROL SYSTEMS
BACKBONE SYSTEMS HAVE BEEN INSTALLED IN THE SHELL & CORE
INFORMATION ON PREVIOUSLY INSTALLED EQUIPMENT IS FOR INFORMATION ONLY.
ADDITIONAL EQUIPMENT AS NOTED WILL BE REQUIRED AS NOTED ON THE DRAWINGS.

PART 1 GENERAL

1.00 THE FOLLOWING SECTIONS ARE TO BE INCLUDED AS IF WRITTEN HEREIN:

- A. Section 23 00 00 – Basic Mechanical Requirements
- B. Section 23 05 29 – Sleeves, Flashings, Supports and Anchors
- C. Section 23 05 53 – Mechanical Identification

1.01 SECTION INCLUDES

- A. Control equipment.
- B. Software.

1.02 PRODUCTS FURNISHED BUT NOT INSTALLED UNDER THIS SECTION

- A. Section 23 33 00 - Ductwork Accessories: Installation of automatic dampers, smoke detectors. Connection of damper end switches.

1.04 RELATED SECTIONS

- A. Section 26 05 00 - Equipment Wiring Systems.

1.05 REFERENCES

- A. ASHRAE 85 - Automatic Control Terminology for Heating, Ventilating, Air Conditioning.
- B. ASME MC85.1 - Terminology for Automatic Control.
- C. NEMA EMC1 - Energy Management Systems Definitions.

1.06 DEFINITIONS

- A. Ensure terminology used in submittals conforms to ASHRAE 85.

1.07 SYSTEM DESCRIPTION

- A. The system is an existing JCI system. .
- B. Automatic temperature control field monitoring and control system using field programmable micro-processor based units with communications to the existing Metasys Campus Building Management System.
- C. Central and remote hardware, software, and interconnecting wire and conduit.
- D. Terminal unit controls for variable air volume terminals, radiation, reheat coils, unit heaters, fan coils, pneumatic or electric unless indicated otherwise.

- E. The DDC systems shall be installed by JCI under a direct contract with the General Contractor. JCI shall provide "open-book" pricing to the General Contractor and UTHSC-H per the existing UTHSC-H/JCI agreement.**
- F. All sensors that are installed in insulated pipe or ductwork shall be installed with standoffs to allow proper insulation of all materials and continuation of vapor barriers.**

1.08 SUBMITTALS

- A. Submit under provisions of Section 01 33 00.
- B. Shop Drawings:
 - 1. Trunk cable schematic showing programmable control unit locations, and trunk data conductors.
 - 2. List of connected data points, including connected control unit and input device.
 - 3. System graphics indicating monitored systems, data (connected and calculated) point addresses, and operator notations.
 - 4. System configuration with peripheral devices, batteries, power supplies, diagrams, modems, and interconnections.
 - 5. Descriptive data and sequence of operation of operating, user, and application software.
 - 6. Provide one additional submittal above that which is asked for in Division 1 to be distributed by UTHSC-H to the IT department for verification.
- C. Product Data: Provide data for each system component and software module.
- D. Manufacturer's Installation Instructions: Include for all manufactured components.

1.09 PROJECT RECORD DOCUMENTS

- A. Submit under provisions of Section 01 77 00.
- B. Accurately record actual location of control components, including panels, thermostats, and sensors.
- C. Revise shop drawings to reflect actual installation and operating sequences.
- D. Include data specified in "Submittals" in final "Record Documents" form.

1.10 OPERATION AND MAINTENANCE DATA

- A. Submit under provisions of Section 01 77 00.
- B. Include interconnection wiring diagrams complete field installed system with identified and numbered, system components and devices.
- C. Include keyboard illustrations and step-by-step procedures indexed for each operator function.

-
- D. Include graphics of the controlled system as they appear on the system graphics with variable, adjustable and fixed points with showing identified and numbered systems, system components and devices.
 - E. Include inspection period, cleaning methods, cleaning materials recommended, and calibration tolerances.
- 1.11 QUALIFICATIONS
- A. Manufacturer: JCI controls.
 - B. Installer: JCI controls
 - C. Design system software under direct supervision of a Professional Engineer experienced in design of this work and licensed in the State of Texas.
- 1.12 PRE-INSTALLATION CONFERENCE
- A. Convene a conference one week prior to commencing work of this Section, under provisions of Section 01200.
 - B. Require attendance of parties directly affecting the work of this Section.
- 1.13 COORDINATION
- A. Coordinate work under provisions of Section 00 10 05.
 - B. Ensure installation of components is complementary to installation of similar components in other systems.
 - C. Coordinate installation of system components with installation of mechanical systems equipment such as air handling units and air terminal units.
 - D. Coordinate the startup and control sequence verification with the test and balance agent.
 - E. Ensure system is completed and commissioned.
- 1.14 WARRANTY
- A. Provide five year warranty under provisions of Section 01 78 36.
 - B. Warranty: Include coverage for field programmable micro-processor based units.
- 1.15 PROTECTION OF SOFTWARE RIGHTS
- A. Prior to delivery of software, the Owner and the party providing the software will enter into a software license agreement with provisions for the following:
 - 1. Limiting use of software to equipment provided under these specifications.
 - 2. Limiting copying.
 - 3. Preserving confidentiality.
 - 4. Prohibiting transfer to a third party.

PART 2 PRODUCTS

2.00 MANUFACTURERS OF CONTROLS

A JCI

2.01 GENERAL DESCRIPTION

A The Building Management System (BMS) shall use an open architecture and fully support a multi-vendor environment. To accomplish this effectively, the BMS shall support open communication protocol standards and integrate a wide variety of third-party devices and applications. The system shall be designed for use on the Internet, or intranets using off the shelf, industry standard technology compatible with other owner provided networks. Prior to submittal update equipment to the latest technology and coordinate with the Engineer.

B The Building Management System shall consist of the following:

- 1 Standalone Network Automation Engine(s)
- 2 Field Equipment Controller(s)
- 3 Input/Output Module(s)
- 4 Local Display Device(s)
- 5 Portable Operator's Terminal(s)
- 6 Distributed User Interface(s)
- 7 Network processing, data storage and communications equipment
- 8 Other components required for a complete and working BMS

C The system shall be modular in nature, and shall permit expansion of both capacity and functionality through the addition of sensors, actuators, controllers and operator devices, while re-using existing controls equipment.

D System architectural design shall eliminate dependence upon any single device for alarm reporting and control execution.

- 1 The failure of any single component or network connection shall not interrupt the execution of control strategies at other operational devices.
- 2 The System shall maintain all settings and overrides through a system reboot.
- 3 System architectural design shall eliminate dependence upon any single device for alarm reporting and control execution.

E Conduit and boxes shall be installed and supported per 23 05 29. Controls conduit shall be 3/4" EMT that is blue in color. The boxes shall be type 1900 and where the mixing box is located inside of the office area, the conduit shall be stubbed on from the junction box into the office space as close to the box as possible above the ceiling.

2.02 FIELD DEVICES

A Thermostats

- 1 Electric room thermostats of the heavy-duty type shall be provided for unit heaters, cabinet unit heaters, and ventilation fans, where required. All these items shall be provided with concealed adjustment. Finish of covers for all room-type instruments

shall match and, unless otherwise indicated or specified, covers shall be manufacturer's standard finish.

- 2 Actuation / Control Type
- 3 Primary Equipment
 - (a) Controls shall be provided by equipment manufacturer as specified herein.
 - (b) All damper and valve actuation shall be electric.
- 4 Air Handling Equipment
 - (a) All air handlers shall be controlled with a HVAC-DDC Controller
 - (b) All damper and valve actuation shall be electric.

PART 3 EXECUTION

END OF SECTION

SECTION 23 31 00
DUCTWORK

PART 1 GENERAL

1.00 The following sections are to be included as if written herein:

- A. Section 23 00 00 – Basic Mechanical Requirements
- B. Section 23 05 29 – Sleeves, Flashings, Supports and Anchors
- C. Section 23 05 53 – Mechanical Identification

1.01 WORK INCLUDED

- A. Low pressure ducts.

1.02 RELATED WORK

- A. Section 09 91 00 - Painting: Weld priming, weather resistant, paint or coating.
- B. Section 23 00 00 - Basic Mechanical Requirements.
- C. Section 23 05 29 - Sleeves, Flashings, Supports and Anchors.
- E. Section 23 07 13 - Duct Insulation.
- F. Section 23 33 00 - Ductwork Accessories.
- G. Section 23 05 93.A - Testing, Adjusting and Balancing.

1.03 REFERENCES

- A. ASHRAE - Handbook of Fundamentals; Duct Design.
- B. ASHRAE - Handbook of Equipment; Duct Construction.
- C. ASTM A 90 - Weight of Coating on Zinc-Coated (Galvanized) Iron or Steel Articles.
- D. ASTM A 167 - Stainless and Heat-Resisting Chromium-Nickel Steel Plate, Sheet, and Strip.
- E. ASTM A 525 - General Requirements for Steel Sheet, Zinc-Coated (Galvanized) by the Hot-Dip Process.
- F. ASTM A 527 - Steel Sheet, Zinc-Coated (Galvanized) by Hot-Dip Process, Lock Forming Quality.
- G. ASTM B209 - Aluminum and Aluminum Alloy Sheet and Plate.
- H. ASTM C 14 - Concrete Sewer, Storm Drain, and Culvert Pipe.
- I. ASTM C 443 - Joints for Circular Concrete Sewer and Culvert Pipe, Using Rubber Gaskets.
- J. NFPA 90A - Installation of Air Conditioning and Ventilating Systems.

-
- K. NFPA 90B - Installation of Warm Air Heating and Air Conditioning Systems.
 - L. NFPA 96 - Installation of Equipment for the Removal of Smoke and Grease-Laden Vapors from Commercial Cooling Equipment.
 - M. SMACNA - Low Pressure Duct Construction Standards.
 - N. SMACNA - High Pressure Duct Construction Standards.
 - O. UL 181 - Factory-Made Air Ducts and Connectors.

1.04 REFERENCES

- A. Fundamentals Handbook, American Society of Heating, Refrigerating, and Air Conditioning Engineers (ASHRAE).
- B. Equipment Handbook, ASHRAE.
- C. HVAC Duct Construction Standards, Sheet Metal and Air Conditioning Contractors National Association (SMACNA).
- D. HVAC Duct System Design, SMACNA.
- E. Round Industrial Duct Construction Standards, SMACNA.
- F. Engineering Design Manual for Air Handling Systems, United McGill Corporation (UMC).
- G. Assembly and Installation of Spiral Duct and Fittings, UMC.
- H. Engineering Report No. 132 (Spacing of Duct Hangers), UMC.

1.05 DEFINITIONS

- A. Duct Sizes: Inside clear dimensions. For lined ducts, maintain sizes inside lining.
- B. Low Pressure: 2 inch WG positive or negative static pressure and velocities less than 1,500 fpm.
- C. Medium Pressure: 6 inch WG positive static pressure and velocities greater than 1,500 fpm.

1.06 REGULATORY REQUIREMENTS

- A. Construct ductwork to NFPA 90A, NFPA 90B and NFPA 96 standards.

1.07 SUBMITTALS

- A. Shop Drawings shall be submitted on all items of sheet metal work specified herein. Shop Drawings of ductwork at air units shall be submitted at a minimum scale of 3/8" equal to one foot.
- B. Shop Drawings shall be submitted on all other ductwork per Section 23 00 00. Shop Drawings shall indicate location of all supply, return, exhaust and light fixtures from the approved reflected ceiling plans.
- C. Submit shop drawings and product data under provisions of Section 23 00 00.

-
- D. Submit samples under provisions of Section 23 00 00.

1.08 DELIVERY, STORAGE, AND HANDLING

- A. Deliver products to site under provisions of Section 23 00 00.
- B. Store and protect products under provisions of Section 23 00 00.

PART 2 PRODUCTS

2.01 DUCTWORK GENERAL:

- A. All ductwork indicated on the Drawings, specified or required for the air conditioning and ventilating systems shall be of materials as hereinafter specified unless indicated otherwise. All air distribution ductwork shall be fabricated, erected, supported, etc., in accordance with all applicable standards of SMACNA Duct Manuals where such standards do not conflict with NFPA 90A and where class of construction equals or exceeds that noted herein. All exhaust ductwork including toilet room exhausts shall be constructed and leak tested as specified for medium pressure supply ducts at negative pressure.
- B. All ductwork shown on the Drawings, specified or required for the heating, ventilating and air conditioning systems shall be constructed and erected in a first class workmanlike manner. The work shall be guaranteed for a period of one (1) year from and after the date of acceptance of the job against noise, chatter, whistling, vibration, and free from pulsation under all conditions of operation. After the system is in operation, should these defects occur, they shall be corrected as directed by the Architect.
- C. All duct sizes shown on the Drawings are air stream sizes. Allowance shall be made for internal lining where required, to provide the required cross sectional area.
- D. All holes in ducts for damper rods and other necessary devices shall be either drilled or machine punched (not pin punched), and shall not be any larger than necessary. All duct openings shall be provided with sheet metal caps if the openings are to be left unconnected for any length of time.
- E. Except for special ducts specified elsewhere herein, all sheet metal used on the project shall be constructed from prime galvanized steel sheets and/or coils up to 60" in width. Each sheet shall be stenciled with manufacturer's name and gauge. Coils of sheet steel shall be stenciled throughout on ten foot (10') centers with manufacturer's name and must be visible after duct is installed. Sheet metal must conform to SMACNA sheet metal tolerances as outlined in SMACNA's "HVAC Duct Construction Standards."
- F. Where ducts, exposed to view (including equipment rooms), pass through walls, floors or ceilings, furnish and install sheet metal collars around the duct.

2.02 DUCTWORK LOW PRESSURE:

- A. The scope of low pressure ductwork is defined as all ductwork downstream of terminal units. Construction of all low pressure duct shall be in accordance with Low Velocity Duct Construction Standards as published by Sheet Metal and Air Conditioning Contractors National Association (SMACNA) and shall be sealed and tested at 3" static with the same test procedures as medium pressure ductwork.
- B. Spiral wound round duct shall be as manufactured by United McGill Sheet Metal Company or approved equal.

- C. The metal gauges listed in the 1985 SMACNA HVAC Duct Construction Standards for Metal and Flexible Duct are the minimum which shall be used for this project if not otherwise specified herein. It shall be noted that the Contractor is responsible that the metal gauge selected is heavy enough to withstand the physical abuse of the installation.
- D. Elbows shall be radius type and have a centerline radius of 1-1/2 times the duct diameter or width. Elbows in round ducts may be smooth radius as described above or 5-piece 90 degree elbows and 3-piece 45 degree elbows. Joints in round ducts shall be slip type with a minimum of three sheet metal screws. Joints in sectional elbows shall be sealed as specified for duct sealing.
- E. SEALANT: All ductwork (except welded exhaust duct) shall be sealed with either "MP" (Multi-Purpose), Hardcast "Iron-grip 601", Hardcast "Flex-Grip 550 (spray applied to 20 mil thickness), or "United Duct Seal" (United McGill Corp.) water base, latex or acrylic type sealant. Note that, except as noted, oil or solvent based sealants are specifically prohibited for use on this project. For exterior applications, "Uni-Weather" (United McGill Corp.) neoprene based sealant shall be used. No other sealants may be used. All seams and joints in shop and field fabricated ductwork shall be sealed by applying one layer of sealant, then immediately spanning the joint with a single layer of 3" wide open weave fiberglass tape. Sufficient additional sealant shall then be applied to completely imbed the cloth. All sealants shall be UL rated at no more than flame spread of 5 and smoke developed of 0. At contractor's option Hardcast 1602 sealant tape may be used in lap joints and flat seams.

2.03 DUCTWORK MEDIUM PRESSURE:

- A. The scope of medium pressure ductwork is defined as all ductwork downstream of all air handlers, up to and including terminal units, plus all exhaust air ductwork. Construction of all ducts shall be in accordance with High Velocity Construction Standards as published by SMACNA. All round and rectangular duct construction, duct fittings, dampers, etc., are covered in this manual and it is to be adhered to.
 - 1. Spiral wound round duct shall be as manufactured by United McGill Sheet Metal Company or approved equal.
 - 2. The metal gauges are listed herein for round duct and for rectangular duct.
- B. All ductwork (except welded exhaust duct) shall be sealed with either "MP" (Multi-Purpose), Hardcast "Iron-grip 601", or "United Duct Seal" (United McGill Corp.) water base, latex or acrylic type sealant. Note that, except as noted, oil or solvent based sealants are specifically prohibited for use on this project. For exterior applications, "Uni-Weather" (United McGill Corp.) solvent based sealant shall be used. No other sealants may be used. All seams and joints in shop and field fabricated ductwork shall be sealed by applying one layer of sealant, then immediately spanning the joint with a single layer of 3" wide open weave fiberglass tape. Sufficient additional sealant shall then be applied to completely imbed the cloth. At contractor's option Hardcast 1602 sealant tape may be used in lap joints and flat seams.
- C. Oval ducts shall be spiral flat oval or welded flat oval equal to those of United McGill Sheet Metal Company with gauges and reinforcing as recommended by the manufacturer for medium pressure or the ducts may be Shop fabricated of completely welded construction of the following gauge:

Major Axis 12 to 20	No. 24 gauge
Major Axis 20 to 30	No. 22 gauge
Major Axis 30 to 46	No. 20 gauge

Major Axis 46 to 50 No. 18 gauge

Major Axis 50 and Up No. 16 gauge

- D. Oval fittings shall be equal to those of United McGill Sheet Metal Company with requirements, sealing, etc., similar to that specified for round medium pressure work.
- E. Oval duct reinforcing methods shall be submitted as Shop Drawings for approval. Reinforcing galvanized angles shall be of sizes specified for same size rectangular ducts. Galvanized angles shall be used where standing seams are specified for rectangular ducts. Attaching methods shall be shown on Shop Drawings and submitted for approval.
- F. Testing of Medium Pressure Ductwork: (Includes from fan discharge through to the discharge of terminal units.)
1. All medium pressure ducts shall be pressure tested according to SMACNA Chapter 10 test procedures. Design pressure for testing ductwork shall be six inches (6") of water. Total allowable leakage shall not exceed 1% of the total system design air flow rate. When partial sections of the duct system are tested, the summation of the leakage for all Sections shall not exceed the total allowable leakage.
1. The entire system of medium pressure ductwork shall be tested, excluding the VAV/Constant Volume Terminal Units (i.e. The ductwork shall be capped immediately prior to the Terminal Units, and tested as described above). After testing has proven that the ductwork is installed and performs as specified, the terminal units shall be connected to the ductwork and the connections sealed with extra care. The contractor shall inform the project inspector when the joints may be visually inspected for voids, splits, or improper sealing of the joints. If any leakage in the terminal unit connections/joints after the systems have been put into service, the leaks shall be repaired by: 1) complete removal of the sealing materials, 2) thorough cleaning of the joint surfaces, and 3) installation of multiple layers of sealing materials.
- G. All exhaust ductwork, including toilet room exhausts, shall be constructed as for medium pressure ducts and shall be tested for leaks in the same manner as for medium pressure supply ducts. Testing may exclude any zoning valves as well. The duct shall be capped upstream and downstream of the valves and tested on both sides. Testing can be done before spin-ins are installed if there is no sheetmetal ductwork after the spin-in, or an additional 1 cfm can be added to the total allowable cfm leakage for each dampered spin-in. The total leakage for both upstream and downstream shall be no more than 1% of the total design cfm.
- H. DUCTMATE or Ward coupling system may be used on rectangular ductwork. Contractor may (where space permits) use rectangular ductwork with DUCTMATE or Ward system in lieu of oval ductwork. Joints shall be assembled with pre-formed isobutylene gasket (min. 3/16" thick x 5/8" wide), equal to Ductmate 440 tape or McGill "Uni-Butyl" tape. After assembly, entire joint shall be coated with 20 mil thickness of Hardcast "Flex-Grip" 550. No other flange-type duct joining systems may be used. Duct gauges shall be as specified herein.
- I. Rectangular 90 degree elbows shall be constructed with single thickness turning vanes. Radius type rectangular elbows shall have a centerline radius of 1-1/2 times the duct diameter or width. Contractor shall have the option to substitute short radius vaned elbows, but shall request the substitution at the time of submittal of Shop Drawings, and shall request the substitution as required in Section 23 0000. Elbows in round or oval ducts may be smooth long radius as described above or 5-piece 90 degree elbows and 3-piece 45 degree elbows. Joints in round ducts shall be slip type with a minimum of three sheet metal screws. Joints in sectional elbows shall be sealed as specified for duct sealing.

2.04 ELBOWS:

- A. Where rectangular elbows are shown, or are required for good air flow, contractor shall provide and install turning vanes. Job fabricated turning vanes, if used, shall be fabricated of the same gauge and type of material as the duct in which they are installed. Vanes must be fabricated for same angle as duct offset. Radius elbows shall have a centerline radius of not less than one and one-half (1-1/2) times the duct width. Submit Shop Drawings on factory fabricated and job fabricated turning vanes. Provide turning vanes in all rectangular radius elbows and offsets.
- B. All turning vanes shall be anchored to the cheeks of the elbow in such a way that the cheeks will not breathe at the surfaces where the vanes touch the cheeks. In most cases, this will necessitate the installation of an angle iron support on the outside of the cheek parallel to the line of the turning vanes.
- C. Where turning vanes are to be provided and installed as required above. Only single thickness turning vanes shall be used.

2.05 FLEXIBLE DUCTS:

- A. Medium Pressure Insulated Flexible Duct may be used where shown on the drawings. Duct shall be made with factory preinsulated duct composed of dead soft, spiral wound, triple locked corrugated aluminum core covered with a minimum of 1-1/2" thick, 3/4 lb. density fiberglass blanket sheathed in a vapor barrier of fiberglass reinforced aluminum foil and mylar laminate. The insulation shall have a minimum "K" factor of 0.29 at 60 degrees F. mean and a vapor barrier permeability rating of 0.05 per ASTM method E96-66, Procedure A. The C factor shall be 0.24 to meet HUD requirements. The duct shall be rated for a positive working pressure of 10" w.g. and a temperature of up to 250 degrees F. The duct must comply with the latest NFPA Bulletin 90A and be listed and labeled by Underwriter's Laboratories, Inc., as Class I Air Duct, Standard 181, and meet GSA, FHA and other U. S. Government standards; flame spread, not over 15; smoke developed, not over 10. Flexible ducts shall be not more than 24" in length, shall be installed in straight runs only, and shall be Flexmaster Type TL-M or approved equal.
 - 1. The terminal ends of the duct core shall be secured by compression coupling or stainless steel worm gear type clamp equal to Ideal Series 56 Snaplock. The fittings on air mixing devices and on sheet metal duct shall be coated with the sealant specified for low pressure ductwork, then flexible duct core slipped over duct and coupling or clamp tightened, then connection sealed with more sealant. Insulation of flexible duct shall be slipped over connection to point where insulation abuts mixing box or insulation on duct. These insulation connections shall be sealed by imbedding fiberglass tape in the sealant specified for medium pressure ductwork and coating with more sealant to provide a vapor barrier. (This applies to all flex connections to diffusers, grilles, etc. when allowed on the drawings.)
- B. Insulated Acoustical Low Pressure Flexible Duct: Provide where indicated on drawings Flexmaster Type 1M UL181 Class I Air Duct. The duct shall be constructed of a CPE fabric supported by helical wound galvanized steel. The fabric shall be mechanically locked to the steel helix without the use of adhesives or chemicals. This flex duct material shall be used on exhaust duct for connecting air inlets (for general lab exhaust, not to be considered for connections to hoods, BSCs or equipment connections) to the distribution duct.

The internal working pressure rating shall be at least 6" w.g. positive and 4" w.g. negative with a bursting pressure of at least 2½ time the working pressure.

The duct shall be rated for a velocity of at least 4000 feet per minute. The duct must be suitable for continuous operation at a temperature range of -20° F to +250° F.

Acoustical performance, when tested by an independent laboratory in accordance with the Air Diffusion Council's Flexible Air Duct Test Code FD 72-R1, Section 3.0, Sound Properties, shall be as follows:

The insertion loss (dB) of a 10 foot length of straight duct when tested in accordance with ASTM E477, at a velocity of 2500 feet per minute, shall be at least:

Octave Band	2	3	4	5	6	7
Hz.	125	250	500	1000	2000	4000
6" diameter	7	31	40	38	40	27
8" diameter	13	29	36	35	38	22
12" diameter	21	28	29	33	26	12

The radiated noise reduction (dB) of a 10 foot length of straight duct when tested in accordance with ASTM E477, at a velocity of 2500 feet per minute, shall be at least:

Octave Band	2	3	4	5	6	7
Hz.	125	250	500	1000	2000	4000
6" diameter	5	8	7	8	11	15
8" diameter	10	7	7	8	10	13
12" diameter	9	6	6	5	9	13

The self generated sound power levels (LW) dB re 10-12 Watt of a 10 foot length of straight duct for an empty sheet metal duct when tested in accordance with ASTM E477, at a velocity of 1000 feet per minute, shall not exceed:

Octave Band	2	3	4	5	6	7
Hz.	125	250	500	1000	2000	4000
6" diameter	42	31	23	18	17	21
8" diameter	41	34	27	19	18	21
12" diameter	54	45	38	31	27	23

Factory insulate the flexible duct with fiberglass insulation. The R value shall be at least 4.2 at a mean temperature of 75° F. Cover the insulation with a fire retardant metalized vapor barrier jacket reinforced with crosshatched scrim having a permeance of not greater than 0.05 perms when tested in accordance with ASTM E96, Procedure A.

Total length of flex duct shall be limited to 10' with no more than 1/2" deflection per foot between supports. One 90 degree ell will be allowed when fitted with ThermaFlair FlexFlow Elbow accessory.

2.06 DUCT LINER: NOTE: ALL DUCTWORK SHALL BE EXTERNALLY INSULATED UNLESS OTHERWISE INDICATED ON THE PROJECT DRAWINGS. (See Section 23 07 19, for the applicable insulation specification.)

- A. Where indicated on the Drawings, ducts shall have lining equal to Johns Manville Permacote Linacoustic anti-microbial duct liner with factory applied edge coating. Duct liner shall be one inch (1") thick unless otherwise indicated. The liner shall be applied to the inside of the duct with heavy density side to the air stream and shall be secured in the duct with fireproof 3M #37 or St. Clair R41B adhesive, completely coating the clean sheet metal. All joints in the insulation shall be "buttered" and firmly butted tightly to the adjoining liner using fireproof

adhesive. Where a cut is made for duct taps, etc., the raw edge shall be accurately and evenly cut and shall be thoroughly coated with fireproof adhesive. On ducts over twenty-four (24") in width or depth, the liner shall be further secured with mechanical fasteners. The fasteners shall be A. J. Gerrard Company pronged straps, or approved equal, secured to the ducts by fireproof adhesive. The clips shall be eighteen inch (18") maximum spacing and shall be pointed up with fireproof adhesive. Liner shall be accurately cut and ends thoroughly coated with fireproof adhesive so that when the duct section is installed, the liner shall make a firmly butted and tightly sealed joint. Where ducts are lined exterior insulation will not be needed unless otherwise noted, except that the two insulations shall not lap less than twenty-four inches (24"). Dimensions given on the Drawings are metal sizes. Refer to Section 23 00 00 for Flame-Spread Properties.

2.07 FACTORY LINED ACOUSTICAL DUCTS: (NOTE: Must appear on the Drawings.)

- A. Where indicated on the Drawings, furnish and install double wall internally insulated duct and fittings.
- B. Duct shall consist of outer metal pressure shell, 1" thick glass fiber insulation and internal perforated metal liner.
- C. Duct and fittings shall be equal to Acousti-K 27 as manufactured by United McGill Sheet Metal Company.

PART 3 EXECUTION

3.01 INSTALLATION

- A. Refer also to requirements included in Part 2 of this specification.
- B. Obtain manufacturer's inspection and acceptance of fabrication and installation of fiberglass ductwork prior to beginning of installation.
- C. Provide openings in ductwork where required to accommodate thermometers and controllers. Provide pilot tube openings where required for testing of systems, complete with metal can with spring device or screw to ensure against air leakage. Where openings are provided in insulated ductwork, install insulation material inside a metal ring.
- D. Locate ducts with sufficient space around equipment to allow normal operating and maintenance activities.
- E. Connect diffusers or troffer boots to low pressure ducts with 2 feet maximum length of flexible duct. Hold in place with strap or clamp, and seal as specified.
- F. During construction provide temporary closures of metal or taped polyethylene on open ductwork to prevent construction dust from entering ductwork system.

3.02 LOW PRESSURE DUCT SUPPORTS:

- A. See Section 23 05 29.

3.03 DUCTWORK APPLICATION SCHEDULE

AIR SYSTEM	MATERIAL (2)	MINIMUM PRESSURE CLASSIFICATION
Supply/Exhaust/Return Systems:		
AHU Supply to Terminal Unit/Lab Control Valve	Galvanized Steel	Medium Pressure 6"
Downstream of terminal units	Galvanized Steel	Low Pressure

Notes to Table:

- (1) Air device connections may be made with insulated flexible duct as specified herein. Provide hard connections where specifically shown on the drawings.
- (2) Any duct exposed within occupied spaces (excluding mechanical rooms) shall be stainless.

3.05 CLEANING OF SYSTEMS:

- A. Before turning the installation over to the Owner, all ducts should be cleaned and blown free of all dust and dirt that has collected in the ducts.

END OF SECTION

SECTION 23 33 00
DUCTWORK ACCESSORIES

PART 1 GENERAL

1.00 The following sections are to be included as if written herein:

- A. Section 23 00 00 – Basic Mechanical Requirements
- B. Section 23 05 29 – Sleeves, Flashings, Supports and Anchors
- C. Section 23 05 53 – Mechanical Identification

1.01 WORK INCLUDED

- A. Volume control dampers.
- B. Air turning devices.
- C. Duct access doors.
- D. Duct test holes.

1.02 RELATED WORK

- A. Section 23 31 00 - Ductwork.

1.03 REFERENCES

- A. NFPA 90A - Installation of Air Conditioning and Ventilating Systems.
- B. SMACNA - Low Pressure Duct Construction Standards.
- C. UL 33 - Heat Responsive Links for Fire-Protection Service.
- D. UL 555 - Fire Dampers and Ceiling Dampers.

1.04 SUBMITTALS

- A. Submit shop drawings and product data under provisions of Section 23 00 00.
- B. Provide shop drawings for shop fabricated assemblies indicated, including volume control dampers duct access doors duct test holes. Provide product data for hardware used.
- C. Submit manufacturer's installation instructions under provisions of Section 23 00 00 for fire dampers and combination fire and smoke dampers.

PART 2 PRODUCTS

2.01 DAMPERS:

- A. Furnish and install dampers where shown on the Drawings and wherever necessary for complete control of the air flow, including all supply, return and exhaust branches, "division" in main supply, return and exhaust ducts, each individual air supply outlet and fresh air ducts.

Where access to dampers through a fixed suspended ceiling is necessary, the Contractor shall be responsible for the proper location of the access doors.

- B. Dampers shall be carefully fitted, and shall be controlled by locking quadrants equal to Ventlok No. 555 on exposed uninsulated ductwork, No. 644 on exposed externally insulated ductwork and No. 677 (2-5/8" diameter) chromium plated cover plate for concealed ductwork not above lay-in accessible ceilings. Furnish and install end bearings for the damper rods on the end opposite the quadrant when No. 555 or No. 644 regulators are used, and on both ends when No. 677 regulators are used.
- C. On concealed ductwork above lay-in accessible ceilings use Ventlok No. 555 or No. 644 locking quadrant for splitter dampers.
- D. Dampers larger than three (3) square feet in area shall be controlled by means of rods hinged near the leading edge of the damper with provisions for firmly anchoring the rod and with end bearings supporting the axle.
- E. Volume dampers shall be equal to those of Greenheck, Ruskin, Pottorff or substitute approved by Owner. Blades shall not exceed 48 inches (48") in length or twelve inches (12") in width and shall be of the opposed interlocking type. The blades shall be of not less than No. 16 gauge galvanized steel supported on one-half inch (1/2") diameter rust-proofed axles. Axle bearings shall be the self-lubricating ferrule type.
- F. Install all dampers furnished by the Temperature Control Manufacturer's in strict accordance with the manufacturer's recommendations and requirements of these Specifications.
- G. All adjustable dampers installed in externally insulated ductwork shall be installed with Ventlok No. 639, or equal, elevated dial operators. Insulation shall extend under the elevated dial. All adjustable dampers installed in internally insulated ductwork shall be installed with Ventlok No. 635, or equal, dial operators. All damper shaft penetrations in the ductwork shall be installed with Ventlok #609 end bearings.

2.02 ACCESS DOORS:

- A. Furnish and install in the ductwork, hinged rectangular or round "spin-in" access doors to provide access to all fire dampers mixed air plenums, upstream of steam reheat coils, automatic dampers, etc. Where the ducts are insulated, the access doors shall be double skin doors with one inch (1") of insulation in the door. Where the size of the duct permits, the doors shall be eighteen inches (18") by sixteen inches (16"), or eighteen inches in diameter, and shall be provided with Ventlok No. 260 latches (latches are not required in round doors). Latches for rectangular doors smaller than 18" x 16" shall be Ventlok No. 100 or 140. Doors for zone heating coils shall be Ventlok, stamped, insulated access doors, minimum 10" x 12", complete with latch and two (2) hinges, or twelve inches (12") in diameter. Round access doors shall be "Inspector Series" spin-in type door as manufactured by Flexmaster USA, or approved equal. Doors for personnel access to ductwork shall be nominal twenty-four inches (24") in diameter.
- B. Where these access doors are above a suspended ceiling, this Contractor shall be responsible for the proper location of the ceiling access doors.

2.03 TEST OPENINGS:

- A. Furnish and install in the return air duct and in the discharge duct of each fan unit Ventlok No. 699 instrument test holes. The test holes shall be installed in locations as required to

measure pressure drops across each item in the system, e.g., O.A. louvers, filters, fans, coils, intermediate points in duct runs, etc.

2.04 DUCT LOW PRESSURE TAPS (Conical Bell Mouth Fittings)

- A. All duct taps shall be made with low-loss taps, conical taps or full-sized bellmouth taps.
- B. Conical fittings may be used for duct taps and shall include quadrant dampers on all lines to air devices (diffusers and grilles) even though a volume damper is specified for the air device. (This does not apply to medium pressure duct.) Spin-in fittings shall be sealed at the duct tap with a gasket, or compression fit, or sealed with sealant specified for medium pressure ductwork. The location of spin-in fittings in the ducts shall be determined after dual or single duct terminal units are hung or the location of the light fixtures is known so as to minimize flexible duct lengths and sharp bends.
- C. The conical fitting shall be made of at least 26 gage galvanized sheet metal. The construction to be a two-piece fitting with a minimum overall length of 6 inches and shall be factory sealed for high pressure requirements. Average loss coefficient for sizes 6, 8, and 10 shall be less than 0.055.
- D. Each to be provided with minimum 24 gage damper plate with locking quadrant operator and sealed end bearings. Damper blade shall be securely attached to shaft to prevent damper from rotating around shaft.
- E. Provide flange and gasket with adhesive peel-back paper for ease of application. The fitting shall be further secured by sheet metal screws spaced evenly at no more than 4 inches on-center with a minimum of four screws per fitting.
- F. The conical bellmouth fitting shall be Series 3000G as manufactured by Flexmaster U.S.A., Inc., or Buckley Air Products, Inc., 'AIR-TITE'.

PART 3 EXECUTION

3.01 INSTALLATION

- A. Install accessories in accordance with manufacturer's instructions.
- B. Provide balancing dampers at points on low pressure supply, return, and exhaust systems where branches are taken from larger ducts as required for air balancing. Use splitter dampers only where indicated.
- C. Provide balancing dampers on medium pressure systems where indicated.
- D. Provide flexible connections immediately adjacent to equipment in ducts associated with fans and motorized equipment. Cover connections to medium and high pressure fans with leaded vinyl sheet, held in place with metal straps.
- E. Provide duct access doors for inspection and cleaning before and after duct mounted filters, coils, fans, automatic dampers, at fire dampers, and elsewhere as indicated. Provide minimum 8 x 8 inch (200 x 200 mm) size for hand access, 18 x 18 inch (450 x 450 mm) size for shoulder access, and as indicated.
- F. Provide duct test holes where indicated and where required for testing and balancing purposes. Refer also to Section 23 05 93.

END OF SECTION

SECTION 23 36 00
AIR TERMINAL UNITS

PART 1 - GENERAL

1.01 RELATED DOCUMENTS

- A. Drawings and general provisions of the Contract, including General Conditions and Division 01 Specification Sections, apply to this Section.
- B. Specifications throughout all Divisions of the Project Manual are directly applicable to this Section, and this Section is directly applicable to them.

1.02 SUMMARY

- A. Perform all Work required to provide and install the following products as indicated by the Contract Documents with supplementary items necessary for proper installation.
 - 1. Dual duct variable or constant volume terminal units.
 - 2. Integral controls.
 - 3. Integral sound attenuator.

1.03 REFERENCE STANDARDS

- A. The latest published edition of a reference shall be applicable to this Project unless identified by a specific edition date.
- B. All reference amendments adopted prior to the effective date of this Contract shall be applicable to this Project.
- C. All materials, installation and workmanship shall comply with the applicable requirements and standards addressed within the following references:
 - 1. NFPA 90A - Installation of Air Conditioning and Ventilation Systems.
 - 2. UL 181 - Factory-Made Air Ducts and Connectors.
 - 3. ARI Standard 880 for Air Terminals.
 - 4. ANSI/ASHRAE Standard 130 – Methods of Testing for Rating Ducted Air Terminal Units.

1.04 SUBMITTALS

- A. Product Data:
 - 1. Shop Drawings of product data indicating configuration, general assembly, access space required for service, and materials used in fabrication.
 - 2. Electronic or Printed Catalog performance ratings that indicate nominal inlet size, CFM, applicable static pressure at the inlet or discharge of terminal unit, and noise criteria with sound octave band and sound decibel test in accordance with ARI 880, for the insulation lining selected.
 - 3. Leakage curves indicating inlet static pressure and actual tested leakage rates shall be submitted for all non-standard or custom-built terminal units.

4. Unit manufacturer shall test and certify that each terminal unit used on this Project has been tested as specified.
- B. Record Documents:
1. Submit under provision of Division 01.
- C. Operation and Maintenance Data:
1. Operating instructions and maintenance manuals indicating maintenance and repair data, parts lists.
- D. Sample Units:
1. One sample, 8 inch size, production run unit of each type shall be submitted for examination and approval by the Engineer, Owner, and TAB Firm.
 2. This sample unit shall be submitted in addition to the required written submittal, well in advance of any requirement for installation of units, but absolutely no later than 60 calendar days after the Notice to Proceed with Construction.
 3. Contractor shall allow a minimum of three (3) weeks for testing of the sample unit from the time shipped to the TAB Firm. The TAB Firm will test double duct terminal for casing leakage, damper leakage, and the specification requirements. This period shall restart if the sample unit is rejected and another unit is resubmitted.
 4. If rejected for any reason, Contractor shall expedite the documented corrections and shall resubmit a sample unit as soon as possible.
 5. Any delay in submittal of the unit for approval shall not be grounds for Contractor's claim of delay. If approved, the unit shall remain in the possession of the Owner at the Project Site for comparison with units as shipped to the Project.
 6. Unit(s) shall be installed in the Project, at an accessible, marked location.

1.05 SHIPMENT TESTING PRIOR TO INSTALLATION

- A. Shipment Testing: At the Owner's discretion, a minimum of ten (10) percent of each size double duct terminal unit (but no less than one unit of each size on the Project) will be tested at the Project Site for casing leakage and damper leakage. Contractor shall allow sufficient time during construction for the TAB Firm to perform all testing as may be required.
- B. Unit Non-Performance:
1. If results of the shipment testing show that any of the units do not perform as specified, then an additional ten (10) percent of each size unit (but no less than one unit of a size, unless 100 percent of the size has been tested) shall be tested.
 2. If this testing, in the Owner's opinion, shows that ten (10) percent or more of the units tested do not perform as specified, then 100 percent of all unit sizes shall be tested for conformance with these Specifications.
 3. The results of that testing shall be reviewed carefully between the Contractor, manufacturer, Owner, and Engineer. A method of repair or replacement of units will be negotiated. The Owner, however, shall maintain the right of final approval of any proposed solution.

- C. Should for any reason, the testing as described in this Section prove that any of the units do not perform as specified, Contractor shall be responsible for all subsequent labor, travel, travel expenses and incidental expenses, penalties, or other costs attendant to any additional testing as described in this Section, or as required to prove that the units perform as specified. This shall include, but not be limited to, the labor, travel and reasonable incidental expenses of not only the Contractor and TAB Firm, but also those incurred by the Owner as may be specifically required for this purpose.

1.06 WARRANTY

- A. Provide one year manufacturer's warranty under provisions of Section 23 00 00.

PART 2 - PRODUCTS

2.01 GENERAL

- A. All materials shall meet or exceed all applicable referenced standards, federal, state and local requirements, and conform to codes and ordinances of authorities having jurisdiction.

2.02 MANUFACTURERS

- A. Manufacturer: Company specializing in manufacturing the products specified in this Section with minimum three (3) years documented experience.
- B. The same manufacturer shall provide all products supplied and/or installed under this Section.
- C. Manufacturers:
 - 1. Nailor Industries – 3200-UT

2.03 GENERAL CONSTRUCTION

- A. This section applies to dual duct terminal unit configurations as described within this Specification.
- B. Casing Construction:
 - 1. Units shall be constructed of 20 gage galvanized steel.
 - 2. All interior features of the boxes (such as mixing baffles, damper housings, etc.) shall be secured within the casing to avoid excessive movement or rattling with air movement or externally generated vibration.
 - 3. All external features of the terminal units shall be designed not to extend beyond the ends of the unit. For example, the actuator mounting brackets, etc. shall not extend beyond the plane of the inlet "bulkhead." The only exception shall be flow sensors installed in the inlet duct connections. Note that if a separate flow station is installed within a frame within the casing, then it shall be so installed not to allow airflow to bypass the flow measurement station.
 - 4. The access panel for the unit shall be on the bottom of the unit for access down through the ceiling.
- C. Ductwork Connections:

1. Construct units with inlet and discharge ductwork connections. The inlet ductwork connections shall extend a minimum of 4 inches from the unit casing including an allowance for the installation of airflow station(s) or probe(s).
2. The discharge connection shall include flange connection for use by the Contractor to secure the discharge ductwork or appurtenances to the unit and shall be reinforced to provide a rigid assembly.
3. External insulation shall be as specified in the Contract Documents for duct insulation with full vapor barrier.

D. Casing Liners:

1. Terminal unit casing shall be double wall lined with 1-inch thick, 1.5 lb density fiberglass insulation enclosed between the unit casing and a non-perforated, internal sheet metal cover. The interior wall cover shall be 22 gage galvanized steel. The interior wall cover shall extend over the fiberglass insulation and cover the liner cut edges. The exterior cover shall be 20 gage galvanized steel.
2. Insulation shall meet requirements of UL181 and NFPA 90A.
3. Casing shall be insulated throughout its interior.

E. Damper:

1. Damper blades shall be minimum 18 gage galvanized steel or equivalent aluminum and shall be securely riveted or bolted through the damper shafts to assure no slippage of the blades. The damper shafts shall operate in rustproof self-lubricating bearings. Damper shafts penetrating the unit casings shall be sealed against leakage and bearings shall be installed for protection against wear in the casing penetration. Damper shafts shall be formed of, or cut from solid stock; no hollow shafts will be allowed. The dampers shall seat against gasketed stops or the dampers shall have gasketed edges. The dampers shall be constructed with the proper rigidity to prevent deformation of the damper blade. The damper actuator linkage, if used, shall be constructed of material of sufficient strength to avoid buckling under extreme loads. Also, linkages shall not allow play greater than 5 degrees of damper movement. The controls for the dampers shall cause the dampers to fail in the position of last control (freeze in place), or fail to the open position.
2. Damper Leakage: Units shall be tested for inlet leakage with 4 inches w.g. static pressure imposed. The maximum percent leakage from all tests shall be reported. The following table provides the maximum allowable damper leakage for the various size diameter inlets at 4 inches w.g. differential pressure.

INLET DIAMETER (INCHES)	MAXIMUM ALLOWABLE CFM (AREA X 2000 FPM)	MAXIMUM ALLOWABLE CFM DAMPER LEAKAGE
4	200	6.0
6	400	6.0
8	700	11.0
10	1000	17.0
12	1500	20.0
14	2150	30.0

3. Flow Measurement: Airflow through the unit shall be accomplished by the use of a multi-port velocity pressure cross sensor or multi-axis flow ring devices with a minimum of four (4) radial distribution pick-up points connected to a center averaging chamber. The chamber is to be designed with adequate internal passages to prevent restrictions that can possibly contribute to control 'hunting'. Calibration of each terminal unit with the building automation system (BAS) Provider's controller is to be performed by the manufacturer prior to shipping the terminal unit to the Project Site.
4. Thermal Anemometry: Terminal Unit Velocity Sensors (Applicable only to a Single Point Probe): The probe shall utilize thermal anemometry as the sensing technique. Velocity range shall be 0 to 3250 feet per minute (fpm) and with an installed accuracy of ± 25 fpm. The velocity probe shall include an insertion type-mounting bracket that mounts flush to the supply duct. The velocity probe shall be mounted parallel to the damper shaft with 1/3 or 2/3 penetration into the duct. The velocity probe shall be mounted a minimum of two duct diameters upstream of the terminal inlet for the pneumatic system. For the BAS, both sensors shall be mounted immediately upstream of the terminal unit.]Electronic probes shall be temperature compensated.

F. Unit Controls:

1. General Performance: Flow stations, control transformers, disconnect switch, and controls enclosure shall be furnished, mounted and adjusted by the terminal unit manufacturer to assure their proper placement within the units. If DDC controls of another manufacturer (not the terminal unit manufacturer) are provided for the Project, the terminal unit manufacturer shall be responsible only for construction of the terminal unit and installation of internal control components installed at the manufacturer's factory and shall not be responsible for installation of controls not installed at the terminal unit manufacturer's factory, nor shall the manufacturer be responsible for the performance of the DDC controls. The performance of DDC controls in connection with terminal units shall be the responsibility of the BAS Provider.
2. Control Performance: Assemblies shall be able to be reset to any airflow between zero and the maximum CFM shown on Drawings. To allow for maximum future flexibility, it shall be necessary to make only simple screwdriver or keyboard adjustments to arrange each unit for any maximum airflow within the ranges for each inlet size as scheduled on the Drawings. The control devices shall be designed to maintain the desired flow regardless of inlet flow deflection.
3. Control Sequences: The control sequence arrangements shall be as described on the Drawings. Terminal units shall be shipped from the manufacturer with all necessary control devices to accomplish each sequence, except as may be prohibited by the BAS Provider. The desired sequence shall be adjustable according to space usage or a change in space conditions.

G. DDC Controls Protocol/Description:

1. BAS Provider will be responsible for providing all damper actuators, linkages, flow transducers, controllers, room temperature sensors, and any other devices required for unit control, except as specified below.
2. BAS Provider will be responsible for calibrating the actuator and its controller through TAB work for scheduled airflow rates. Units shall be capable of field calibration and readjustment with external gauge taps.
3. Unit manufacturer shall provide unit inlet flow sensor and pneumatic tubing for BAS Provider's use.

4. Unit manufacturer shall factory install all devices furnished by BAS Provider to result in a complete functioning unit. Unit manufacturer shall be responsible for reviewing compatibility of devices furnished by BAS Provider to units provided.

H. Pressure and Leakage Certification:

1. Manufacturer shall certify that each unit used on the Project will perform as specified. Each unit shall bear a tag or decal listing the following specified information:
 - a. Test pressure.
 - b. Leakage CFM (damper).
 - c. Leakage CFM.
 - d. Date of manufacture.
 - e. Name of person performing test.

2.04 DUAL DUCT VARIABLE OR CONSTANT VOLUME TERMINAL UNITS

- A. Pressure independent, dual duct variable or constant air volume control assemblies with attenuator-mixers of the sizes, capacities and configurations as scheduled on the Drawings.
- B. Unit Pressure Drop: For dual duct units with an integral attenuator-mixer, but with no other accessories, the static pressure across the assembly with an equivalent 2000 fpm inlet velocity through one inlet shall not exceed 0.50 inches water gauge, with the total flow through either inlet.
- C. Mixing:
 - a. Dual duct terminal units as specified herein shall provide mixing within the units and not rely upon the discharge ductwork to provide for completion of the mixing process.
 - b. The horizontal average temperature of the air as it leaves the terminal unit shall not vary more than 1 degree F for each 10 degrees F of temperature difference between the two inlet air supplies.
 - 1) For example, if the cold supply air is 55 degrees F and the hot supply air is 95 degrees F, the difference is 40 degrees. The allowable temperature variation of the discharge air is, thus, 4 degrees F.
 - c. The temperature of the discharge air shall be measured using a pattern of four (4) vertical, evenly spaced columns and three horizontal, evenly spaced rows.
 - d. The rows and columns shall be spaced so that the resulting 12 points shall be at the centers of equal areas. The plane of the points shall be perpendicular to the direction of airflow, within four (4) inches of the discharge of the terminal unit, within the discharge ductwork. The three readings in each column shall be averaged to determine compliance with the 1 degree F criteria.

PART 3 - EXECUTION

3.01 INSTALLATION

- A. Installation shall meet or exceed all applicable federal, state and local requirements, referenced standards and conform to codes and ordinances of authorities having jurisdiction.
- B. All installation shall be in accordance with manufacturer's published recommendations.
- C. Provide clearance for inspection, repair, replacement, and service. Ensure accessibility to all terminal unit electrical control panel doors, controllers and operators are located a minimum of 30 inches from all obstructions (walls, pipe, etc.).
- D. Provide ceiling access doors or locate units above easily removable ceiling components.
- E. Install terminal units with the manufacturer's recommended minimum number of diameters of straight duct directly prior to the entry into each terminal unit connection. If the existing conditions cannot provide that number of diameters, please contact the Engineer to look at the situations specifically.
- F. Support units individually from structure. Do not support from adjacent ductwork. For terminal units that are not internally isolated, refer to Section 20 05 48 for terminal unit vibration isolation requirements. Terminal units shall be supported using units hanger brackets and threaded rods.
- G. Connect to ductwork in accordance with Section 23 31 00.
- H. Wiring and controller compartments and damper motors shall have a minimum 24 inch clear wide and deep working space readily accessible from lift out ceiling tiles or access panels. All dual-duct control power shall be low-voltage control power only.

END OF SECTION 23 36 00

SECTION 23 37 00
AIR OUTLETS AND INLETS

PART 1 GENERAL

1.01 WORK INCLUDED

- A. Diffusers.
- B. Diffuser boots.
- C. Registers/grilles.

1.02 RELATED WORK

- A. Section 09 91 00 - Painting: Painting of ductwork visible behind outlets and inlets.
- B. Section 23 00 00 - Basic Mechanical Requirements.
- C. Section 23 31 00 - Ductwork.
- D. Section 23 33 00 - Ductwork Accessories.

1.03 REFERENCES

- A. ADC 1062 - Certification, Rating and Test Manual.
- B. AMCA 500 - Test Method for Louvers, Dampers and Shutters.
- C. ANSI/NFPA 90A - Installation of Air Conditioning and Ventilating Systems.
- D. ARI 650 - Air Outlets and Inlets.
- E. ASHRAE 70 - Method of Testing for Rating the Air Flow Performance of Outlets and Inlets.
- F. SMACNA - Low Pressure Duct Construction Standard.

1.04 QUALITY ASSURANCE

- A. Test and rate performance of air outlets and inlets in accordance with ADC Equipment Test Code 1062 and ASHRAE 70.
- B. Test and rate performance of louvers in accordance with AMCA 500.

1.05 REGULATORY REQUIREMENTS

- A. Conform to ANSI/NFPA 90A.

1.07 SUBMITTALS

- A. Submit product data under provisions of Section 23 00 00.
- B. Provide product data for items required for this project.

- C. Submit schedule of outlets and inlets indicating type, size, location, application, and noise level.
- D. Review requirements of outlets and inlets as to size, finish, and type of mounting prior to submitting product data and schedules of outlets and inlets.
- F. Submit manufacturer's installation instructions under provisions of Section 23 00 00.

PART 2 PRODUCTS

2.01 AIR SUPPLIES AND RETURNS:

- A. Grilles, registers and ceiling outlets shall be as scheduled on the Drawings and shall be provided with sponge rubber or soft felt gaskets. If a manufacturer other than the one scheduled is used, the sizes shown on the Drawings shall be checked for performance, noise level, face velocity, throw, pressure drop, etc., before the submittal is made. Selections shall meet the manufacturer's own published data for the above performance criteria. The throw shall be such that the velocity at the end of the throw in the five foot occupancy zone will be not more than 50 FPM nor less than 25 FPM. Noise levels shall not exceed those published in the ASHRAE Guide for the type of space being served (NC level). Grilles, registers and ceiling outlets shall be Nailor, Titus, or Metal*Aire.
- B. Locations of outlets on Drawings are approximate and shall be coordinated with other trades to make symmetrical patterns and shall be governed by the established pattern of the lighting fixtures or architectural reflected ceiling plan. Where called for on the schedules, the grilles, registers and ceiling outlets shall be provided with deflecting devices and manual damper. These shall be the standard product of the manufacturer, subject to review by the Architect, and equal to brand scheduled.

2.02 ACCEPTABLE MANUFACTURERS - CEILING DIFFUSERS

- A. Titus.
- B. Nailor
- C. Metalaire

PART 3 EXECUTION

3.01 INSTALLATION

- A. Install items in accordance with manufacturers' instructions.
- B. Check location of outlets and inlets and make necessary adjustments in position to conform with architectural features, symmetry, and lighting arrangement. Refer to Section 09 91 00.
- C. Install diffusers to ductwork with air tight connection.
- D. Provide balancing dampers on duct take-off to diffusers, and grilles and registers, regardless of whether dampers are specified as part of the diffuser, or grille and register assembly. Where take-off dampers are accessible, dampers at the air device should be omitted.
- E. Paint ductwork visible behind air outlets and inlets matte black. Refer to Section 09 91 00.

END OF SECTION

SECTION 26 00 00

BASIC ELECTRICAL REQUIREMENTS

PART 1 - GENERAL

1.1 WORK INCLUDED

- A. General Requirements specifically applicable to Division 26.
- B. The Contractor shall be responsible for:
 - 1. The work included consists of furnishing all materials, supplies, equipment and tools, and performing all labor and services necessary for installation of a completely functional power, lighting, fire alarm and signaling systems. Complete systems in accordance with the intent of Contract Documents.
 - 2. Coordinating the details of facility equipment and construction for all Specification Divisions, which affect the work covered under this Division.
 - 3. Furnishing and installing all incidental items not actually shown or specified, but which are required by good practice to provide complete functional systems.
 - 4. Temporary power service and lighting for construction. Coordinating all shutdown dates and schedules with Owner's Representative and obtain all work-permits required by Owner.
- C. Intent of Drawings:
 - 1. The Drawings are necessarily diagrammatic by their nature, and are not intended to show every connection in detail or every device or raceway in its exact location, unless specifically dimensioned. The Contractor shall carefully investigate structural and finish conditions and shall coordinate the work in order to avoid interference between the various phases of work. The Contractor shall be responsible for the proper routing of raceway, subject to prior review by the Owner and Engineer. Work shall be organized and laid out so that it will be concealed in furred chases and suspended ceilings, etc., in finished portions of the building, unless specifically noted to be exposed. All work shall be installed parallel or perpendicular to the lines of the building unless otherwise noted.
 - 2. The intent of the Drawings is to establish the type of systems and functions, but not to set forth each item essential to the functioning of the system. The drawings and specifications are cooperative, and work or materials called for in one and not mentioned in the other shall be provided. Review pertinent drawings and adjust the work to conditions shown. In case of doubt as to work intended, or where discrepancies occur between drawings, specifications, and actual conditions, immediately notify the Architect/Engineer and the Owner's representative, and propose a resolution.

1.2 RELATED WORK

- A. This Section shall be used in conjunction with the following other specifications and related Contract Documents to establish the total general requirements for the project electrical systems and equipment.
 - 1. Division 01 Sections included in the project specifications.
 - 2. The contract.

1.3 DESIGN CRITERIA

- A. Equipment and devices to be installed outdoors or in enclosures where the temperatures are not controlled shall be capable of continuous operation under such conditions per manufacturer's requirements.
- B. Compliance by the Contractor with the provisions of this Specification does not relieve him of the

responsibilities of furnishing equipment and materials of proper design, mechanically and electrically suited to meet operating guarantees at the specified service conditions.

- C. Electrical components shall be UL listed and labeled.

1.4 REFERENCE CODES AND STANDARDS, REGULATORY REQUIREMENTS

- A. Standards of the following organizations as well as those listed in Division 01, may be referenced in the specification. Unless noted otherwise, references are to standards or codes current at the time of bidding.

1. Association of Edison Illuminating Companies (AEIC)
2. American National Standards Institute (ANSI)
3. Institute of Electrical and Electronics Engineers (IEEE)
4. Insulated Cable Engineers Association (ICEA)
5. National Electrical Code (NEC)
6. National Electrical Manufacturers Association (NEMA)
7. Electrical Safety in the Workplace
8. National Fire Protection Association (NFPA)
9. Underwriter's Laboratories (UL)
10. ASHRAE/IES 90.1 – Energy Standard for Buildings Except Low-Rise Residential Buildings

- B. Work, materials and equipment must comply with the latest rules and regulations of the following.

1. National Electrical Code (NEC)
2. Electrical Safety in the Workplace
3. Occupational Safety and Health Act (OSHA)
4. American with Disability Act (ADA)
5. American Society for Testing and Materials (ASTM)
6. University of Texas (UT) System
7. Applicable state and federal codes, ordinances and regulations

- C. Discrepancies. The drawings and specifications are intended to comply with listed codes, ordinances, regulations and standards. Where discrepancies occur, immediately notify the Owner's representative in writing and ask for an interpretation. Should installed materials or workmanship fail to comply, the Contractor is responsible for correcting the improper installation. Additionally, where sizes, capacities, or other such features are required in excess of minimum code or standards requirements, provide those specified shown.

- D. Contractor shall obtain permits and arrange inspections required by codes applicable to this Section and shall submit written evidence to the Owner and Engineer that the required permits, inspections and code requirements have been secured.

1.5 SUBMITTALS

- A. Submit the following in addition to and in accordance with the requirements of Division 01 for submittal requirement.

1. Include inspection and permit certificates and certificates of final inspection and acceptance from the authority having jurisdiction.
2. Manufacturer's standardized schematic diagrams and catalog cuts shall not be acceptable unless applicable portions of it are clearly indicated and non-applicable portions clearly deleted or crossed out.

3. All schematic, connection and/or interconnection diagrams in accordance with the latest edition of NEMA.
 4. Provide submittals as required by individual specification Section.
- B. Provide the following with each submittal:
1. Catalog cuts with manufacturer's name clearly indicated. Applicable portions shall be circled and non-applicable portions shall be crossed out.
 2. Line-by-line specification review by equipment manufacturer and contractor with any exceptions explicitly defined.
- C. Equipment Layout Drawing: 1/8-inch scale minimum drawings indicating electrical equipment locations. Dimensions for housekeeping pads should be indicated on these drawings. Indicate routing of conduit 2 inches and over on these drawings.
- D. Within the specified time window after award of contract, submit list of equipment and materials to be furnished.
1. Itemize equipment and material by specification Section number; include manufacturer and identifying model or catalog numbers.
 2. Replace rejected items with an acceptable item within 2 weeks after notification of rejection.
 3. If a satisfactory replacement is not submitted within a two-week period, owner will notify contractor as to equipment manufacturer or type and make or material to be furnished. Provide designated items at no additional cost to owner.
- E. As-Built Record Drawings: The Contractor shall maintain a master set of As-Built Record Drawings that show changes and any other deviations from the drawings. The markups must be made as the changes are done. At the conclusion of the job, these As-Built Record Drawings shall be transferred to AutoCad electronic files, in a format acceptable to the Owner, and shall be complete and delivered to the Owner's Representative prior to final acceptance. Refer to 01210 Project Administration for other requirements.

1.6 SAFETY

- A. The Contractor shall follow the safety procedures in addition to, and in accordance with, the requirements of Project Safety Manual (PSM).
1. The Contractors shall be responsible for training all personnel under their employ in areas concerning safe work habits and construction safety. The Contractor shall continually inform personnel on hazards particular to this project and update the information as the project progresses.
 2. The Contractor shall secure all electrical rooms, to limit access, prior to energizing any high voltage (480V or higher) equipment and shall control access during the project after energization. The Contractor shall post and maintain warning and caution signage in areas where work is on going near energized equipment. The Contractor shall cover all energized live parts when work is not being done in the equipment. This includes lunch and breaks.
 3. The Contractor shall strictly enforce OSHA lock out/tag out procedures. Initial infractions shall result in a warning; a second infraction shall result in the removal of the workman and his foreman from the site. Continued infractions shall result in removal of the Contractor from the site.

1.7 SHORING AND EQUIPMENT SUPPORTS

- A. The Contractor shall provide all permanent and temporary shoring, anchoring, and bracing required to make all parts absolutely stable and rigid; even when such shoring, anchoring, and bracing are not explicitly called for.
- B. The Contractor shall adequately support all freestanding panels, motor control centers,

enclosures, and other equipment. This shall include bolting to the floor or solid structural steel to prevent tipping. Install free-standing electrical equipment on 4" thick concrete housekeeping pads that are provided by others. Under no condition shall equipment be fastened to non-rigid building steel (i.e., removable platform steel gratings, handrails, etc.).

- C. The Contractor shall provide racks and supports, independently mounted at structure, to support electrical equipment and systems supplied and installed under this contract. At no time shall the Contractor mount or suspend equipment from other disciplines' supports.

1.8 TEMPORARY POWER REQUIREMENTS

- A. Provide power distribution system sufficient to accommodate construction operations requiring power, use of power tools, electrical heating, lighting, and start-up/testing of permanent electric-powered equipment prior to its permanent connection to electrical system. Provide proper overload protection. Ground fault circuit interrupters (GFCI) are to be used on all 120-volt, single-phase, 15 and 20 amp receptacle outlets where portable tools and equipment are used. Ground fault circuit interrupters shall be tested weekly by the Contractor.
- B. Temporary power feeders shall originate from a distribution panel. The conductors shall be multi-conductor cord or cable per NEC for hard and extra-hard service multi-conductor cord.
- C. Branch circuits shall originate in an approved receptacle or panelboard. The conductors shall be multi-conductor cord or cable per NEC for hard and extra-hard service multi-conductor cord. Each branch circuit shall have a separate equipment grounding conductor.
- D. All receptacles shall be of the grounding type and electrically connected to the grounding conductor.
- E. Provide temporary lighting by factory-assembled lighting strings or by manually-assembled units. All lamps for general lighting shall be protected from accidental contact or breakage. Protection shall be provided by installing the lights a minimum of 7 feet from the work surface or by lamp holders with guards. Branch circuits supplying temporary lighting shall not supply any other load. Provide sufficient temporary lighting to ensure proper workmanship by combined use of day lighting, general lighting, and portable plug-in task lighting. Comply with OSHA required foot-candle levels and submit plan for approval by the owner.
- F. For temporary wiring over 600 volts, suitable fencing, barriers, or other effective means shall be provided to prevent access of anyone other than authorized and qualified personnel.
- G. Temporary power cords shall be kept off the ground or floor. The Contractor shall provide temporary supports as required to keep temporary cords off the ground or floor.

1.9 SUBSTITUTION OF MATERIALS AND EQUIPMENT:

- A. Refer to Uniform General Conditions and Supplementary General Conditions for substitution of materials and equipment.
- B. The intent of the Drawings and/or Specifications is neither to limit products to any particular manufacturer nor to discriminate against an "APPROVED EQUAL" product as produced by another manufacturer. Some proprietary products are mentioned to set a definite standard for acceptance and to serve as a reference in comparison with other products. When a manufacturer's name appears in these Specifications, it is not to be construed that the manufacturer is unconditionally acceptable as a provider of equipment for this project. The successful manufacturer or supplier shall meet all of the provisions of the appropriate specification(s).
- C. The specified products have been used in preparing the Drawings and Specifications and thus establish minimum qualities with which substitutes must at least equal to be considered acceptable. The burden of proof of equality rests with the Contractor. The decision of the Architect/Engineer is final.

- D. When requested by the Architect/Engineer, the Contractor shall provide a sample of the proposed substitute item. In some cases, samples of both the specified item and the proposed item shall be provided for comparison purposes.
- E. Timeliness: The burden of timeliness in the complete cycle of submittal data, shop Drawings, and sample processing is on the Contractor. The Contractor shall allow a minimum of six (6) weeks time frame for review of each submission by the office of the design discipline involved after receipt of such submissions by that design discipline. The Contractor is responsible for allowing sufficient time in the construction schedule to cover the aforementioned cycles of data processing, including time for all resubmittal cycles on unacceptable materials, equipment, etc. covered by the data submitted. Construction delays and/or lack of timeliness in the above regard are the responsibility of the Contractor and will not be considered in any request for scheduled construction time extensions and/or additional costs to the Owner.
- F. All equipment installed on this project shall have local representation; local factory authorized service, and a local stock of repair parts.
- G. Acceptance of materials and equipment will be based on manufacturer's published data and will be tentative subject to the submission of complete shop Drawings indicating compliance with the contract documents and that adequate and acceptable clearances for entry, servicing, and maintenance will exist. Acceptance of materials and equipment under this provision shall not be construed as authorizing any deviations from the Specifications, unless the attention of the Architect/Engineer has been directed in writing to the specific deviations. Data submitted shall not contain unrelated information unless all pertinent information is properly identified.
- H. Certification: The Contractor shall carefully examine all data forwarded for approval and shall sign a certificate to the effect that the data has been carefully checked and found to be correct with respect to dimensions and available space and that the equipment complies with all requirements of the Specifications.
- I. Physical Size of Equipment: Space is critical; therefore, equipment of larger sizes than shown, even though of specified manufacturer, will not be acceptable unless it can be demonstrated that ample space exists for proper installation, operation, and maintenance.
- J. Should a substitution be accepted, and should the substitute material prove defective, or otherwise unsatisfactory for the service intended within the guarantee period, this material or equipment shall be replaced with the material or equipment specified at no additional cost to the Owner.

PART 2 - PRODUCTS

2.1 MATERIALS AND EQUIPMENT

- A. Materials and Equipment: Labeled and/or listed as acceptable to the authority having jurisdiction as suitable for the use intended. Materials shall be of a standard industrial quality if no specifications or specific model numbers are given.
- B. Where two or more units of the same class of material are required, provide products of a single manufacturer. Component parts of materials or equipment need not be products of the same manufacturer.
- C. All materials shall be new and unused.
- D. Provide non-metallic material in corrosive areas or as otherwise specified.

PART 3 - EXECUTION

3.1 WORKMANSHIP

- A. Install work in compliance with NEC latest edition.
- B. Install material and equipment in accordance with manufacturers' instructions. Provide calibrated torque wrenches and screwdrivers and tighten all terminals, lugs, and bus joints using it.

- C. Comply with startup procedures as defined by Construction Manager and Owner.
- D. Arrange electrical work in a neat, well-organized manner. Do not block future connection points of electrical service. Install all electrical work parallel or perpendicular to building lines unless noted otherwise, properly supported with purpose-designed apparatus, in a neat manner.
- E. Apply, install, connect, erect, use, clean, adjust, and condition materials and equipment as recommended by the manufacturers in their published literature.
- F. Make opening through masonry and concrete by core drilling in acceptable locations. Restore openings to original condition to match remaining surrounding materials.

3.2 SERVICE CONTINUITY

- A. Maintain continuity of electric service to all functioning portions of process or buildings during the hours of normal use. Phase construction work to accommodate Owner's occupancy requirements.
- B. Arrange temporary outages for cutover work with the Owner. Keep the outages to a minimum number and minimum length of time.
- C. All service outages shall be requested in writing a minimum of two weeks prior to the date. Owner reserves the right to postpone shutdowns up to 24 hours prior to the shutdown at no additional cost. Outage requests shall include a schedule of the work to be performed and the time requirements.
- D. The Contractor shall obtain all appropriate Owner permits for working in equipment.

3.3 HAZARDOUS LOCATIONS

- A. Equipment, wiring, devices, and other components located within hazardous areas to be of appropriate type per NFPA requirements.
- B. Ground exposed non-current carrying parts of entire electrical system in hazardous areas, in accordance with NEC and as instructed by Owner.

3.4 SLEEVES AND SEALS

- A. Provide sealing and/or fire stopping where electrical equipment passes through walls, ceilings, and floors. Seals shall be watertight and/or fire rated as applicable.

3.5 CONSTRUCTION REVIEW

- A. The Engineer or Owner's representative will review and observe installation work to insure compliance by the Contractor with requirements of the Contract Documents.
- B. Review, observation, assistance, and actions by the Engineer or Owner's representative shall not be construed as undertaking supervisory control of the work or of methods and means employed by the Contractor. The review and observation activities shall not relieve the Contractor from the responsibilities of these Contract Documents.
- C. The fact that the Engineer or Owner's representative do not make early discovery of faulty or omitted work shall not bar the Engineer or Owner's representative from subsequently rejecting this work and insisting that the Contractor make the necessary corrections.
- D. Regardless of when discovery and rejection are made, and regardless of when the Contractor is ordered to correct such work, the Contractor shall have no claim against the Engineer or Owner's representative for an increase in the Contract price, or for any payment on account of increased cost, damage, or loss.

3.6 WARRANTY

- A. Provide warranties in accordance with the requirements of Uniform General and Supplementary Conditions (UGC).

END OF SECTION

SECTION 26 00 00.01

ELECTRICAL DEMOLITION

PART 1 - GENERAL

1.1 WORK INCLUDED

- A. Electrical demolition for remodeling.
- B. Electrical/control portion of HVAC work covered by Division 23 pertaining electrical demolition shall follow the requirement set forth by this specification.

1.2 RELATED WORK

- A. This Section shall be used in conjunction with the following other specifications and related Contract Documents to establish the total requirements for minor electrical demolition for remodeling.
 - 1. Section 26 00 00 - Basic Electrical Requirements.
- B. In the event of conflict regarding minor electrical demolition requirements between this Section and any other Section, the provisions of this Section shall govern.

PART 2 - PRODUCTS

2.1 MATERIALS AND EQUIPMENT

- A. Materials and equipment for patching and extending work: as specified in individual Sections.
- B. Provide all materials necessary for work.

PART 3 - EXECUTION

3.1 EXAMINATION

- A. All demolitions or modifications to existing systems shall be coordinated through Owner's Representative. Demolition drawings are based on casual field observation and existing record documentations. Therefore the accuracy or exactness of the drawings is not guaranteed. The Contractor shall verify that field measurements and circuiting arrangements are as shown on Drawings and abandoned wiring and equipment serve only abandoned facilities. The Contractor shall be responsible for reporting discrepancies to Engineer before disturbing existing installation.
- B. Beginning of demolition means Contractor accepts existing conditions.

3.2 PREPARATION

- A. Disconnect electrical systems in walls, floors, and ceilings scheduled for removal. Provide temporary wiring and connections to maintain remaining systems in service during demolition and/or modification. Owner reserves the right up to 24 hours prior to any scheduled event to delay or suspend shutdowns or outages to more convenient times at no additional cost.
- B. Existing Electrical Service: Maintain existing system in service until new system is complete and ready for service. No work shall begin without proper permits and authorizations. Disable system only to make switchovers and connections. Obtain permission from Owner at least (2) weeks before partially or completely disabling system. Minimize outage duration. Make temporary connections to maintain service in areas adjacent to work area.
- C. Existing Fire Alarm System: Maintain existing system in service until new system is accepted. Disable system only to make switchovers and connections. Notify Owner at least (2) weeks before partially or completely disabling system. Minimize outage duration. Provisions for manual fire watch shall be provided in areas where services are interrupted. Make temporary connections to maintain service in areas adjacent to work area.

- D. Existing Telephone System: Maintain existing system in service until new system is complete and ready for service. Disable system only to make switchovers and connections. Notify Owner at least (2) weeks before partially or completely disabling system. Minimize outage duration. Make temporary connections to maintain service in areas adjacent to work area.

3.3 DEMOLITION AND EXTENSION OF EXISTING ELECTRICAL WORK

- A. Remove, relocate, and extend existing installations to accommodate new plan drawings.
- B. Remove exposed abandoned conduit, including abandoned conduit above accessible ceiling finishes full length from source to device. Cut embedded or concealed conduit flush with walls and floors, and patch surfaces.
- C. Disconnect abandoned outlets and remove devices. Remove abandoned outlets if conduit servicing them is abandoned and removed. Provide blank cover for abandoned outlets that are not removed.
- D. Disconnect and remove abandoned panelboards and distribution equipment.
- E. Disconnect and remove electrical devices and equipment serving utilization equipment that has been removed.
- F. Disconnect and remove abandoned luminaires. Remove brackets, stems, hangers, and other accessories.
- G. Repair adjacent construction and finishes damaged during demolition and extension work.
- H. Maintain access to existing electrical installations that remain active. Modify installation or provide access panel as appropriate.
- I. Extend existing installations using materials and methods compatible with existing electrical installation or as specified.
- J. The level of completion shall be demonstrated to Owner's Representative.
- K. Where equipment is indicated to be demolished and returned to Owner, the Contractor shall include the delivery of this equipment to the Owner's site storage area. Remove with care all equipment to be relocated. Repair or replace of newly damaged equipment is the responsibility of the Contractor.

3.4 CLEANING AND REPAIR

- A. The Contractor shall follow Owner's clean work policy and shall include the removal of trash and demolished material from the building or work area at the end of the each day and removal from the site once a week.
- B. The Contractor shall be responsible for repairing adjacent construction and finishes damaged during demolition and/or modification. The Contractor shall be responsible for the removal of ceiling tiles required in the demolition work. The Contractor shall be responsible for the replacement of damaged tiles and reinstallation of the ceiling prior to final acceptance.
- C. Panelboards: Clean exposed surfaces and check tightness of electrical connections. Replace damaged circuit breakers and provide closure plates for vacant positions. Provide typed circuit directory showing revised circuiting arrangement.
- D. Luminaires: Remove existing luminaires for cleaning. Use mild detergent to clean all exterior and interior surfaces; rinse with clean water and wipe dry. Replace lamps, ballasts, and broken electrical parts.

3.5 DISPOSITION OF MATERIAL AND EQUIPMENT

- A. Review with the Owner materials that have been removed and are no longer required, to determine any which the Owner may desire to keep. Deliver those materials that the Owner desires to the Owner's specified location.

- B. For those materials not required by the Owner, dispose of them in accordance with applicable regulations.

END OF SECTION

SECTION 26 05 00

BASIC ELECTRICAL MATERIALS AND METHODS

PART 1 - GENERAL

1.1 WORK INCLUDED

- A. Hinged cover enclosures and cabinets
- B. Contactors
- C. Control relays
- D. Push buttons, and selector switches
- E. Terminal blocks and accessories
- F. Penetration sealing systems (fire stops)
- G. Electrical/control portion of HVAC work covered by Division 23 pertaining basic electrical materials and methods shall follow the requirement set forth by this specification.

1.2 APPLICABLE CODES AND STANDARDS

- A. NFPA 70, National Electrical Code (latest edition)
- B. American National Standard, National Electrical Safety Code, (latest edition)
- C. Applicable publications of NEMA, ANSI, IEEE, and ICEA
- D. Underwriters Laboratories, Inc. Standards (UL)
- E. Federal, city, state, and local codes and regulations having jurisdiction
- F. OSHA requirements
- G. NEMA 250 - Enclosures for Electrical Equipment (1000 Volts Maximum)
- H. NEMA WD 1 – General-Purpose Wiring Devices
- I. UL 98 - Enclosed Switches

1.3 INTENT

- A. This Section is not, and shall not be interpreted to be, a complete listing of all materials or equipment that is Contractor furnished and erected. It is intended to clarify and further define the Contractor scope of work, procurement, and responsibilities for those incidental materials that are not specified by other specifications, but important to a complete and operational system.
- B. The Contractor shall furnish all equipment and materials, whether or not specified in other Sections of specification and on drawings, for installation and connection required to place equipment into satisfactory operating service. The Contractor shall review the Drawings and specifications for clarification of his responsibility in the handling and installation of equipment and material. Where applicable, and not in contradiction with the Drawings and specifications, the Contractor shall install and connect the equipment in accordance with the manufacturer's recommendations and instructions.
- C. All materials and equipment shall be of types and manufacturer specified wherever practical. Should materials or equipment so specified be unattainable, the Contractor shall submit the description and manufacturer's literature, reason for substitution request and shall secure the approval of the Engineer before substitution of other material or equipment is purchased. This Section establishes performance requirements and the quality of equipment acceptable for use and shall in no way be construed to limit procurement from other manufacturer.

1.4 SUBMITTALS

- A. Provide submittals in addition and in accordance with Section 26 00 00, Basic Electrical Requirements, and Division 01 for submittal requirement.
- B. Submit manufacturer's literature and specification data sheets for each type of basic material, which is applicable to the project.

1.5 DELIVERY, STORAGE AND HANDLING

- A. Provide factory-wrapped waterproof flexible barrier material for covering materials, where applicable, to protect against physical damage in transit. Damaged materials shall be removed from project site.
- B. In their factory-furnished coverings, store materials in a clean, dry indoor space, which provides protection against the weather.

PART 2 - PRODUCTS

2.1 PENETRATION SEALING SYSTEMS (FIRE STOPS)

- A. Provide penetration sealing where conduit, cable tray, etc. pass through rated walls, ceilings, and floors. See Section 07840, Fire Stopping, and Section 07900, Joint Sealants, for sealing requirements and systems.

2.2 UL LISTING

- A. All equipment and materials shall be new and conform to the requirements of this Section. All equipment and materials shall be UL listed, and shall bear their label whenever standards have been established and level service is regularly furnished. All equipment and materials shall be of the best grade of their respective kind for the purpose.

PART 3 - EXECUTION

3.1 ERECTION OF EQUIPMENT

- A. Manufacturer's Installation Instructions: Where furnished or called for by the manufacturer equipment manufacturer's installation instructions shall be considered a part of this specification and fully complied with. Where the Contractor damages the finishing coat of paint in existing or completed areas, he shall refinish with matching paint.
- B. Mounting Heights: Individual safety switches and buttons and devices shall normally be installed at the following mounting heights, when not specified on the Drawings.
 - 3. Control Panels: 6 feet 0 inches (to top).
- C. Mounting: Equipment and control devices shall be supported independent of conduit connections. Panels or cabinets shall be mounted on metal frame supports independently of equipment. Control devices and metal enclosures shall be bolted or welded to steel channel or steel plate. All electrical equipment and devices not covered by the above, such as miscellaneous switches, thermostats, duct switches, temperature switches, floats, photoelectrical devices, and similar electrical devices shall be located and set as suitable for the application. Where control panels are provided as part of the equipment racks mounted on the floor, they shall be provided to support conduits and flexible connections to control panels.

3.2 COORDINATION

- A. Exact location of all electrical equipment, devices and fixtures shall be determined in field by contractor and verified by Engineer's field representative prior to installation.

END OF SECTION

SECTION 26 05 19

CABLE, WIRE AND CONNECTORS, 600 VOLT

PART 1 - GENERAL

1.1 WORK INCLUDED

- A. Building wire.
 - 1. Control system circuitry.
 - 2. Lighting circuitry.
 - 3. Other systems circuitry as designated.
- B. Cable.
- C. Wiring connections and terminations.
- D. Electrical/control portion of HVAC work covered by Division 23 pertaining to 600 volt cable, wire and connectors shall follow the requirements set forth by this specification.

1.2 REFERENCES

- A. NEMA WC 5 - Thermoplastic-Insulated Wire and Cable for the Transmission and Distribution of Electrical Energy.
- B. ANSI/UL 83 – Thermoplastic-Insulated Wire and Cables
- C. NFPA 70 – National Electrical Code, latest edition
- D. NEFA – Acceptance Testing Specifications for Electrical Power Distribution Equipment and Systems.
- E. Where application of National Electrical Code, trade association standards or publications appears to be in conflict with the requirements of this Section, the Architect/Engineer shall be asked for an interpretation.

1.3 SUBMITTALS

- A. Provide submittals in accordance with and in addition to Section 26 00 00, Basic Electrical Requirements, and Division 01 for submittal requirements.
- B. Submit manufacturer's literature and specification data sheets for each item of cable, wire and connectors.
- C. Qualification of cable and wire manufacturer: Company specializing in manufacturing products specified in this Section with minimum ten years experience.

1.4 DELIVERY, STORAGE AND HANDLING

- A. Provide factory-wrapped waterproof flexible barrier material for covering wire and cable wood reels, where applicable; and weather resistant fiberboard containers for factory packaging of cable, wire and connectors, to protect against physical damage in transit. Damaged cable, wire or connectors shall be removed from project site.
- B. Store cable, wire and connectors in a clean, dry indoor space in their factory-furnished coverings, which provides protection against the weather.

PART 2 - PRODUCTS

2.1 GENERAL REQUIREMENTS

- A. Generally, cable, wire and connectors shall be of manufacturer's standard materials, as indicated by published product information.
- B. Provide factory-fabricated wire of the size, rating, material and type as indicated for each service. Where not indicated, provide proper selection as required to comply with installation requirements and with NEC standards. The minimum size wire to be used for power or lighting circuits shall be #12 copper with insulation as noted below. Minimum size for control shall be #14 copper.
- C. The conductors of wires and cables shall be of copper (tinned where specified), and have conductivity in accordance with the standardization rules of the IEEE. The conductor and each strand shall be round and free of kinks and defects.
- D. Grounding conductors, where insulated, shall be colored solid green or identified with green color as required by the NEC. Conductors intended as a neutral shall be colored solid white, or identified as required by the NEC. All motor or equipment power wiring shall be colored according to Section 26 05 53, Electrical Identification.
- E. Use crimp type compression lugs for all wiring termination's, except on breakers or terminal strips in panel boards.

2.2 BUILDING WIRE

- A. Thermoplastic-insulated Building Wire: NEMA WC 5.
- B. Rubber-insulated Building Wire: NEMA WC 3.
- C. Feeders and Branch Circuits, all sizes: 98% conductivity copper, soft-drawn, stranded conductor, 600 volt insulation, THHN/THWN-2 Use XHHW-2 conductors where installed in conduit underground. Use of aluminum conductors is acceptable for conductors #1/0 and above. All conductor sizes shown on plans are based on copper cable. If aluminum conductor is selected, the contractor is responsible for sizing the conductor to match or exceed the equivalent capacity of the copper conductor. Conduit size shall also be adjusted to suit the aluminum conductors.

2.3 REMOTE CONTROL AND SIGNAL CABLE

- A. 600 Volt Insulation Control Cable for Class 1 Remote Control and Signal Circuits, Type TC:
 - 1. Individual Conductors: 14 AWG, stranded copper, XHHW insulation. Rated 90 degrees C dry, 75 degrees C wet, color-coded per ICEA Method 1 plus one green equipment grounding conductor.
 - 2. Assembly: Bundle wrapped with cable tape and covered with an overall PVC jacket. Cable shall pass IEEE-1202 vertical tray ribbon-burner flame test (210,000 BTU) VW-1.
- B. Instrumentation Cable
 - 1. 300 Volt Instrumentation Cable, Multiple Pairs, Overall Shield, Type PLTC:
 - a. Individual Conductors: 18 AWG, stranded, tinned copper, flame retardant polyethylene or PVC insulated, rated 105 degrees C, black and white numerically printed and coded pairs.
 - b. Assembly: Individual twisted pairs having a 100 percent coverage aluminum-polyester shield and 20 AWG stranded tinned copper drain wire. Conductor bundle shall be shielded with 100 percent coverage overall aluminum-polyester shield complete with 20 AWG drain wire. All group shields completely isolated from each other. Bundle wrapped with cable tape and covered with an overall flame retardant PVC jacket. Cable shall pass IEEE-383 vertical tray flame test (70,000 BTU) UL1581.
- C. Life Safety Systems Cable
 - 1. All life safety system wiring shall be installed in dedicated conduit or raceway with adequate separation/shielding from all other systems.

2. Life safety systems wiring shall be as specified in the Section 28 31 00 - Fire Alarm and Smoke Detection Systems.

D. Security/Access Control/CCTV Cable

1. All security/access control wiring shall be installed in dedicated conduits.
2. Security/access control wiring shall be rated and as specified below:

Circuit Type	No. of Conductors	Conductor Specifications	Cable Specifications
20 mA Current Loop	2	18-gauge, stranded copper	2 cables, 1 twisted pair each required
Card Reader Coaxial	--	18-gauge, solid copper, center conductor	Schlage Model No. SE9284PL or Anicom 5910PL
Contact Circuits	2	18-gauge, stranded copper	Nonshielded, twisted
CCTV Coaxial	--	--	Belden 89259 plenum rated, or approved equal

3. All security/access control power circuit wiring shall comply with paragraph 2.2. Building Wire of this Section.

- D. Plenum Cable for Class 3 Remote Control and Signal Circuits: 98% conductivity copper conductor, 300 volt insulation, rated 60 degree C, UL listed for use in air handling ducts, hollow spaces used as ducts, and plenums.

2.4 WIRING CONNECTIONS AND TERMINATIONS

- A. Provide factory-fabricated, metal connectors of the size, rating, material, type and class as indicated for each service. Where not indicated, provide proper selection as required to comply with installation requirements and with NEC standards. Select from only following types, classes, kinds and styles.

1. Type:
 - a. Solderless pressure connectors
 - b. Crimp.
 - c. Threaded.
 - d. Insulated spring wire connectors with plastic caps for 10 AWG and smaller.
2. Class: Insulated.
3. Material: Copper (for CU to CU connection).
4. Style:
 - a. Insulated terminals. Use ring-terminal for control wiring. Use flange (fork) spade compression terminal for termination of stranded conductors at wiring devices, including ground connection.
 - b. Split bolt-parallel connector.
 - c. Pigtail connector.
 - d. Pre-insulated multi-tap connector.

PART 3 - EXECUTION

3.1 INSPECTION

- A. Installer must examine the areas and conditions under which cable, wire and connectors are to be installed and notify the Contractor in writing of conditions detrimental to the proper and timely completion of the work. Inspect wire and cable for physical damage. Do not proceed with the work until unsatisfactory conditions have been corrected.

3.2 GENERAL WIRING METHODS

- A. Install electrical cable, wire and connectors as indicated, in accordance with the manufacturer's written instructions, the applicable requirements of NEC and the National Electrical Contractors Association's "Standard of Installation", and as required to ensure that products serve the intended functions.
- B. Coordinate cable and wire installation work with electrical raceway and equipment installation work, as necessary for proper interface. Do not install the conductors until raceway system is complete and properly cleaned.
- C. Cables shall be selected on the basis of their purpose and UL listing. Generally, use Types THWN-2 and THHN-2 in building interiors and other dry locations. Outdoors and underground in raceways, use Type XHHW-2. Conductors subject to abrasion, such as in lighting poles, shall be Type XHHW-2.
- D. No conductor smaller than No. 12 wire shall be used for lighting purposes. In the case of "home runs" over 50' in length (100' for 277 volt) no conductor smaller than a No. 10 wire shall be used. The sizing of all wire except remote control wire shall be accomplished in the case of both feeder and branch circuits by conforming to the following provisions. Separate neutral conductors shall be provided for each phase of the same size for 120V/277V single-phase application for heavy electrical loads, computer loads, loads fed from isolated transformers, lab equipment, clinic equipment, dedicated circuits, unless noted otherwise on drawings. Voltage drop on feeders and branch circuits shall not exceed NEC requirement.
- E. Remote control wires shall be no smaller than No. 14 conductors. Control wires shall be run in separate conduits. Departures from the sizes so determined shall be made only in those cases in which the National Electrical Code requires the use of larger conductors. The sizes as determined from these tables shall be regarded as the acceptable minimum under all other circumstances. In no case, however, shall there be a voltage drop greater than that specified in any feeder or branch circuit. The Contractor may, if he deems it necessary or advisable, use larger sized conductors than those shown. Under no circumstances, however, shall the Contractor use any conductors sized in a manner which does not conform to the above mentioned tables without having first secured the written approval of the Owner's duly authorized representative.
- F. Splice branch circuits only in accessible junction or outlet boxes. Control cable shall never be spliced except the final connection to field devices. Where terminations of cables that are installed under this Section are to be made by others, provide pigtail of adequate length for neat, trained and bundles connections, minimum 5 feet at each location, unless noted otherwise on drawings.
- G. Wiring Within An Enclosure: Contractor shall bundle ac and dc wiring separately within an enclosure. The Contractor shall utilize panel wire-ways when they are provided. Where wireways are not provided the Contractor shall neatly tag, bundle wires and secure to sub-panel at a minimum of every three inches with T&B Type TC5355 heavy duty mounting bases.
- H. Do not band any conductor either permanently or temporarily during installation to radii less than four times the outer diameter of 600-volt insulated conductors.

3.3 WIRING INSTALLATION IN RACEWAYS

- A. Wire and cable shall be pulled into clean dry conduit. Do not exceed manufacturer's recommended values for maximum pulling tension.

- B. Pull conductors together where more than one is being installed in a raceway.
- C. Use UL listed pulling compound or lubricant, when necessary; compound must not deteriorate conductor and insulation.
- D. Do not use a pulling means, including fish tape, cable or rope, which can damage the raceway.
- E. Install wire in raceway after interior of building has been physically protected from the weather and all mechanical work likely to injure conductors has been completed.
- F. Place an equal number of conductors for each phase of a circuit in same raceway.
- G. Provide separate conduit or raceway for line and load conductors of motor starters, safety disconnect switches, and similar devices. Those devices shall not share the same raceway.
- H. All conduits shall contain a green grounding conductor. Conduit, wireways, or boxes shall not be used as the equipment grounding conductor.

3.4 CABLE INSTALLATION

- A. Provide protection for exposed cables where subject to damage during construction. Do not install cable before the completion of raceway system.
- B. Cable above ceilings shall be in conduit or raceways. Cables, conduits and raceways shall not be laid on ceiling tiles or strapped to ceiling wire.
- C. Use suitable cable fittings and connectors.
- D. It shall be the Contractor's responsibility to accurately measure all cable runs before the cable is cut. The Contractor shall furnish all tools and equipment, have sufficient properly trained personnel and shall exercise necessary care to ensure that the cable is not damaged during installation. Cable found to be damaged before installation shall not be installed. Cable damage during installation shall be removed and replaced. Repairs to cables can only be done with written permission from the Owner's Representative and only under special circumstances.
- E. Care shall be exercised with cables entering or leaving cable trays that all cable bend radii shall not be less than the recommended minimum and that cables are not left to rest unprotected on any sharp edge or corner.
- F. PVC jacketed cable shall not be installed or worked in any way at temperatures below 32 degrees F, unless cable has been previously stored in a heated area 48 hours prior to being pulled and transported to a heated pulling area.
- G. Each cable entering an enclosure shall have its conductors bundled together and identified with the cable number. All groups of conductors within an enclosure shall be shaped and formed to provide a neat appearance to facilitate future additions or rework. All control conductors shall be numbered and shall be labeled at each termination with this number, using markers designed for the application.
- H. Multi-Conductor Cable Installation: Fire alarm cable shall be routed in a separate conduit only.
- I. Instrument Cable: Instrument cable shall, when conduit installation is required be installed in rigid steel conduit. They shall not be spliced at any point. The shields and drain wires of shielded signal cables shall be grounded only at one point as indicated on the Drawings.

3.5 WIRING CONNECTIONS AND TERMINATIONS

- A. Install splices, taps and terminations, which have equivalent-or-better mechanical strength and insulation as the conductor. Make splices, taps and terminations to carry full ampacity of conductors without perceptible temperature rise.
- B. Keep conductor splices and taps accessible and to a minimum, and in junction boxes only. Control circuit conductors shall terminate at terminal blocks only. Splices below grade shall only be in handholes or manholes and shall be made watertight with epoxy resin type splicing kits similar to Scotchcast.

- C. Use splice, tap and termination connectors, which are compatible with the conductor material.
- D. Thoroughly clean wires before installing lugs and connectors.
- E. Terminate spare conductors with electrical tape and label as spare.
- F. Power and Lighting Circuits: Use solderless pressure connectors with insulating covers for copper wire splices and taps, 8 AWG and larger. For 10 AWG and smaller, use insulated spring wire connectors with plastic caps on lighting and receptacle circuits.
- G. Use split bolt connectors for copper wire splices and taps, 6 AWG and larger. Tape un-insulated conductors and connectors with electrical tape to 150 percent of the insulation value of conductor.
- H. Connections for all wire sizes in motor terminal boxes where the motor leads are furnished with crimped-on lugs shall be made by installing ring type compression terminals on the motor branch circuit ends and then bolting the proper pairs of lugs together. First one layer of No. 33 scotch tape reversed (sticky side out), then a layer of rubber tape, then two layers of No. 33 half-lapped.
- I. Identify conductors per Section 26 05 53 - Electrical Identification.

3.6 FIELD QUALITY CONTROL

- A. Torque test conductor connections and terminations to manufacturer's recommended values.
- B. Perform continuity test on all power and equipment branch circuit conductors. Verify proper phasing connections.
- C. Conductors in vertical conduits or raceways shall be supported in the manner set forth in the appropriate section of the latest revision of the National Electrical Code. Lighting fixtures shall not be used for raceways for circuits other than parallel wiring of fixtures.
- D. Conductors may be run in parallel on sizes 1/0 to 500 MCM inclusive provided all paralleled conductors are the same size, length, and type of insulation. Except as otherwise shown on drawings, no more than three conductors may be run in parallel, and they shall be so arranged and terminated as to insure equal division of the total current between all conductors involved. Where parallel connection is contemplated, approval of the Owner's representative must be obtained before installation is made.

3.7 TESTING AND ACCEPTANCE

- A. Before final acceptance, the Contractor shall make voltage, insulation, and load tests, necessary to demonstrate to the Owner's representative the satisfactory installation and proper performance of all circuits.
- B. Test feeder conductors clear of faults. Insulation-resistance test shall be conducted per NETA – Acceptance Testing Specifications for Electrical Power Distribution Equipment and Systems. Test results below 50 megohms shall be cause for rejection of the wiring installation. Replace and retest all such rejected conductor.
- C. At the completion of this project, the Contractor shall provide for the Owner three (3) complete and finally corrected sets of working drawings. These sets of working drawings shall be new, unused and in good condition, and shall include the nature, destination, path, size and type of wire and all other characteristics for complete identification of each and every conduit and circuit.

END OF SECTION

SECTION 26 05 29

SECURING AND SUPPORTING METHODS

PART 1 - GENERAL

1.1 WORK INCLUDED

- A. Raceway, cable tray, and equipment supports
- B. Fastening hardware
- C. Coordinate location of concrete equipment pads

1.2 QUALITY ASSURANCE

- A. Support systems shall be adequate for weight of equipment and conduit, including wiring, which they carry. Support systems shall be sized adequately to support an additional 25% for future loads

1.3 COORDINATION

- A. Coordinate with other trades where conduit and cable tray supports are in the same location as piping, ductwork, and work of other trades and where supports are furnished and installed under other Divisions. Supporting from the work or supports of other Contractors shall not be allowed except by express, written permission of the Owner.

1.4 SUBMITTALS

- A. Provide submittals in accordance with and in addition to Section 26 00 00, Basic Electrical Requirements, and Division 01 for submittal requirement.

PART 2 - PRODUCTS

2.1 MATERIAL

- A. Support Channel:
 - 1. All non-corrosive locations: Hot-dip galvanized steel.
 - 2. Corrosive locations: Nonmetallic fiberglass.
- B. Hardware:
 - 1. All non-corrosive locations: Hot-dip galvanized steel.
 - 2. Corrosive locations: Stainless steel threaded rod, attachments and fasteners shall be used with fiberglass supports.
- C. Threaded Rod: used for rack support from structure above; 3/8-inch minimum diameter.

PART 3 - EXECUTION

3.1 INSTALLATION

- A. Fasten hanger rods, conduit clamps, and outlet and junction boxes to building structure using precast insert system, expansion anchors, or beam clamps. Do not use spring steel clips and clamps. Provide necessary calculations to select proper support materials for electrical equipment, raceway, and cable tray supports. Provide cable tray supports for cable tray filled to 125 percent capacity per NEC.
- B. Install hangers, anchors, sleeves and seals as indicated, in accordance with manufacturer's written instructions and with recognized industry practices to insure supporting devices comply with requirements. Comply with requirements of NEC for installation of supporting devices. Install supports with spacing in compliance with NEC requirements.

- C. Use toggle bolts or hollow wall fasteners in hollow masonry, plaster, or gypsum board partitions and walls; expansion anchors in solid masonry walls; or concrete surfaces; sheet metal screws in sheet metal studs; and wood screws in wood construction.
- D. Do not fasten supports to piping, ductwork, mechanical equipment, or conduit.
- E. Do not use powder actuated anchors without written permission from the Engineer.
- F. Do not drill structural steel members without written permission from the Structural Engineer.
- G. Fabricate supports from structural steel or steel channel, rigidly welded or bolted to present a neat appearance. Use hexagon head bolts with spring lock washers under all nuts.
- H. Bridge studs top and bottom with channels to support recessed mounted cabinets and panelboards in stud walls.
- I. Install surface mounted cabinets and panelboards with a minimum of four anchors. Provide strut channel supports to stand cabinet 1-5/8 inches off wall. Utilize "Post Bases" where support channel is attached to structural floor.
- J. Provide extra care in supporting PVC conduit to protect it from potential damage.
- K. Use fiberglass for nonmetallic raceway systems supports in areas subject to corrosives.
- L. All supports in contact with floor using stanchion type support shall be solidly bolted to the permanent structural floor.
- M. Conduit supports shall have at a minimum, the bottom support member constructed of double strut. This horizontal member shall be double-nutted, and the supporting all-thread rod shall be trimmed to one inch below lowest nut.
- N. Conduit entering/exiting cable tray shall be attached to the tray rail by means of unistrut bolted to the rail and standard manufacturer's accessories. Conduit shall only enter/exit tray horizontally supported within three feet of the tray, and extended into the tray two inches. Conduit shall be terminated with a grounding bushing, and bonded to the tray ground wire. (The attachment to the tray shall not be considered a support.)
- O. Coordinate with other electrical work, including raceway and wiring work, as necessary to interface installation of supporting devices with other work.
- P. Install freestanding electrical equipment on 4-inch concrete pads. Pad shall be a minimum four inches larger than equipment. No crevices shall be left around the pads. Equipment includes but not limited to the following:
 - 1. Motor Control Centers
 - 2. Static Transfer Switches
 - 3. Floor mounted VFDs
 - 4. Floor mounted transformers
 - 5. Switchboards, 1200A and larger
- Q. Do not anchor supports to columns. Where panelboards, cables, or conduits are routed on the face of a column provide "column hugging" channel supports.

3.2 TOUCH-UP

- A. Touch-up all scratches on securing and supporting system, and paint the ends of channel after cutting with an approved zinc chromate or 90 percent zinc paint.

END OF SECTION

SECTION 26 05 33

RACEWAYS, CONDUITS AND BOXES

PART 1 - GENERAL

1.1 WORK INCLUDED

A. Raceways:

1. Wireways.

B. Conduit:

1. Rigid metal conduit and fittings. (RGS)
2. Intermediate metal conduit and fittings. (IMC)
3. Electrical metallic tubing and fittings. (EMT)
4. Flexible metal conduit and fittings.
5. Liquid-tight flexible metal conduit and fittings.
6. Non-metallic conduit and fittings. (underground use only)
7. PVC coated rigid steel conduit.

C. Boxes:

1. Wall and ceiling outlet boxes.
2. Pull and junction boxes.

- D. Electrical/control portion of HVAC work covered by Division 23 pertaining raceway, conduit and boxes shall follow the requirement set forth by this specification.

1.2 REFERENCES

- A. NFPA 70 – National Electrical Code, latest edition
- B. ANSI C80.1 - Rigid Steel Conduit, Zinc-Coated
- C. ANSI C80.3 - Electrical Metallic Tubing, Zinc-Coated
- B. ANSI/NEMA FB 1 - Fittings and Supports for Conduit and Cable Assemblies
- E. EMA TC 3 - PVC Fittings for Use with Rigid PVC Conduit and Tubing
- F. ANSI/NEMA OS 1 - Sheet-Steel Outlet Boxes, Device Boxes, Covers and Box Supports
- G. NEMA 250 - Enclosures for Electrical Equipment (1000 Volts Maximum)
- H. ANSI/NEMA TC 2 – Electrical Plastic Tubing (EPT) and Conduit (EPC-40 and EPC-80)
- I. ANSI/UL 1 – Flexible Metal Conduit
- J. ANSI/UL 5 – Surface Metal Raceways and Fittings
- K. ANSI/UL 360 – Liquid-tight Flexible Steel Conduit
- L. ANSI/UL 467 – Electrical Grounding and Bonding Equipment
- M. ANSI/UL 651 – Schedule 40 and 80 Rigid PVC Conduit (underground use only)
- N. ANSI/UL 797 – Electrical Metal Tubing

- O. ANSI/UL 870 – Wireways, Auxiliary Gutters and Fittings
- P. NEMA RN 1 – Polyvinyl Chloride (PVC) Externally Coated galvanized Rigid Steel Conduit and Intermediate Metal Conduit
- Q. NEMA VE 1 – Metallic Cable Tray Systems
- R. UL 6 – Rigid Metal Conduit
- S. ANSI/UL 5C – Surface Raceways and Fittings for Use with Data, Signal, and Control Circuits
- T. ANSI/UL 498 – Attachment Plugs and Receptacles
- U. ANSI/UL 943 – Ground Fault Circuit Interrupters

1.3 SUBMITTALS

- A. Provide submittals in accordance with and in addition to Section 26 00 00, Basic Electrical Requirements, and Section 01330, Submittal Procedures.
- B. Shop drawings consisting of a complete list of equipment and materials, which will be used for the project, including manufacturer's descriptive and technical literature, catalog cuts and installation instructions.
- C. Sealing/fire stopping materials and details.

1.4 STORAGE AND HANDLING

- A. Handle materials carefully to avoid damage, breaking, denting and scoring. Damaged equipment or materials shall not be installed.
- B. Store materials in a clean dry space and protected from the weather.

PART 2 - PRODUCTS

2.1 WIREWAYS

- A. Wireways shall be of steel construction general purpose for indoor spaces and rain tight for outdoor applications with knockouts.
- B. Size shall be as indicated on Drawings.
- C. Cover shall be hinged or screw applied as indicated on Drawings. Rain tight wireways shall be provided with full gasketing.
- D. Fittings shall be so constructed to continue the "lay-in" feature through the entire installation.
- E. Provide all sheet metal parts with a rust inhibiting phosphating primer coating and finished in gray enamel. All hardware shall be cadmium plated to prevent corrosion.

2.2 CONDUIT AND FITTINGS

- A. Conduit and fittings for all electrical systems on this project shall include the following:
 - 1. Electrical power and lighting feeders
 - 2. Electrical power and lighting circuits
 - 3. Other electrical systems
- B. For each electrical wireway system indicated, provide a complete assembly of conduit, tubing or duct with fittings including, but not necessarily limited to, connectors, nipples, couplings, locknuts, bushings, expansion fittings, other components and accessories as needed to form a complete system of the same type indicated.
- C. Conduit fittings shall be designed and approved for the specific use intended. Conduit fittings, including flexible, shall have insulated throats or bushings. Rigid conduits shall have insulated bushings, unless grounding bushings are required by N.E.C. Article 250. Grounding bushings

shall have insulated throats.

- D. Rigid and intermediate metal conduit shall be hot-dipped galvanized. Fittings shall be threaded type. Expansion fittings shall be OZ Type DX.
- E. Electrical metallic tubing shall be galvanized. Fittings shall be all steel compression type. Expansion fittings shall be OZ Type TX.
- F. Flexible metal conduit and fittings shall be zinc-coated steel.
- G. Liquid-tight flexible conduit and fittings shall consist of single strip, continuous, flexible interlocked, double-wrapped steel, galvanized inside and outside, forming smooth internal wiring channel with liquid-tight covering of flexible polyvinyl chloride (PVC). It shall be furnished with a sealing O-ring where entering an enclosure subject to moisture. Where O-Rings are used, ground type bushings shall be used in the box or enclosure.
- H. Nonmetallic conduit and fittings shall be suitable for temperature rating of conductor but not less than 90°C. Nonmetallic conduit and fittings shall be molded of high impact PVC compound having noncombustible, nonmagnetic, non-corrosive and chemical resistant properties and shall be of the same manufacturer. Where located outdoors and above ground, the conduit and fittings shall be UV resistant. Solvent cement shall be of the same manufacturer as the conduit and shall be of the brush-on type. Spray solvents are prohibited. PVC coated metallic fittings shall not be permitted for PVC conduit connections.
- I. Crimp or set-screw type fittings are not acceptable.
- J. Minimum conduit size shall be 3/4 inch, except 1/2 inch flexible metallic conduit may be used as fixture whips.
- K. PVC coated rigid steel conduit shall be externally coated with a 40 mil PVC coating and internal phenolic coating over a galvanized surface.

2.3 PULL AND JUNCTION BOXES

- A. Boxes shall be galvanized sheet metal conforming to ANSI/NEMA OS 1 with screw-on cover and welded seams, stainless steel nuts, bolts, screws and washers.
- B. Boxes larger than 12 inches in any dimension shall be panelboard code gauze galvanized steel with hinged cover.
- C. Boxes shall be sized in accordance with NEC.

PART 3 - EXECUTION

3.1 INSTALLATION - CONDUIT

- A. Install products as indicated, in accordance with the applicable requirements of NEC, NEMA and the National Electrical Contractors Association's "Standard of Installation".
- B. Cut conduit square using a saw or pipe cutter. De-burr cut ends. Joints in steel conduit must be painted with T&B Kopr shield and drawn up tight. Threads for rigid metal conduit and IMC shall be deep and clean. Running threads shall not be used. Wipe plastic conduit clean and dry before joining. Apply full, even coat of cement with brush to entire area that will be inserted into fitting. Let joint cure for 20 minutes minimum. Spray type of cement is not acceptable. Install raceway and conduit system from point of origin in outlets shown, complete with support assemblies including all necessary hangers, beam clamps, hanger rods, turnbuckles, bracing, rolls, clips angles, through bolts, brackets, saddles, nuts, bolts, washers, offsets, pull boxes, junction boxes and fittings to ensure a complete functional raceway system. Where vertical drops of conduit are made to equipment in open space, the vertical conduit shall be rigidly supported from racks supported on the floor.
- C. Install rigid wall hot-dipped galvanized steel conduit or hot-dipped galvanized intermediate metal conduit for service entrance; feeders; wall or floor penetrations; mechanical rooms electrical rooms and exposed locations where there is a high potential subject to physical damage;

exposed outdoor locations; damp locations or any location as per design drawing. The following exceptions permitted:

1. EMT
 - a. In sizes up to and including 1-1/2 inch, may be used inside dry locations where not subject to mechanical damage. EMT may be used in air-conditioned spaces, such as accessible ceilings, dry wall partitions and exposed where 6 feet above the floor. EMT may not be used outside, in concrete, underground, in under floor spaces, in masonry walls, in locations likely to be damp, in electrical rooms subject to mechanical damage due to future installation, or exposed within 6 feet of the floor. EMT shall not be used for medium voltage circuits.
 - b. Where used for feeder circuits receptacle branch circuits and motor branch circuits EMT shall also contain a NEC grounding conductor.
 - c. All conduits shall be concealed in walls or ceilings unless otherwise noted.
2. Liquid-tight
 - a. Install liquid-tight flexible metal conduit for connections to rotating, vibrating, moving or movable equipment, including dry-type transformers. Install external ground wire on flexible conduit with grounding bushings. Maximum length shall be 6 feet minimum of 2 feet.
3. Flexible Metal Conduit
 - a. Install standard flexible metal conduit (not liquid-tight), which shall be only used for lighting fixture whips or motor vibrations, with internal ground wire. Install flexible conduit connection such that vibrations are not transmitted to adjoining conduit or building structure. Maximum length shall be 6 feet minimum of 3 feet; minimum size shall be 3/4; and minimum size shall be 1/2 inch for lay-in light fixture whips.
- D. Install conduits parallel and supported on Unistrut, or equal, trapezes and anchored with split ring hangers, conduit straps or other devices specifically designed for the purpose. No raceways or boxes shall be supported using wire. Arrange conduit to maintain headroom and present a neat appearance. Conduit routes shall follow the contour of the surface it is routed on. Route exposed conduit and tray above accessible ceilings parallel and perpendicular to walls and adjacent piping. Maintain 12-inch clearance between conduit and heat sources, such as flues, steam pipes, and heating appliances. Wire ties or "wrap lock" are not permitted to support or secure conduit system. Fasten conduit with the following material:
 1. Wood screws on wood
 2. Toggle bolts on hollow masonry
 3. Bolts and expansion anchors in concrete or brick
 4. Machine screws, threaded rods and clamps on steel
 5. Conduit clips on steel joists.
 6. 4 inch x 4 inch penta-treated pine installed in pitch pans on roof, spaced at intervals not to exceed 5 feet.
- E. Install conduits outside of building lines at a minimum depth of 30 inches below finished grade. Maintain twelve inches earth or two inches concrete separation between electrical conduits and other services or utilities underground. Encase all plastic service entrance conduits with concrete unless otherwise specifically detailed or noted on the drawings.
- F. Fittings shall be approved for grounding purposes or shall be jumpered with copper grounding conductors of appropriate ampacity. Leave termination of such jumpers exposed.

- G. Install expansion fittings in metal and PVC conduit as follows:
 - 1. Conduit Crossing Building Expansion Joints:
 - a. EMT all sizes
 - b. IMC all sizes
 - c. RMC all sizes
 - d. PVC all sizes
 - 2. Conduits entering environmental rooms and other locations subject to thermal expansion and as required by NEC.
 - 3. Unless expansion fitting has an integral bonding braid, as in Crouse-Hinds Type XC, a green insulated grounding conductor shall be pulled in the conduit. Both ends of this green grounding conductor shall be accessible for inspection.
 - H. Install conduit concealed in walls, partitions and above ceilings. Install conduit exposed in ceiling area (at structure) of boiler rooms, mechanical rooms and in other similar rooms where ceilings are not called for.
 - I. Avoid moisture traps where possible; where unavoidable, provide junction box with drain fitting at conduit low point.
 - J. Use suitable conduit caps to protect installed conduit against entrance of dirt and moisture if cable or wire are not installed immediately after conduit run. Tape covering conduit ends is not acceptable.
 - K. Provide 200 lb. nylon cord full length in empty conduit.
 - L. Where conduit penetrates fire-rated walls and floors, provide pipe sleeve two sizes larger than conduit; pack void around conduit with oakum and fill ends of sleeve with fire-resistive compound or provide mechanical fire-stop fittings with UL listed fire-rating or seal opening around conduit with UL listed foamed silicone elastomer compound equal to fire-rating of floor or wall.
 - M. Install no more than the equivalent of three 90-degree bends between boxes. Where four 90 degree bends are required, prior approval by the Engineer is required. Use conduit bodies to make sharp changes in direction, as around beams. Conduit bodies shall be readily accessible and sized for the cables installed. Running or rolling offsets are not approved. Use factory long radius elbows for bends in conduit larger than 2-inch size. All parallel bends shall be concentric.
 - N. Nylon pull string shall be provided full length in conduit designated for future use.
- 3.2 INSTALLATION - WIREWAYS
- A. Bolt wireways to steel channels fastened to the wall or in self-supporting structure. Install level.
 - B. Gasket each joint in oil-tight wireway.
 - C. Mount rain tight wireway for exterior installation in horizontal position only.
- 3.3 INSTALLATION - BOXES
- A. Provide electrical boxes as shown on Drawings, and as required for splices, taps, wire pulling, equipment connections, and code compliance.
 - B. Provide outlet box accessories as required for each installation, including mounting brackets, wallboard hangers, extension rings, fixture studs, cable clamps and metal straps for supporting outlet boxes, compatible with outlet boxes being used and meeting requirements of individual situations.
 - C. Electrical box locations shown on Contract Drawings are approximate unless dimensioned. Verify location of outlets prior to rough-in.

- D. Locate and install boxes to allow access, minimum 12 inches above ceiling except where space dimensions do not allow.
 - E. Do not install boxes back-to-back in walls. Provide minimum 6-inch separation. Provide minimum 24-inch separation in acoustic-rated walls. If boxes are connected together, install flexible connection between the two and pack openings with fiberglass.
 - F. Secure boxes rigidly to the substrate upon which they are being mounted, or solidly imbed boxes in concrete or masonry. Do not support junction boxes from the raceway systems. Boxes shall not be permitted to move laterally. Boxes shall be secured between two studs. Boxes connected to one stud are not permitted.
 - G. Provide knockout plugs for unused openings.
 - H. Use multiple-gang boxes where more than one device is mounted together. Do not use sectional boxes. Provide barriers to separate wiring of different voltage systems.
 - I. Install boxes in walls without damaging wall insulation.
 - J. Outlet boxes in plaster partitions shall be "shallow-type" set flush in wall so there is at least 5/8 inch plaster covering back of box.
 - K. Outlet boxes for switch shall not be used as junction boxes.
 - L. Coordinate mounting heights and locations of outlets mounted above counters, benches and backsplashes.
 - M. In inaccessible ceiling areas, position outlets and junction boxes within 6 inches of recessed luminaire, to be accessible through luminaire ceiling opening.
 - N. Outlet boxes supporting fixtures shall be securely anchored in place in an approved manner. Support outlet boxes and fixtures in acoustic ceiling areas from building structures, not from acoustic ceilings. Lighting fixture outlets shall be coordinated with mechanical and architectural equipment and elements to eliminate conflicts and provide a workable neat installation.
 - O. Set floor boxes level and flush with finish flooring material.
 - P. Provide tamper resistance receptacles in child care areas, psychiatric, and medical facilities.
- 3.4 WALL AND FLOOR PENETRATIONS:
- A. Core drilling shall be approved in writing by the Structural Engineer prior to execution.
 - C. Provide a 4 inch curb around block outs through concrete floors. Fire-stop all openings per Architectural specification.
 - D. Route conduit through roof openings for piping and ductwork where possible; otherwise, route through roof jack with pitch pocket. Coordinate roof penetrations with the roofing contractor.

END OF SECTION

SECTION 26 05 53

ELECTRICAL IDENTIFICATION

PART 1 - GENERAL

1.1 WORK INCLUDED

- A. Nameplates and tape labels
- B. Wire and cable markers
- C. Conduit color coding and labeling

1.2 REFERENCES

- A. NFPA 70 – National Electrical Code (latest edition)

1.3 SUBMITTALS

- A. Provide submittals in accordance with and in addition to Section 26 00 00, Basic Electrical Requirements, and Division 01 for submittal requirement.
 - 1. Furnish nameplate identification schedules listing equipment type and nameplate data with letter sizes and nameplate material.

PART 2 - PRODUCTS

2.1 MATERIALS

- A. Equipment Nameplates:
 - 1. For normal power electrical equipment, provide engraved three-layer laminated plastic nameplates, engraved white letters on a black background.
 - 2. For emergency equipment provide engraved three-layer laminated plastic nameplates with engraved white letters on a red background.
 - 3. For UPS powered equipment provide engraved three-layer laminated plastic nameplates with engraved white letters on an orange background.
 - 4. For fire alarm system provide engraved three-layer laminated plastic nameplates with white letters on a yellow background.
- C. Conductor Color Tape and Heat Shrink:
 - 1. Colored vinyl electrical tape shall be applied perpendicular to the long dimension of the cable or conductor.
 - 2. In applications utilizing tray cable, heat shrinkable tubing shall be used to obtain the proper color coding for the length of the conductor in the cabinet or enclosure. Variations to the cable color coding due to standard types of wire or cables are not acceptable.
- D. Conduit Labels (5 kV and 15 kV Conduits Only): 2-inch black letters on yellow background reading "DANGER - 12,470 VOLTS" or "DANGER - 4,160 VOLTS". Labels shall have adhesive backing, and shall be installed at intervals not exceeding 50 feet and on all pull boxes located to be visible from floor.
- E. Warning labels: Provide warning labels with black lettering on red background with a minimum of 1/2" lettering.
- F. Tape Labels: Embossed adhesive tape, with minimum 1/4-inch letters for labeling receptacles, switches, control device stations, junction and pull boxes and manual motor starter units, etc.
 - 1. White letters on black background for normal power.

- 2. White letters on red background for emergency/standby power.
- 3. White letters on orange background for UPS power.
- G. J-Box and Cover plate Voltage Labels: Black stenciled letters 1/4" high. Adhesive back tapes may be used if a clear tape is applied over the label for protection.

PART 3 - EXECUTION

3.1 INSTALLATION

- A. Degrease and clean surfaces to receive nameplates or tape labels.
- B. Install nameplates parallel to equipment lines.
- C. Secure plastic nameplates to equipment fronts using screws or rivets. Use of adhesives shall be per Owner's approval. Secure nameplate to outside face of flush mounted panelboard doors in finished locations.

3.2 WIRE IDENTIFICATION

- A. Provide wire markers on each conductor in panelboard gutters, pull boxes, outlet and junction boxes, and at load connection. Identify with branch circuit or feeder number for power and lighting circuits. Label control wire with number as indicated on schematic and interconnection diagrams or equipment manufacturer's shop drawings for control wiring.
- B. Conductors for power circuits to be identified per the following schedule.

Conductor	System Voltage		
	480/277V	208/120V	
Phase A	Brown	Black	
Phase B	Purple	Red	
Phase C	Yellow	Blue	
Neutral	Gray	White	
Grounding IG	Green N/A	Green Green w/Yellow	

3.3 NAMEPLATE ENGRAVING SCHEDULE

- A. Provide nameplates of minimum letter height as scheduled below. Nameplates shall be same as equipment names indicated on the Drawings.
- B. Individual Circuit Breakers in Distribution Panelboards, Disconnect Switches, Motor Starters, and Contactors: 1/4-inch; identify source to device and the load it serves, including location.
- C. Dry Type Transformers Not in Substations: 3/8-inch; identify equipment designation. 1/4-inch; identify primary and secondary voltages, primary source, and secondary load and location.
- D. Automatic Transfer Switches: 3/8-inch; white letters and red background; identify equipment designation 1/4-inch; identify voltage rating, normal source, standby source and load served including location.
- E. Panelboards: 3/8-inch; identify equipment designation. 1/4 -inch; identify source, voltage and bus rating.

3.4 ENCLOSURE COLOR CODING

- A. The following systems shall have each junction and pull box cover completely painted per the following:

System	Color of Box Cover
Telecommunications	Brown
DDC	Blue
Emergency Power	Red
Security	White
Fire Alarm	Yellow
UPS	Orange

END OF SECTION

SECTION 26 51 00

INTERIOR LIGHTING

PART 1 - GENERAL

1.1 WORK INCLUDED

- A. Interior lighting fixtures and accessories
- B. Emergency lighting units
- C. Emergency exit signs
- D. Emergency fluorescent lamp power supplies
- E. Lamps
- F. Ballasts
- G. Lighting controls

1.2 REFERENCES

- A. NEPA 101 - Code for Safety to Life from Fire in Buildings and Structures
- B. NEMA WD1 - General-Purpose Wiring Devices
- C. ANSI C82.1 - Specification for Fluorescent Lamp Ballasts
- D. ANSI C82.4 - Specifications for High-Intensity-Discharge Lamp Ballasts (Multiple Supply Type)
- E. NEMA LE - H-I-D Lighting System Noise Criterion (LS-NC) Ratings
- F. UL 844 - Electric Lighting Fixtures for Use in hazardous (classified) Locations
- G. UL 924 - Emergency Lighting and Power Equipment
- H. UL 935 - Fluorescent-Lamp Ballasts
- I. UL 1029 - High-Intensity-Discharge Lamp Ballasts
- J. UL 1572 - High Intensity Discharge Lighting Fixtures
- K. UL 1574 – Track Lighting Systems
- L. IESNA – Lighting Handbook
- M. NEMA WD 1 - General Color Requirements for Wiring devices
- N. NEMA LE 5B – Procedure for Determine Luminaire Efficacy Ratings for High-Intensity Discharge Industrial Luminaires
- O. NFPA 70 – National Electrical Code
- P. ASHRAE/IES 90.1 – Energy Standard for Buildings Except Low-Rise Residential Buildings
- Q. Standards For State-Funded Outdoor Lighting Fixture – Texas House Bill 916 (1999)
- R. UT System OFPC – Security Planning and Design Guidelines (2002 release)

1.3 DESIGN CRITERIA

- A. Lighting level design shall be per IESNA (Illuminating Engineering Society of North America) recommendation.
- B. The power consumption for interior and exterior lighting shall not exceed power allowance as per ASHRAE 90.1 latest revision.

1.4 SUBMITTALS

- A. Provide submittals in accordance with and in addition to Section 26 00 00, Basic Electrical Requirements, and Division 1 for submittal requirement.
- B. Submit manufacturer's data on interior and exterior lighting fixtures in booklet form, with separate sheet for each fixture, assembled by luminaire "type" in alphabetical order, with the proposed fixture and accessories clearly labeled.
- C. Submit dimensioned drawings and performance data including complete photometric test data for each luminaire, candlepower distribution curves in two or more planes, candlepower chart zero to 90 degrees, lumen output zonal summary chart, average and maximum brightness data, and coefficients of utilization for zonal cavity calculations, spacing to mounting height ratio, efficiency and visual comfort probability. Also provide luminaire weights, mounting data, and accessory information for each luminaire type.
- D. Lamps: Catalog cuts showing voltages, colors, approximate hours life, approximate initial lumens, lumen maintenance curve, lamp type and base.
- E. Ballasts: Catalog cuts showing type, wiring diagram, nominal watts, input voltage, starting current, input watts, sound rating, power factor and low temperature characteristics.
- F. Controls: Catalog cuts and/or shop drawings showing dimensions, voltage capacity, contact ratings, wiring diagrams, operating levels, and temperature ratings.
- G. Lighting design shall be in compliance with power allowance for lighting, which is stipulated by ASHRAE 90.1. Compliance forms along with engineering data associated with it shall be submitted for Owner's review during design phase.

1.5 PRODUCT DELIVERY, STORAGE AND HANDLING

- A. Deliver lighting fixtures individually wrapped in factory-fabricated fiberboard type containers. Parabolic louvers shall be shipped in thermally sealed polyethylene wrapper.
- B. Handle lighting fixtures carefully to prevent breakage, denting and scoring the fixture finish. Do not install damaged lighting fixtures.
- C. Store lighting fixtures in a clean, dry space and protected from the weather.

PART 2 - PRODUCTS

2.1 GENERAL

- A. Lighting fixtures and accessories shall comply with the design and function requirements of the project. Design characteristics shall be as noted in manufacturer's submittal data.
- B. Provide lighting fixtures of the size, type and rating as scheduled, complete with, but not limited to, lamps, lamp holders, reflectors, ballasts, poles and wiring.

2.2 INTERIOR LIGHTING FIXTURES

- A. Fluorescent Fixtures
 - 1. See plans for light fixture schedule.
- B. Incandescent fixtures shall be pre-wired equipped with integral thermal protection. Use incandescent only where aesthetics outweighs economic considerations.
- C. Lighting track shall be surface mount or pendant mount per the requirement on drawings, by manufacturer of track mounted light fixtures.
- D. High Bay, Low Bay HID Fixtures
 - 1. Provide rugged, lightweight, cast aluminum ballast housing with a baked electro-coat paint finish.

2. Optic reflector shall be fully fluted, anodized aluminum providing high efficiency. Where enclosed and gasketed type fixtures are specified, provide luminaires designed for continuous operation in an ambient temperature of 55° C.

E. Lamp Holders or Sockets

4. Lamp holders and sockets shall be provided with minimum 18 AWG wiring leads.

F. Reflector Finishes

1. Painted Finishes: Provide electro-statically applied dry polyester white powder coat finish with minimum reflectance of 88 percent on all light reflecting surfaces.
2. Specular/Semispecular Finishes: Provide Alzak-type anodized finish on aluminum louvers and reflectors as specified in Luminaire Schedule as shown on the drawings. Minimum reflectivity shall be:
 - a. Specular: 80 percent
 - b. Semi-specular: 75 percent

G. UL Listing

1. All Luminaires and components shall be UL tested, listed, and labeled.
2. Luminaires installed under canopies, roofs, or similar damp or wet locations shall be UL listed and labeled as suitable for damp or wet locations.
3. Recessed luminaires installed in fire rated ceilings and using a fire rated protective cover shall be thermally protected for this application and shall be approved for the installation in a fire-rated ceiling.

2.7 BALLASTS

A. Acceptable Manufacturers

1. Valmont
2. Advance
3. Magnetek
4. Other manufacturers equal in design and function will be considered upon A/E approval following substitution procedure in 26 00 00, and Division 1 for substitution requirement.

PART 3 - EXECUTION

3.1 INSPECTION

- A. Prior to order lighting fixture, check the building electrical system requirements, architectural finishes, and the type of ceilings that lighting fixture will be installed. Any discrepancies of compatibility pertaining trim, frames, color, mounting, ballast, voltage and etc. shall be brought to the attention of A/E by written notice. Do not proceed with procurement until discrepancies are resolved in a satisfactory manner.
- B. Installer shall examine the areas and conditions that light fixtures are to be installed and notify the Contractor in writing of conditions detrimental to the proper and timely completion of the work. Do not proceed with the work until unsatisfactory conditions have been corrected.

3.2 INSTALLATION OF LIGHTING FIXTURES

- A. Install light fixtures in accordance with the manufacturer's written instructions, the applicable requirements of NEC and national and local code, standard, and regulations. Install lamps in accordance with manufacturer's instructions.

- B. Install luminaries at locations as shown on the Drawings; install aligned, aimed, and leveled. Install fixtures in accordance with manufacturer's installation instructions complete with mounting accessories, trim and support materials. Fasten fixtures securely to structural support members of the building; solid pendant fixtures shall be plumb.
- C. Coordinate with other crafts to avoid conflicts between luminaires, supports, fittings and mechanical equipment.
- H. Lighting Fixtures Adjustment
 - 1. Adjust to illuminate intended areas as directed.
 - 2. Adjust exterior fixtures during hours of darkness.
- I. Immediately before final observation, clean all fixtures, inside and out, including plastics and glassware, and adjust all trim to properly fit adjacent surface, replace broken or damaged parts, and lamp and test all fixtures for electrical as well as mechanical operation.
- J. Protect installed fixtures from damage during the remainder of the construction period.
- K. Upon completion of installation of interior lighting fixtures, and after circuitry has been energized, apply electrical energy to demonstrate capability and compliance with requirements. When possible, correct malfunctioning units at the site, then retest to demonstrate compliance; otherwise, remove and replace with new units, and proceed with retesting.
- L. Incandescent lamps shall be new at time of final acceptance. Fluorescent lamps may be used in the final finishing of the building. Those that have exceeded more than 1/3 of their rated life (as established by Construction Inspector records), or that have blackened ends or inoperable shall be replaced with new lamps before final acceptance.
- M. Lamp Disposal
 - 1. The procedure of disposal of lamps that are mercury containing shall follow the guideline set by EPA (definitions in Title 40 Code of Federal Regulations 261 Subpart C, January 2000).

END OF SECTION

SECTION 28 31 00 - ADDRESSABLE DEVICE FIRE ALARM SYSTEM

PART 1 - GENERAL

1.1 RELATED DOCUMENTS:

- A. The Conditions of the Contract and applicable requirements of Division 1, "General Requirements" and Section 26 00 00, "Basic Electrical Requirements", govern this Section.

1.2 DESCRIPTION OF WORK:

- A. General: The extent of fire alarm system work is as shown and scheduled and includes, but is not limited to, providing a system with the following functions and operations:
1. Provide new fire alarm devices fully installed wired and interfaced to the existing addressable device fire alarm system in the building. All devices, fire alarm system materials, wiring and installation methods shall match the existing fire alarm system installation in the building.
 2. Provide labor and software programming to upgrade the graphic annunciation of UCT at the remote UTPD monitoring station. Coordinate integration of work with UTPD.
 3. All fire alarm system final connections and interfaces to the existing fire alarm system shall be made by Grinnell, the building fire alarm system installer.
 4. All smoke detectors need to be labeled with the point number on the exterior of the device.
 5. All pullstations need to be keyed to CAT 30.
 6. Upon completion of the fire alarm installation updated CAD files need to be submitted to the owner.

1.3 STANDARDS:

- A. Products shall be designed, manufactured, tested, and installed in compliance with the latest edition of the following standards:
1. National Fire Protection Association Standards including NFPA 72-2002, as applicable.
 2. Underwriters' Laboratories, Inc. Requirements and Listing for use in Fire Protective Signaling Systems as applicable.
 3. The requirements of State Fire Marshal and local authorities having jurisdiction.
 4. Comply with requirements of the Americans with Disabilities Act of 1990.

1.4 QUALITY ASSURANCE:

- A. Manufacturers: All fire alarm system equipment shall match the original building fire alarm system manufacturer to assure compatibility.
- B. UL and FM-listing: All fire alarm system components shall be UL and FM listed for fire alarm use. The UL listing shall be under category UOJZ to assure that the entire system has been tested as an integral life safety system.
- C. All equipment furnished shall be the current standard products of a single manufacturer and shall bear the label of the Underwriters' Laboratories for use in fire alarm system designed in compliance with the requirements of NFPA codes. Raceways, wiring and terminations shall be accomplished in compliance with the requirements of the National Electric Code, Article 760, except that all wiring shall be in EMT or an approved raceway.

- D. The system as installed shall, upon completion, be certified by a state licensed fire alarm installation superintendent to the Owner as being installed in compliance with the specification, the requirements of all state and local codes, and as being operational and free from defects.
- E. All system equipment supplied shall be listed by the Underwriters' Laboratories for NFPA 72 system use, and all applicable NFPA Codes.
- F. The installing contractor shall be authorized and designated representative of the fire alarm system manufacturer to sell, install and service the manufacturer's equipment and shall stock the required spare parts to keep the system in operation. The installing contractor shall maintain a staff of specialists for technical assistance and system maintenance.
- G. The installing contractor must be licensed by the State Fire Marshal to sell, install, and service fire alarm system as required by Article 5.43-2 of the Texas Insurance Code.
- H. The installing contractor shall have on his staff a minimum of five installation superintendents who are licensed by the State Fire Marshal's office for such purpose and under whose supervision installation, final connections and check out will take place, as required by the Texas Insurance Code.
- I. The installing contractor or equipment supplier shall have a staff a minimum of one certified NICET Level II state licensed fire alarm planner under whose supervision system design shall take place. In lieu of a NICET-certified state licensed fire alarm planner, the contractor or supplier may provide design supervision with a graduate or professional electrical engineer.
- J. The equipment supplier shall provide 24 hour, 365 days per year emergency service with qualified and state-licensed service technicians.
- K. The installing contractor shall have been actively engaged in the business of selling, installing, and servicing microprocessor and multiplex fire alarm systems for at least 8 years and shall have proof of experience in the installation and maintenance of the type of fire alarm system specified herein.
- L. The manufacturer or his representative shall maintain within 50 miles of the installation, a staff of factory trained, state licensed fire technicians, together with all support parts necessary for maintenance of the system.
- M. Where approved in writing by the system manufacturer and installing contractor, the Electrical Contractor may install all conduit and boxes. The system wiring shall be pulled in by the installing contractor. All system connections, device installation, system start-up and testing shall be performed by the installing contractor. Rough-in by the electrical contractor shall not in any way affect the system manufacturer's and installing contractor's full responsibility for the installed fire alarm system.
- N. The manufacturer shall submit legal documentation indicating that the purchased fire alarm equipment will be provided with parts, and support for 10 years after the acceptance by the Owner.
- O. Plenum cables are not acceptable. All wiring shall be listed for limited energy fire alarm use and rated for 300 volts minimum and installed in a suitable conduit or raceway.
- P. The complete combination fire alarm system shall comply with the requirements of the Texas State Fire Marshall. Modifications required to provide compliance shall be made at no cost to the Owner. Where Contract Document requirements are in excess of Code requirements are permitted under the Code, the Contract Documents shall govern.

1.5 SUBMITTALS:

- A. Shop Drawings submittals shall include, but not be limited to, the following:
 - 1. A block diagram showing system components, wire runs, wire counts and wire sizes.

2. Manufacturer's descriptive literature for all panels, modules and peripheral equipment describing size, color, finish, capacity and electrical characteristics.
3. Completely identified and marked catalog cuts of all associated equipment and devices, with all non applicable items crossed out, or applicable devices clearly highlighted and/or identified.
4. Complete and detailed point-to-point wiring diagrams for all devices in the system.
5. Complete Bill of Material for all equipment.
6. A copy of the form to be used for final tests, 100% audit and checkout shall be submitted for approval.
7. Additional information as required in Section 26 00 00.

1.6 DELIVERY, STORAGE AND HANDLING:

- A. Deliver fire alarm system components in factory-fabricated containers.
- B. Store in a clean, dry space and protect from the weather.
- C. Handle fire alarm system components carefully to avoid damage to material components, enclosure and finish.

PART 2 - PRODUCTS

2.1 MATERIALS AND COMPONENTS:

- A. General: Provide the required fire alarm system products in the sizes and capacities required or indicated, complying with the manufacturer's published product information of standard materials and components, designed and constructed for the applications indicated.

2.2 SYSTEM OPERATION:

- A. General: System operation for new fire alarm devices shall match existing operation.
- B. Smoke Detectors: Activation of an "intelligent" smoke detector shall cause the same operations as for similar existing devices connected to the fire alarm system.
- C. Addressable Devices: Activation of any addressable manual pull station, sprinkler waterflow switch or "intelligent" heat detector shall cause the same operations as for similar existing devices connected to the fire alarm system.
- D. Valve Supervisory Switches: Closure of a supervised OS&Y valve sensed via a supervisory switch or loss of supervisory air pressure in a dry-pipe sprinkler system, sensed via a pressure switch shall cause the following operations and indications:
 1. The system common alarm LED on the Fire Alarm Control Panel shall flash. The internal audible trouble device shall sound. Acknowledging the alarm condition shall silence the audible trouble device and revert the flashing common alarm LED to a steady state.
 2. An alpha-numeric LCD Display shall indicate all applicable information associated with the alarm condition including: zone, device type, device location, and time of alarm. Location and zoning messages shall be custom field-programmed to respective premises.
 3. Appropriate status change message(s) shall be transmitted to all graphics terminals, CRT displays, and printers.
- E. System Wiring Supervision: Supervision of new fire alarm wiring shall match existing fire alarm system wiring supervision.

2.3 SYSTEM DEVICES:

- A. General: System devices shall be located as shown on the Drawings. The Contractor shall refer to all the drawings to determine where devices are to be located. All system devices shall be numbered with a unique number. The numbering system shall include the building area, type of device, and device number. This numbering system shall be shown on each submitted floor plan drawing, fire alarm riser diagram and be tabulated. The tabulation shall be included in each O&M Manual submitted to the Owner.

2.4 SYSTEM ZONING:

- A. General: The system shall employ "intelligent" smoke detectors and addressable interface devices capable of being recognized and annunciated at the main control panel and CRT terminals on an individual basis. All devices shall be field-programmed into software zones for the purpose of general area identification and annunciation. However, each device shall also be annunciate identified on an individual basis including exact location and device type. All zoning/device location information shall be totally field-programmable to exact job requirements. Devices shall be zoned as follows:
1. Area smoke detectors shall be zoned by floor.
- B. Initiating and monitored devices shall include, but not be limited to, the following:
1. Ceiling smoke detectors.
 2. Addressable manual pull stations with firefighters telephone jacks.
 3. Addressable input/output devices.
- C. The system shall utilize remote transponder panels for distributed voice communications, firefighters' telephone conventional zoned initiating circuits and auxiliary control output circuits. Remote transponder panels shall communicate with the main CPU via the SLC data loop and be capable of being intermixed on the same loop as intelligent heat and smoke detection and control modules.
- D. Output devices shall include, but not be limited to, the following:
1. Wall and ceiling alarm speakers/visual signals.
 2. Addressable interface relays.

2.5 FIRE ALARM SYSTEM CENTRAL EQUIPMENT:

- A. General: The Fire Alarm Control Panel and equipment is existing and shall be reused.

2.6 REMOTE TRANSPONDER PANELS:

- A. General: Provide new transponder panels as required to interface new initiating and output devices to the existing fire alarm system.
- B. Remote transponder/control panels shall be distributed remotely throughout the facility as required and as indicated on the Drawings. Transponders shall provide input/output interface between all field devices/equipment and main system CPU.
- C. All functions of the transponder unit(s) shall be field-programmable via the main system CPU and incorporate nonvolatile RAM memory. Each unit shall be capable of operating independently in default mode should communication with the main CPU be disrupted. Transponders shall be capable of operating on the system SLC intelligent loop in conjunction with intelligent field devices.
- D. The transponder shall include a resident microprocessor based CPU control module interfacing the main system CPU with respective I/O modules served by the resident/local CPU. The local CPU shall provide each transponder with common status indicators, pilot/status LED, common alarm LED,

and common trouble LED. Each CPU module shall include local silence, reset, trouble display, lamp test, and reset capability. Each control module shall provide dual Form C common alarm and trouble contacts as well as a local alarm/trouble Piezo sounder.

- E. Each transponder shall be capable of providing audio power supervision/annunciation, power supply supervision/annunciation, and supervision of all associated I/O modules. Each transponder shall be field programmable for alarm verification. Selection of alarm verification shall provide each associated zone/ input module with the automatic ability to verify all smoke detector initiated alarm signals before initiating any event initiated output functions. The system shall have the ability to electronically differentiate between smoke detector alarms and contact/shorting device alarms and will NOT allow the verification sequence to occur from signals initiated from pull stations, flow switches, heat sensors, etc.
- F. All transponder mapping/addressing shall be accomplished via the transponder CPU module.
- G. Transponders shall be provided with zone initiation input modules as required. Each module shall provide eight Style B or four Style D initiating zone circuits. Each zone shall be capable of intermixing two-wire smoke detectors and contact type devices on the same circuit. Each zone shall assume a designated and distinct address I.D. within the system. The transponder shall monitor the status of each zone module and zone circuit for normal, alarm and trouble, and report any status or change thereof to the main system control panel/CPU. Each zone shall be equipped with status and trouble LED indication. Each zone shall be field programmable for alarm, waterflow, supervisory, or non-alarm/status configuration. Each zone shall be capable of being programmed/mapped in software to activate selected output functions.
- H. Transponders shall be provided with zone alarm output modules as required. Each module shall provide eight Style Y indicating appliance circuits. Each indicating circuit shall be capable of being field programmed as conventional alarm, audio, and/or telephone circuits. Output circuits shall be power limited. Each output zone shall assume a designated and distinct address I.D. within the system and be field programmable for control by event actuation. The transponder shall monitor the status of each alarm output module and each associated circuit for normal, activation, and trouble, and report any status or change thereof to the main system control panel/CPU. Each zone shall be equipped with a status and trouble LED indicator.
- I. Each alarm output circuit/zone shall be field programmable for silenceable or non-silenceable operation. Specified control circuits shall be supervised via alarm output circuits and shall be programmed for non-silenceable operation.
- J. Transponders shall be provided with auxiliary output/control relay modules as required. Each module shall provide eight SPDT (or four DPDT) field programmable output circuits. Output circuits shall be power limited. Each output shall be rated at 2 amps, 24 volts dc. Each circuit shall assume a designated and distinct address I.D. within the system and be field programmable for control by event actuation. Designated control circuits shall be provided with software assignable manual control switch as herein specified. The transponder shall monitor the status of each output module and associated circuit for normal, activated, and trouble conditions. Each circuit shall be equipped with an individual status LED indicator.
- K. The power supply for the panel and all fire alarm peripherals shall be integral to the control panel. The power supply shall provide all control panel and peripheral power needs with filtered power as well as 3.5 amperes of unregulated 24 volt dc power for external audio/visual devices. The audio/visual power may be increased as needed by adding additional modular expansion power supplies. All power supplies shall be designed to meet UL and NFPA requirements for power-limited operation on all external signaling lines, including initiating circuits and indicating circuits. All circuitry shall be UL listed for power-limited application.
- L. Input power shall be 120 volt ac, 60 Hz. The power supply shall provide internal supervised batteries and automatic charger. The power supply shall provide both positive and negative ground fault supervision, battery/charger fail condition, ac power fail indicators.

- M. Transponder shall be housed in key-locked steel cabinet painted in baked enamel finish. Cabinet door shall provide transparent glass window for viewing transponder indicators and controls. The cabinets shall be no more than 5" deep and 24" wide to conserve space. Cabinets shall be provided with conduit knockouts on sides and top for versatility in installation. The cabinet(s) shall be capable of accommodating multiple transponder units in a single enclosure.

2.7 SMOKE SENSORS/DETECTORS:

- A. Intelligent "Ceiling-mounted" Photoelectric Smoke Sensors: Autocall or approved equal analog photoelectric smoke sensors shall be provided where indicated on the Drawings.
1. The intelligent photoelectric smoke sensors shall connect via two wires to one of the intelligent control panel loops.
 2. The sensors shall use the photoelectric principal to measure smoke density and shall, on command from the control panel, send data to the panel representing the analog level of smoke density.
 3. The sensors/control panel shall provide automatic sensitivity "drift" compensation to provide longer term stability and reliability. The sensor shall also provide a "maintenance alert" feature whereby the detector shall initiate a trouble condition should the units sensitivity approach the outside limits of the normal sensitivity window.
 4. The sensor shall be provided with extensive RF and EMF noise reduction circuitry.
 5. The sensor shall employ sophisticated self-compensating solid state LED light source and photosensitive circuitry.
 6. The sensor/control panel shall provide a calibrated test method whereby they will simulate an alarm condition and report that condition to the control panel. Such a test may be initiated at the detector itself, by activating a magnetic test switch, or may be activated remotely on command from the control panel.
 7. The sensors shall provide address-setting means on the sensor head using rotary decimal switches. No binary coding shall be required. The sensors shall also store an internal identification code which the control panel shall use to identify the type of sensor.
 8. The sensors shall provide dual alarm and power/status LEDs. Status LEDs shall flash under normal conditions, indicating that the sensor is operational and in regular communication with the control panel. Both LEDs may be placed into steady illumination by the control panel, indicating that an alarm condition has been detected and verified. An output connection shall be provided in the base for connecting an external remote alarm LED.
 9. The sensor shall be semiflush ceiling-mounted and be provided with modular detector head with twist-lock base. Sensors shall also be suitable for surface-mounting below the raised floor or above the ceiling. Sensors shall be provided in smooth attractive white finish, and sealed against dirt, vermin, and back pressure. Sensors shall be provided with fine mesh insect/contaminate screen.
 10. Sensors shall be UL listed with respective control panel.

2.8 MANUAL STATIONS:

- A. Addressable Manual Stations : Thorn Autocall or approved equal manual stations with addressable interface module or an approved equal shall be provided where indicated on the Drawings.
1. Manual stations in stairwells and in unfinished area shall be constructed of white high impact molded Lexan with instructions for station operation in raised red letters. Stations shall have

- an integral firefighters' telephone jack installed in the side of the station. Stations shall be installed using standard semiflush mounting.
2. The manual station addressable module shall connect with two wires to one of the intelligent control panel loops.
 3. The addressable module at the manual station shall, on command from the control panel, send data to the panel representing the state of the manual switch.
 4. The manual station addressable module shall provide address-setting means using rotary decimal switches and shall also store an internal identification code which the control panel shall use to identify the type of device. No binary coding shall be required.
- 2.9 FIRE FIGHTER PHONE JACKS: Provide fire fighters phone jacks where shown on the drawings. Provide stainless with graphics to match existing building jacks.
- 2.10 INPUT/OUTPUT DEVICES:
- A. Monitor Module (Addressable input Device): Thorn Autocall or approved equal addressable monitor modules shall be provided where required to interface to contact alarm devices.
1. The monitor module shall be used to connect a supervised zone of conventional initiating devices (any N.O. dry contact device, including 4-wire smoke detectors) to an intelligent loop.
 2. The monitor module will mount in a 4" square electrical box.
 3. The monitor module shall provide address-setting means using rotary decimal switches and shall also store an internal identification code which the control panel shall use to identify the type of device. No binary coding shall be required.
- B. Control Module (Addressable Output Device): Thorn Autocall or approved equal control/relay modules shall be provided where required to provide audible alarm interface and/or relay control interface.
1. The control module shall be used to connect a supervised zone of conventional indicating devices (any 24 volt polarized audiovisual indicating appliance) to an intelligent loop. The zone may be wired Class A or Class B field-selected. The control module may be optionally-wired as dry contact (Form C) relay.
 2. The control module will mount in a standard 4" electrical box.
 3. Power for the relay actuation shall be provided by the intelligent detector loop to reduce wiring connection requirements. Audio/visual power shall be provided by a separate loop from the main control panel or from supervised remote power supplies.
 4. The control module shall provide address-setting means using rotary decimal switches and shall also store an internal identification code which the control panel shall use to identify the type of device. No binary coding shall be required. A status LED shall be provided which shall flash under normal conditions, indicating that the control module is operational and in regular communication with the control panel. The LED shall illuminate steady when the device is actuated via the Fire Alarm Control Panel.
- C. Auxiliary Control Relays: Air Products, Thorn Autocall or approved equal relays shall be provided for control interface. Relays shall be heavy duty type and rated up to 20 amps at 120 volts ac, 60 Hz. Relays shall be provided with NEMA 1 dust cover assembly and be provided with DPDT contacts.
- D. Sprinkler Waterflow and Pressure Switches: Switches shall be furnished and installed under Division 15, with wiring and addressable input device interface by this Contractor.

- E. Fire Protection OS&Y Valve Supervisory Switches: Switches shall be furnished and installed under Division 15, with wiring and addressable input device interface by this Contractor. Switches shall activate a supervisory signal within two turns of the valve or more than 1/3 of the valve travel toward the closed position.
- F. Dry-pipe and Pre-action Sprinkler Low Air Pressure Trouble Signals: Low pressure switches and system trouble dry contacts shall be furnished and installed under Division 15, with wiring and addressable input device interface by this Contractor.

2.11 ALARM SIGNAL DEVICES:

- A. Ceiling Mounted Fire Alarm Speakers: Wheelock "E" Series or equal flush mounted fire alarm speakers which match existing devices used in the building shall be provided. Ceiling mounted fire alarm speakers shall have a white finish.
- B. Wall Mounted Fire Alarm Speakers/Visual Signals: Wheelock "E" Series or equal recess/surface mounted fire alarm speakers with integral visual signals which match existing devices used in the building shall be provided. Wall mounted fire alarm speaker/visual signals shall have a white finish. Visual signal candela ratings shall be in compliance with applicable codes and standards.
- C. Wall Mounted Fire Alarm Visual Signals: Wheelock "E" Series or equal recess/surface mounted fire alarm visual signals which match existing devices used in the building shall be provided. Wall mounted fire alarm visual signals shall have a white finish. Visual signal candela ratings shall be in compliance with applicable codes and standards.

2.12 SYSTEM WIRING:

- A. The equipment supplier shall furnish to the installing contractor a complete detailed point-to-point wiring diagram showing the system equipment and required number, type and sizes of conductors and conduit sizes. Where common devices which break the alarm circuit are installed on a common zone with shorting type device, the circuit breaking devices shall be wired electrically downstream of the shorting type devices.
- B. All fire alarm system wiring shall be installed in an approved raceway.
- C. All fire alarm system wiring shall be multiconductor, UL listed FPL for limited energy (300 volt) and fire alarm applications, and NEC approved fire alarm cable. Wiring shall be installed in accordance with NEC, Article 760 of NFPA Standard 70 and manufacturer's recommendations. All wiring shall be copper and installed in conduit sized in accordance with the National Electrical Code.
- D. Fire alarm system wiring shall be color coded.
- E. All fire alarm system junction boxes including covers, shall be secured, painted red and marked in white lettering as specified in Section 26 05 53.
- F. Wire size shall be determined by calculated voltage drop and circuit loading. Minimum wire size shall be as follows:
 - 1. #18 AWG twisted and shielded for data and communications circuits.
 - 2. #18 AWG for non-data and communications initiating and low voltage auxiliary control circuits.
 - 3. #16 AWG twisted for alarm circuits.
 - 4. #14 AWG for all power circuits.

PART 3 - EXECUTION

3.1 GENERAL:

- A. Inspection: Installer shall examine the areas and conditions under which the fire alarm system is to be installed and notify the Contractor in writing of conditions detrimental to the proper and timely completion of the work. Do not proceed until unsatisfactory conditions have been corrected.
- B. NECA: All fire alarm installations shall be in accordance with NECA 305-2001, Standard for Fire Alarm System Job Practices.

3.2 SYSTEM DESIGN:

- A. General: The basic equipment and device locations have been shown on the contract drawings. Specific wiring between equipment/devices has not been shown. It is the contractors responsibility to submit for approval the COMPLETE ENGINEERED system configuration and layout showing all devices, wiring, conduit, and locations along with other required information as specified herein.

3.3 PROGRAMMING:

- A. General: The fire alarm system installer shall provide programming to interface new fire alarm devices as required.

3.4 INSTALLATION:

- A. General: Install system and materials in accordance with manufacturer's instructions, roughing-in drawings, and details on the Drawings. Install electrical work and use electrical products complying with the requirements of the applicable Division 26 sections of these Specifications. Mount manual stations and alarm devices at heights specified in Section 26 05 00, "Basic Electrical Material and Method".
- B. Wiring: All wiring shall be in accordance with NFPA 72, the National Electrical Code, Local Codes, and Article 760 of NFPA Standard 70. All wiring sizes shall conform to recommendations of the equipment manufacturer, and as indicated on the engineered shop drawings.
 - 1. Install fire alarm system line voltage and low-voltage wiring in a suitable raceway. Conceal fire alarm system conduit except in mechanical rooms and areas where other conduit and piping are exposed. Fasten flexible conductors, which bridge cabinets and doors, neatly along hinge side and protect against abrasion. Tie and support the conductors neatly.
 - 2. All wiring shall be run in a supervised fashion (i.e. no branch wiring or dog-legged wiring) per NFPA requirements such that any wiring disarrangement will initiate the appropriate trouble signals via the main control panel per NFPA and UL requirements. Intelligent SLC loops may be T-tapped/branch wired due to inherent dynamic supervision.
 - 3. Wiring splices shall be kept to a minimum with required splices to be made in designated terminal boxes or at field device junction boxes. Transposing or color code changes of wiring will not be permitted. End-of-line supervisory devices shall be installed with the last device on the respective circuit. Said device shall be appropriately marked designating it as the terminating device on the respective circuit.
 - 4. No AC wiring or any other wiring shall be run in the same conduit as fire alarm wiring.
 - 5. Number code and color code conductors appropriately and permanently for future identification and servicing of the system.
- C. Conduit/Raceway: All wire shall be installed in an approved conduit/raceway system. Maximum conduit "fill" shall not exceed 40% per NEC.
 - 1. Conduit and raceway system shall be installed as specified other Sections of the Specifications.

2. Minimum conduit size shall be 3/4" EMT. Install conduit per engineered shop drawings. Minimum conduit size shall be 3/4" EMT. Install conduit per engineered shop drawings. Conduit and raceway system shall be installed as specified under the general electrical sections of the specifications and per NEC. Maximum conduit "fill" shall not exceed 40% per NEC.
- D. Labeling: All system controls, indicators and other devices shall be labeled with names, designations and operating instructions as applicable. Labels shall be either engraved nameplates or covered printed labels and shall be approved by the Engineer. All water flow switches which are hidden shall have identification points. These identification points shall be red tags with white lettering indicating location of the water flow switch. Tag location will be visible from corridors.
- E. Checkout: Check wiring to ensure that wiring is in accordance with the system manufacturer's wiring diagrams and that the system is free of open circuits, short circuits, and grounds.
- F. Identification: Refer to Section 26 05 53 for additional requirements concerning painting, nameplates, and labeling.

3.5 COORDINATION:

- A. It shall be the responsibility of the installing contractor to coordinate all requirements surrounding installation of the fire alarm system with all trades. Adequate coordination shall be provided to ensure proper installation and interface to all peripheral items required to interact with the fire alarm to provide a complete and functional life safety system.
- B. The installing contractor shall be fully responsible for coordinating all system and device messages and system operation with the Owner's Representatives and Operating Personnel.

3.6 SYSTEM CHECKOUT AND TEST:

- A. All final control panel connections shall be made by a state licensed, factory-trained technical representative of the manufacturer and who shall supervise a System Checkout and Test to demonstrate and confirm to the Engineer, Owner's Representative and the fire department, that the fire alarm system is 100% operational upon completion of the installation, and that it complies with all local code requirements and these specifications. It is intended that the System Checkout and Test be followed by a continuing program of inspection testing and maintenance. The Contractor shall provide a proposal to the Owner for a Maintenance, Inspection and Quarterly Testing Contract in compliance with NFPA 72H, upon completion and system checkout.
- B. The System Checkout and Test shall be performed within 30 days after the fire alarm installation and all peripheral systems are completed. The System Checkout and Test shall be performed by a minimum of two licensed fire alarm system technicians, one of which is licensed by the State of Texas, and acceptable to the Engineer and the authority having jurisdiction. The test shall be performed in two parts and two-way radios for use by the test observers shall be provided. The first part shall be a full dry-run test with all subcontractors present, but without the Owner's Representative or fire department present. After the dry-run test is successfully completed, then the final test with the Owner's Representative and fire department present shall be performed.
- C. This Contractor shall coordinate the test schedule with all necessary parties and subcontractors required to be present for a complete and functional test.
- D. The System Checkout and Test which is a comprehensive 100% inspection and test of all fire alarm system equipment and shall include, but not be limited to the following:
 1. Fire Alarm Control Equipment:
 - a. A visual and functional test of all fire alarm control and auxiliary control equipment.
 - b. A visual inspection shall be conducted to establish that all electrical connections and equipment as required are properly installed and operating.

- c. A remote functional fault simulation test shall be conducted on all relevant field wiring terminations to ensure that all wiring is properly supervised as required.
 - d. All indicators shall be tested to ensure proper function and operation.
 - e. All device messages shall be verified to be correct, as installed.
 - f. All system auxiliary functions including, but not limited to, CPU reporting, elevator recall, fire/ smoke door and shutter control, security interface, HVAC equipment control and shutdown, smoke control initiation, and other specified control functions shall be functionally tested to verify proper operation and proper system messages.
 - g. Control panel supervisory and alarm current readings shall be taken to verify that the control panel has the appropriate power supplies and standby batteries to operate the system as required. A 3 minute general alarm stress test both under ac power and standby power shall be conducted to further ensure complete operation of the system.
 - h. The Voice Communication System shall be visually and functionally tested to verify proper operation. Voice paging zoning shall be verified and automatic and manual operation of the voice paging system shall be fully verified. Self-monitoring functions of the voice paging system shall be verified.
 - i. The Firefighters' Telephone System shall be functionally tested to verify proper zoning, supervision and operation of each firefighters' telephone jack location.
2. Annunciators: All annunciators shall be tested to ensure that each point activates properly and labeling correctly defines the area of alarm.
 3. Fire Alarm Peripheral Devices: All fire alarm peripheral devices shall be functionally tested and the location and testing information recorded for each device.
 4. Initiating Devices (Manual and Automatic):
 - a. All manual and automatic initiating devices shall be inspected to ensure proper placement and mounting as recommended by the manufacturer and as indicated in these specifications.
 - b. All manual fire alarm stations and all automatic initiating devices (smoke detectors, heat detectors, waterflow switches, etc.) shall be functionally tested for alarm operation.
 - c. A minimum of 10% of initiating devices shall be functionally tested for proper wiring supervision. Failure of any tested device on any zone shall require that all devices in that zone shall be tested for supervision.
 - d. All device messages shall be verified to be correct as installed.
 5. Alarm Signaling Devices:
 - a. All visual alarm indicators and exit sign flashing shall be functionally tested to ensure proper operation and that they are clearly visible.
 - b. Alarm signaling devices shall be field-checked and tested for proper operation and output.
 - c. Decibel reading shall be taken to ensure that the alarm signal level can be clearly heard in all areas of the facility, if required by the authority having jurisdiction. Additional devices may be required to provide adequate sound penetration (or as required by the local authority having jurisdiction). Contractor shall provide a unit price for such devices should they be required.
 - d. A minimum of 10% of the alarm signaling device shall be functionally tested for proper wiring supervision.

6. Reporting:

- a. Upon completion of the 100% System Checkout and Test, four copies of the final report shall be documented, certified, and sent to the Engineer for distribution to the Owner or authorized Owner's Representative indicating that all fire alarm equipment has been tested and is 100% operational.
- b. The final report shall be generated by the equipment manufacturers headquarters or authorized representative to ensure integrity and uniformity of all testing procedures and reporting. The report shall contain the testing information, stating the precise location and operational status of each and every peripheral device and shall include a Fire Alarm System Certification and Description Document per NFPA 72.
- c. The 100% System Checkout and Test shall be performed by factory-trained representatives, and one of the individuals shall possess a state license for fire alarm installation supervision.

3.7 OPERATING AND MAINTENANCE DATA:

- A. The system manufacturer shall submit fire alarm system Operating & Maintenance (O&M) Manuals with complete system documentation including test reports and record drawings.
- B. The manufacturer's authorized representative shall instruct the Owner's designated employees in the proper operation of the system and all required periodic maintenance. This instruction will include three copies of a written summary in booklet or binder form so employees can retain for future reference. Basic operating instructions for the system shall be framed and mounted at the main control unit.

3.8 WARRANTY:

- A. The fire alarm and security systems shall be warranted against defects in workmanship and materials, under normal use and service, for a period of one year from the date of acceptance by the Owner. Any equipment shown to be defective shall be repaired, replaced or adjusted free of charge.
- B. The warranty period shall begin after successful completion of the Owner's inspections and tests. In the event of any system malfunctions or nuisance alarms, the Contractor will take appropriate corrective action. This action may necessitate a repeat of the response test if the Owner so desires. Continued improper performance during warranty shall be cause to require the Contractor to remove the system.
- C. The warranty start date will not begin until after a period of 30 consecutive days of system operation without any nuisance alarms caused by malfunctioning of hardware or software.

END OF SECTION 28 31 00

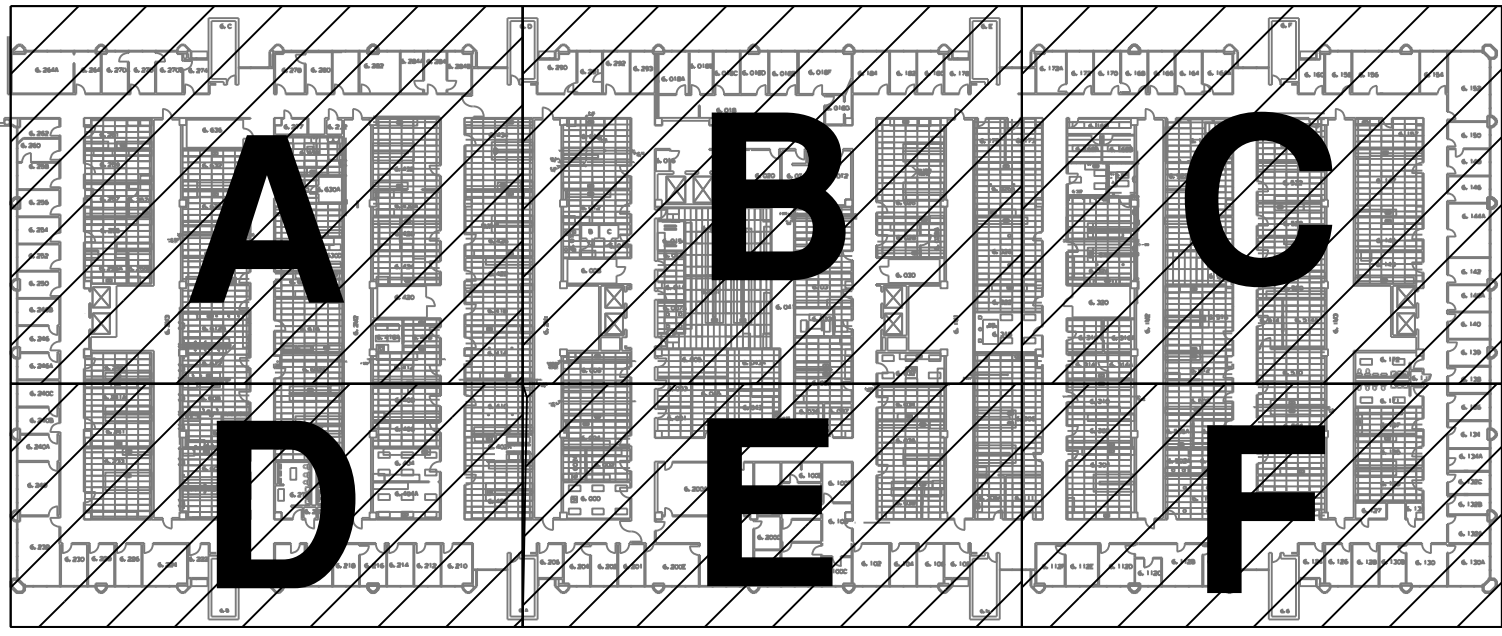
ABBREVIATIONS	LIGHTING/SWITCHES	GENERAL NOTES ELECTRICAL	DUCTWORK	GENERAL NOTES MECHANICAL																																																								
<p>A AMPS, AIR (COMPRESSED) A/C AIR CONDITIONING</p> <p>AHU AIR HANDLING UNIT AL ALUMINUM ALT ALTERNATE AMB AMBIENT APD AIR PRESSURE DROP ARCH ARCHITECT, ARCHITECTURAL ASHRAE AMERICAN SOCIETY OF HEATING AND REFRIGERATION AND AIR CONDITIONING ENGINEERS</p> <p>ASME AMERICAN SOCIETY OF MECHANICAL ENGINEERS ASTM AMERICAN SOCIETY FOR TESTING AND MATERIALS AUTO AUTOMATIC AUX AUXILIARY AVG AVERAGE C CELSIUS, CONDUIT CFM CUBIC FEET PER MINUTE CU FT CUBIC FEET DB DRY BULB DBL DOUBLE DC DIRECT CURRENT, DOUBLE DUCT CONSTANT VOLUME DEG DEGREE DIA DIAMETER DIM DIMENSION DISC DISCONNECT DIST DISTRIBUTION DN DOWN</p> <p>EAT ENTERING AIR TEMPERATURE EDB ENTERING DRY BULB ENGR ENGINEER EQUIP EQUIPMENT EQUIV EQUIVALENT EWB ENTERING WET BULB EXH EXHAUST EXIST EXISTING EXT EXTERNAL F FAHRENHEIT, FAN, FIRE, FEMALE FIXT FIXTURE FLEX FLEXIBLE FLR FLOOR FT FOOT, FEET GA GAGE GALV GALVANIZED HT HEIGHT HVAC HEATING, VENTILATING & AIR CONDITIONING</p> <p>ID INSIDE DIAMETER IN INCH JB JUNCTION BOX L LENGTH, LONG, LAVATORY</p> <p>LBS(S) POUND(S) LDB LEAVING DRY BULB LVL LEVEL LWB LEAVING WET BULB M MALE, MEN MAX MAXIMUM MBH THOUSANDS OF BTU'S MC MECHANICAL CONTRACTOR MECH MECHANICAL M/E/P MECHANICAL/ ELECTRICAL/ PLUMBING</p> <p>MIN MINIMUM MISC MISCELLANEOUS MU MAKE-UP N NORTH, NITROGEN (N) NEW NC NOISE CRITERIA NO NUMBER OA OUTSIDE AIR OD OUTSIDE DIAMETER OFF OFFICE OH OVERHEAD OPNG OPENING PD PRESSURE DROP PRES PRESSURE (R) RELOCATE RA RETURN AIR RCP REFLECTED CEILING PLAN S SOUTH, SUPPLY, SINK SA SUPPLY AIR, SHOP AIR, SOUND ATTENUATOR SECT SECTION SF SQUARE FEET SP STATIC PRESSURE, SUMP PUMP</p> <p>SPEC SPECIFICATION, SPECIFIED SQ IN SQUARE INCHES SST STAINLESS STEEL STD STANDARD T STAT THERMOSTAT/SENSOR TC TEMPERATURE CONTROL W WATT, WIDTH, WASTE, WEST, WIRE, WOMEN W/ WITH W/O WITHOUT WB WET BULB</p>	<p>ⓐ ⓑ NEW CAM LIGHTING FIXTURE, LETTER DENOTES TYPE, H PREFIX DENOTES HID</p> <p>ⓐ RELOCATED EXISTING CAM FIXTURE, LETTER DENOTES TYPE WHERE APPLICABLE</p> <p>ⓐ EXISTING CAM LIGHTING FIXTURE TO REMAIN</p> <p>* EXISTING CAM LIGHTING FIXTURE TO BE REMOVED AND REUSED AS APPLICABLE</p> <p>ⓐ X NEW EXIT SIGN, ARROWS AS INDICATED, LETTER DENOTES TYPE</p> <p>ⓐ R RELOCATED EXISTING EXIT SIGN, ARROWS AS INDICATED</p> <p>ⓐ EXISTING EXIT SIGN TO REMAIN, ARROWS AS INDICATED</p> <p>ⓐ R EXISTING EXIT SIGN TO BE REMOVED AND REUSED AS APPLICABLE</p> <p>▭ FB NEW LIGHTING FIXTURE, LETTER DENOTES TYPE, F PREFIX DENOTES FLUORESCENT</p> <p>▭ FB RELOCATED EXISTING LIGHT FIXTURE, LETTER DENOTES TYPE WHERE APPLICABLE</p> <p>▭ FB EXISTING LIGHT FIXTURE TO REMAIN</p> <p>▭ FB EXISTING LIGHT FIXTURE TO BE REMOVED AND REUSED AS APPLICABLE</p> <p>● LIGHT FIXTURE ON EMERGENCY CIRCUIT</p> <p>Ⓢ NEW SWITCH, SPST, 20A, 120/277V</p> <p>Ⓢ R RELOCATED EXISTING SWITCH</p> <p>Ⓢ EXISTING SWITCH TO REMAIN</p> <p>Ⓢ R EXISTING SWITCH TO BE REMOVED AND REUSED AS APPLICABLE</p> <p>Ⓢ 3 SWITCH, 20A, 120/277V, *2' DENOTES DPST, *3' DENOTES THREE-WAY, *4' DENOTES FOUR-WAY</p> <p>Ⓢ L SWITCH, SPDT, CENTER OFF, MOMENTARY CONTACT, *L' DENOTES TOGGLE, *LR' DENOTES ROCKER</p> <p>Ⓢ K SWITCH, SPST, 20A, 120/277V, *K' DENOTES KEY SWITCH, *P' DENOTES PILOT LIGHT, *T' DENOTES SPRING WOUND TIMER, *M' DENOTES MOTION DETECTOR</p> <p>Ⓢ DIMMER CONTROL SWITCH, 1000 WATT UNLESS OTHERWISE NOTED</p> <p>FIRE ALARM</p> <p>AV FIRE ALARM AUDIO VISUAL SIGNAL, WALL MOUNTED</p> <p>V FIRE ALARM VISUAL SIGNAL, WALL MOUNTED</p> <p>A FIRE ALARM AUDIO SIGNAL, WALL MOUNTED</p> <p>Ⓐ FIRE ALARM CEILING SPEAKER</p> <p>Ⓢ FIRE ALARM CEILING VISUAL</p> <p>Ⓢ AREA SMOKE DETECTOR</p> <p>Ⓢ A AREA SMOKE DETECTOR ALARM</p> <p>FIRE PROTECTION SPRINKLER</p> <p>Ⓢ SPRINKLER HEAD</p> <p>GENERAL NOTES ELECTRICAL</p> <p>LIGHTING FIXTURE CIRCUITING NOTES:</p> <p>A. THE LIGHTING PLANS INDICATE SWITCHING AND BRANCH CIRCUIT NUMBERS FOR ALL LIGHTING FIXTURES. LOWER CASE LETTERS AT SWITCHES AND LIGHT FIXTURES INDICATE SWITCHING WHERE THE CONTROL PATTERN IS NOT OBVIOUS. INSTALL BRANCH CIRCUIT WIRING IN A RACEWAY TO ALL RIGIDLY ATTACHED LIGHT FIXTURES AND TO JUNCTION BOXES FOR ALL LAY-IN LIGHT FIXTURES, AS REQUIRED TO PROVIDE SWITCHING AND CIRCUITING AS SHOWN ON THE DRAWINGS. RE: SPECIFICATIONS FOR ADDITIONAL REQUIREMENTS.</p> <p>B. BRANCH CIRCUIT HOMERUNS SHALL BE LIMITED TO THREE PHASE CONDUCTORS (ON DIFFERENT PHASES), ONE NEUTRAL CONDUCTOR PER PHASE AND ONE GROUND CONDUCTOR (WHERE SHOWN OR SPECIFIED), AND SHALL BE INSTALLED IN CONDUIT.</p> <p>C. ALL LAY-IN LIGHTING FIXTURES SHALL BE CONNECTED TO A BRANCH CIRCUIT JUNCTION BOX WITH A FLEXIBLE FIXTURE TAIL, RE: SPECIFICATIONS. A MAXIMUM OF FOUR FIXTURE TAILS SHALL BE CONNECTED TO A SINGLE JUNCTION BOX. FIXTURE TO FIXTURE WIRING OF LAY-IN LIGHTING FIXTURES IS NOT PERMITTED.</p>	<p>A. ALL ELECTRICAL WORK SHALL COMPLY WITH APPLICABLE STATE & LOCAL BUILDING CODES & REQUIREMENTS.</p> <p>B. REFER TO THE SPECS FOR MATERIALS & METHODS FOR ELECTRICAL CONSTRUCTION.</p> <p>C. REFER TO THE SPECS FOR SUBMITTAL REQUIREMENTS.</p> <p>D. THE ELECTRICAL CONTRACTOR SHALL VISIT THE SITE & FAMILIARIZE THEMSELV WITH EXISTING CONDITIONS WHICH WILL IMPACT CONSTRUCTION OF THIS PROJECT, PRIOR TO SUBMITTING BIDS.</p> <p>E. ALL INTERRUPTIONS TO UTILITY SERVICES & ALL WORK IN OCCUPIED SPACES SHALL BE SCHEDULED WITH THE BUILDING MANAGER AT LEAST 3 WEEKS IN ADVANCE & SHALL BE PERFORMED AT TIMES WHICH ARE ACCEPTABLE TO THE BUILDING MANAGER.</p> <p>F. RE: ARCHITECTURAL REFLECTED CEILING PLANS FOR THE EXACT LOCATION OF ALL CEILING MOUNTED DEVICES.</p> <p>G. RE: ARCHITECTURAL INTERIOR ELEVATIONS, IF PROVIDED FOR LOCATIONS OF WALL MOUNTED DEVICES.</p> <p>H. FURNISH ACCESS DOORS FOR INSTALLATION BY THE GENERAL CONTRACTOR WHERE ACCESS IS REQUIRED TO CONCEALED ELECTRICAL EQUIPMENT.</p> <p>I. ALL REQUIRED HVAC CONTROL WIRING & EQUIPMENT SHALL BE PROVIDED BY THE MECHANICAL CONTRACTOR.</p> <p>J. ALL WIRING SHALL BE MINIMUM 2*12, *12G, 3/4" C, UNLESS NOTED OR SHOWN ON THE DRAWINGS OTHERWISE. REFER TO SPECIFICATIONS FOR REQUIREMENTS TO INCREASE WIRE SIZE FOR DISTANCES OVER 50 FEET FOR 120 VOLT AND 100 FEET FOR 277 VOLT. UNDER NO CIRCUMSTANCES SHALL THE VOLTAGE DROP BE WORSE THAN 3% FOR ANY BRANCH CIRCUIT AND 2% FOR ANY FEEDER.</p> <p>K. COORDINATE ALL SLAB PENETRATIONS WITH THE EXISTING STRUCTURE AND OBTAIN WRITTEN APPROVAL FROM THE OWNER PRIOR TO CORE DRILLING. ALL RATED PARTITION PENETRATIONS SHALL BE SEALED WITH A UL-LISTED FIRE SAFING SYSTEM, IN ACCORDANCE WITH APPLICABLE STATE AND LOCAL REQUIREMENTS.</p> <p>L. CONTRACTOR SHALL SUBMIT RECORD DRAWINGS AND O&M MANUALS AS REQUIRED IN ASHRAE 90.1-2010 SECTION 8.7. THIS REQUIREMENT SHALL BE IN ADDITION TO RECORD DRAWINGS AS REQUIRED IN THE SPECIFICATIONS.</p> <p>M. MULTI-OUTLET RACEWAY SHALL INCLUDE FACTORY ENTRANCE FITTINGS, COUPLINGS, ELBOWS, END CAPS, BRACKETS, COVERS AND BASE AS REQUIRED TO BE INSTALLED AS A COMPLETE SYSTEM.</p> <p>N. THE MINIMUM CONDUIT SIZE ALLOWED IS 3/4", EXCEPT 3/8" PRE-MANUFACTURED FIXTURE WHIPS WITH A GROUND WIRE MAYBE USED FOR CONNECTION TO LIGHT FIXTURES.</p> <p>O. ALL PANEL DIRECTORIES SHALL BE TYPED. LIST UNUSED BREAKERS AS SPARE. LIST AVAILABLE SPACES AS SPACE.</p> <p>P. CIRCUITS FROM DIFFERENT SOURCES SHALL NOT OCCUPY THE SAME RACEWAY, 120/208V AND 277/480 VOLT CIRCUITS SHALL NOT OCCUPY THE SAME RACEWAY. NORMAL AND EMERGENCY POWER SHALL NOT OCCUPY THE SAME RACEWAY.</p> <p>Q. CONTROL CIRCUITS OPERATING AT 50 VOLTS OR LESS SHALL NOT OCCUPY THE SAME CONDUIT AS CIRCUITS OPERATING AT GREATER THAN 50 VOLTS.</p> <p>R. ALL ELECTRICAL EQUIPMENT SHALL BE LISTED AND LABELED FOR INSTALLATION PER RECOGNIZED ELECTRICAL TESTING LABORATORIES.</p> <p>S. PROVIDE SEPERATE NEUTRALS FOR ALL BRANCH CIRCUITS. SHARED NEUTRALS ARE NOT ALLOWED.</p>	<p>☒ SUPPLY AIR SLOT, NO LETTER DENOTES NEW, *R' DENOTES RELOCATED EXISTING.</p> <p>☒ EXISTING SUPPLY AIR DIFFUSER, NO LETTER DENOTES TO REMAIN, *R' DENOTES TO BE REMOVED AND REUSED AS APPLICABLE.</p> <p>☒ RETURN AIR OR EXHAUST GRILL, NO LETTER DENOTES NEW, *R' DENOTES RELOCATED EXISTING.</p> <p>☒ EXISTING RETURN AIR OR EXHAUST GRILL, NO LETTER DENOTES TO REMAIN, *R' DENOTES TO BE REMOVED AND REUSED AS APPLICABLE.</p> <p>▭ SUPPLY AIR SLOT, NO LETTER DENOTES NEW, *R' DENOTES RELOCATED EXISTING.</p> <p>▭ EXISTING SUPPLY AIR SLOT, NO LETTER DENOTES TO REMAIN, *R' DENOTES TO BE REMOVED AND REUSED AS APPLICABLE.</p> <p>▭ RETURN AIR SLOT, NO LETTER DENOTES NEW, *R' DENOTES RELOCATED EXISTING.</p> <p>▭ EXISTING RETURN AIR SLOT, NO LETTER DENOTES TO REMAIN, *R' DENOTES TO BE REMOVED AND RELOCATED AS APPLICABLE.</p> <p>▭ NEW RECTANGULAR OR ROUND DUCTWORK</p> <p>▭ EXISTING DUCTWORK</p> <p>▭ EXISTING RECTANGULAR OR ROUND DUCTWORK TO BE REMOVED AND RELOCATED AS APPLICABLE</p> <p>▭ NEW FLEXIBLE DUCT</p> <p>▭ EXISTING FLEXIBLE DUCT</p> <p>▭ EXISTING FLEXIBLE DUCT TO BE REMOVED</p> <p>☒ SUPPLY OR OUTSIDE AIR DUCT</p> <p>☒ RETURN, RELIEF, OR EXHAUST AIR DUCT</p> <p>▭ INCLINED RISE IN DUCT</p> <p>▭ INCLINED DROP IN DUCT</p> <p>▭ TURNING VANES</p> <p>▭ DUCT MOUNTED HUMIDIFIER</p> <p>▭ DOUBLE DUCT HVAC TERMINAL UNIT</p> <p>▭ FIRE DAMPER</p> <p>▭ SMOKE DAMPER</p> <p>▭ FIRE/SMOKE DAMPER</p> <p>▭ MANUAL BALANCING DAMPER</p> <p>▭ GRAVITY BACKDRAFT DAMPER</p> <p>▭ MOTORIZED DAMPER</p> <p>MISCELLANEOUS</p> <p>① DRAWING NOTE REFERENCE</p> <p>Ⓢ DISTRIBUTION DEVICE REFERENCE.</p> <p>Ⓢ bbb TYPE, *bbb' DENOTES CFM, *cc/dd' DENOTES NECK SIZE</p> <p>Ⓢ cc/dd</p> <p>Ⓢ bbb ccc KW HVAC TERMINAL UNIT REFERENCE. *aaa' DENOTES TYPE, *bbb' DENOTES CFM, *ccc KW' DENOTES HEATING KW WHERE APPLICABLE</p> <p>Ⓢ THERMOSTAT</p> <p>Ⓢ HUMIDISTAT</p> <p>Ⓢ FIRESTAT</p> <p>Ⓢ DUCT SMOKE DETECTOR, *RA' DENOTES RETURN AIR</p> <p>▭ EXISTING LIGHT FIXTURE NIC OR TO REMAIN</p> <p>▭ EXISTING LIGHT FIXTURE TO BE REMOVED</p> <p>▭ NEW LIGHT FIXTURE</p>	<p>MECHANICAL NOTES</p> <p>A. REFER TO SPECIFICATIONS FOR MATERIALS AND METHODS FOR MECHANICAL CONSTRUCTION.</p> <p>B. ALL DUCTWORK SIZES SHOWN ARE FREE AIR STREAM DIMENSIONS.</p> <p>C. FURNISH ACCESS DOORS FOR INSTALLATION BY THE GENERAL CONTRACTOR IN WALLS AND CEILINGS WHERE ACCESS IS REQUIRED TO CONCEALED MECHANICAL EQUIPMENT, VALVES, CONTROLS AND OTHER DEVICES.</p> <p>D. ALL DUCTWORK SHALL BE INSTALLED A MINIMUM OF 8 INCHES ABOVE THE FINISHED CEILING TO PROVIDE CLEARANCE FOR PIPING, ELECTRICAL CONDUIT AND LIGHTING FIXTURES.</p> <p>E. ALL SUPPLY AIR DUFFUSERS ARE 4-WAY THROW, UNLESS OTHERWISE NOTED ON THE DRAWINGS WITH FLOW ARROWS.</p> <p>F. COORDINATE THE EXACT LOCATIONS OF HVAC TERMINAL UNITS WITH LOCATIONS OF LIGHTING FIXTURES, PIPING AND OTHER CONSTRUCTION, TO ALLOW FOR PROPER ACCESS TO SERVICE TERMINAL UNITS.</p> <p>G. THE MECHANICAL CONTRACTOR SHALL BE RESPONSIBLE FOR COORDINATING THE LOCATION OF DUCTWORK AND PIPING WITH OTHER TRADES AND PROVIDING OFFSETS IN DUCTWORK AND PIPING AS REQUIRED.</p> <p>SHEET LIST</p> <table border="1"> <thead> <tr> <th>ME 000</th> <th>MECHANICAL & ELECTRICAL SYMBOLS & ABBREVIATIONS</th> </tr> </thead> <tbody> <tr> <td>AE 1.61</td> <td>ARCHITECTURAL/LIGHTING DEMO RCP AREA A</td> </tr> <tr> <td>AE 1.62</td> <td>ARCHITECTURAL/LIGHTING DEMO RCP AREA B</td> </tr> <tr> <td>AE 1.63</td> <td>ARCHITECTURAL/LIGHTING DEMO RCP AREA C</td> </tr> <tr> <td>AE 1.64</td> <td>ARCHITECTURAL/LIGHTING DEMO RCP AREA D</td> </tr> <tr> <td>AE 1.65</td> <td>ARCHITECTURAL/LIGHTING DEMO RCP AREA E</td> </tr> <tr> <td>AE 1.66</td> <td>ARCHITECTURAL/LIGHTING DEMO RCP AREA F</td> </tr> <tr> <td>AE 2.61</td> <td>ARCHITECTURAL/LIGHTING RENO RCP AREA A</td> </tr> <tr> <td>AE 2.62</td> <td>ARCHITECTURAL/LIGHTING RENO RCP AREA B</td> </tr> <tr> <td>AE 2.63</td> <td>ARCHITECTURAL/LIGHTING RENO RCP AREA C</td> </tr> <tr> <td>AE 2.64</td> <td>ARCHITECTURAL/LIGHTING RENO RCP AREA D</td> </tr> <tr> <td>AE 2.65</td> <td>ARCHITECTURAL/LIGHTING RENO RCP AREA E</td> </tr> <tr> <td>AE 2.66</td> <td>ARCHITECTURAL/LIGHTING RENO RCP AREA F</td> </tr> <tr> <td>M 1.61</td> <td>MECHANICAL DEMO AREA A</td> </tr> <tr> <td>M 1.62</td> <td>MECHANICAL DEMO AREA B</td> </tr> <tr> <td>M 1.63</td> <td>MECHANICAL DEMO AREA C</td> </tr> <tr> <td>M 1.64</td> <td>MECHANICAL DEMO AREA D</td> </tr> <tr> <td>M 1.65</td> <td>MECHANICAL DEMO AREA E</td> </tr> <tr> <td>M 1.66</td> <td>MECHANICAL DEMO AREA F</td> </tr> <tr> <td>M 2.61</td> <td>MECHANICAL RENO AREA A</td> </tr> <tr> <td>M 2.62</td> <td>MECHANICAL RENO AREA B</td> </tr> <tr> <td>M 2.63</td> <td>MECHANICAL RENO AREA C</td> </tr> <tr> <td>M 2.64</td> <td>MECHANICAL RENO AREA D</td> </tr> <tr> <td>M 2.65</td> <td>MECHANICAL RENO AREA E</td> </tr> <tr> <td>M 2.66</td> <td>MECHANICAL RENO AREA F</td> </tr> <tr> <td>M 4.01</td> <td>MECHANICAL SCHEDULES</td> </tr> <tr> <td>M 5.01</td> <td>MECHANICAL DETAILS</td> </tr> <tr> <td>M 6.01</td> <td>CONTROL DIAGRAM</td> </tr> </tbody> </table> <p>KEY MAP AREAS</p>  <p>HEATHER CAMDEN PROFESSIONAL ENGINEER LICENSED 66863</p> <p>THE SEAL APPEARING ON THIS DRAWING WAS AUTHORIZED BY: Digitally signed by Heather Camden Camden Date: 2017.03.03 11:00:55-0600' E&C Engineers & Consultants Inc. Texas Firm Registration No: F-003068</p>	ME 000	MECHANICAL & ELECTRICAL SYMBOLS & ABBREVIATIONS	AE 1.61	ARCHITECTURAL/LIGHTING DEMO RCP AREA A	AE 1.62	ARCHITECTURAL/LIGHTING DEMO RCP AREA B	AE 1.63	ARCHITECTURAL/LIGHTING DEMO RCP AREA C	AE 1.64	ARCHITECTURAL/LIGHTING DEMO RCP AREA D	AE 1.65	ARCHITECTURAL/LIGHTING DEMO RCP AREA E	AE 1.66	ARCHITECTURAL/LIGHTING DEMO RCP AREA F	AE 2.61	ARCHITECTURAL/LIGHTING RENO RCP AREA A	AE 2.62	ARCHITECTURAL/LIGHTING RENO RCP AREA B	AE 2.63	ARCHITECTURAL/LIGHTING RENO RCP AREA C	AE 2.64	ARCHITECTURAL/LIGHTING RENO RCP AREA D	AE 2.65	ARCHITECTURAL/LIGHTING RENO RCP AREA E	AE 2.66	ARCHITECTURAL/LIGHTING RENO RCP AREA F	M 1.61	MECHANICAL DEMO AREA A	M 1.62	MECHANICAL DEMO AREA B	M 1.63	MECHANICAL DEMO AREA C	M 1.64	MECHANICAL DEMO AREA D	M 1.65	MECHANICAL DEMO AREA E	M 1.66	MECHANICAL DEMO AREA F	M 2.61	MECHANICAL RENO AREA A	M 2.62	MECHANICAL RENO AREA B	M 2.63	MECHANICAL RENO AREA C	M 2.64	MECHANICAL RENO AREA D	M 2.65	MECHANICAL RENO AREA E	M 2.66	MECHANICAL RENO AREA F	M 4.01	MECHANICAL SCHEDULES	M 5.01	MECHANICAL DETAILS	M 6.01	CONTROL DIAGRAM
ME 000	MECHANICAL & ELECTRICAL SYMBOLS & ABBREVIATIONS																																																											
AE 1.61	ARCHITECTURAL/LIGHTING DEMO RCP AREA A																																																											
AE 1.62	ARCHITECTURAL/LIGHTING DEMO RCP AREA B																																																											
AE 1.63	ARCHITECTURAL/LIGHTING DEMO RCP AREA C																																																											
AE 1.64	ARCHITECTURAL/LIGHTING DEMO RCP AREA D																																																											
AE 1.65	ARCHITECTURAL/LIGHTING DEMO RCP AREA E																																																											
AE 1.66	ARCHITECTURAL/LIGHTING DEMO RCP AREA F																																																											
AE 2.61	ARCHITECTURAL/LIGHTING RENO RCP AREA A																																																											
AE 2.62	ARCHITECTURAL/LIGHTING RENO RCP AREA B																																																											
AE 2.63	ARCHITECTURAL/LIGHTING RENO RCP AREA C																																																											
AE 2.64	ARCHITECTURAL/LIGHTING RENO RCP AREA D																																																											
AE 2.65	ARCHITECTURAL/LIGHTING RENO RCP AREA E																																																											
AE 2.66	ARCHITECTURAL/LIGHTING RENO RCP AREA F																																																											
M 1.61	MECHANICAL DEMO AREA A																																																											
M 1.62	MECHANICAL DEMO AREA B																																																											
M 1.63	MECHANICAL DEMO AREA C																																																											
M 1.64	MECHANICAL DEMO AREA D																																																											
M 1.65	MECHANICAL DEMO AREA E																																																											
M 1.66	MECHANICAL DEMO AREA F																																																											
M 2.61	MECHANICAL RENO AREA A																																																											
M 2.62	MECHANICAL RENO AREA B																																																											
M 2.63	MECHANICAL RENO AREA C																																																											
M 2.64	MECHANICAL RENO AREA D																																																											
M 2.65	MECHANICAL RENO AREA E																																																											
M 2.66	MECHANICAL RENO AREA F																																																											
M 4.01	MECHANICAL SCHEDULES																																																											
M 5.01	MECHANICAL DETAILS																																																											
M 6.01	CONTROL DIAGRAM																																																											

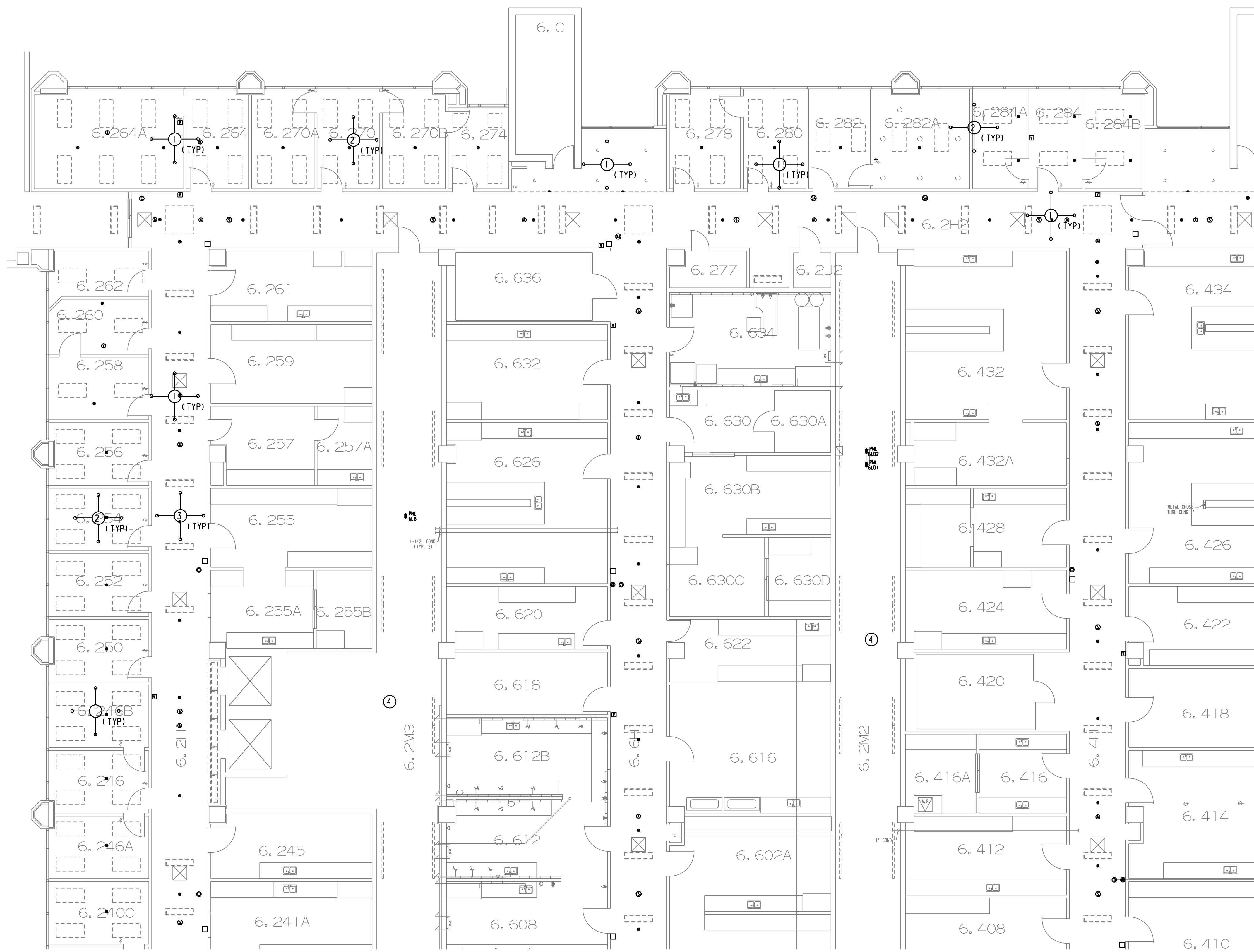

GENERAL NOTES:

A. THE INTENT OF THE DRAWINGS IS NOT TO RELOCATE SPRINKLER HEADS OR FA DEVICES. IF NEW LIGHT OR DIFFUSER LOCATION DOES NOT WORK WITH EXISTING SPRINKLER/FA DEVICE, PLEASE CONTACT ENGINEER OF RECORD FOR FURTHER DIRECTION. APPROXIMATE LOCATIONS OF DEVICES ARE SHOWN.

DRAWINGS NOTES:

- ① DEMOLISH THE GRID.
- ② DEMOLISH THE LIGHT FIXTURES. CIRCUITING TO BE REUSED. REMOVE SWITCH FOR REPLACEMENT.
- ③ DEMOLISH THE LIGHT FIXTURES IN THE HALLWAY. CIRCUITING TO BE REUSED.
- ④ DEMOLISH THE LIGHT FIXTURES IN THE CHASES. CIRCUITING TO BE REUSED. REMOVE 3-WAY TIMER SWITCHES.

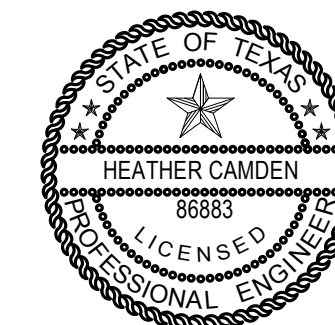
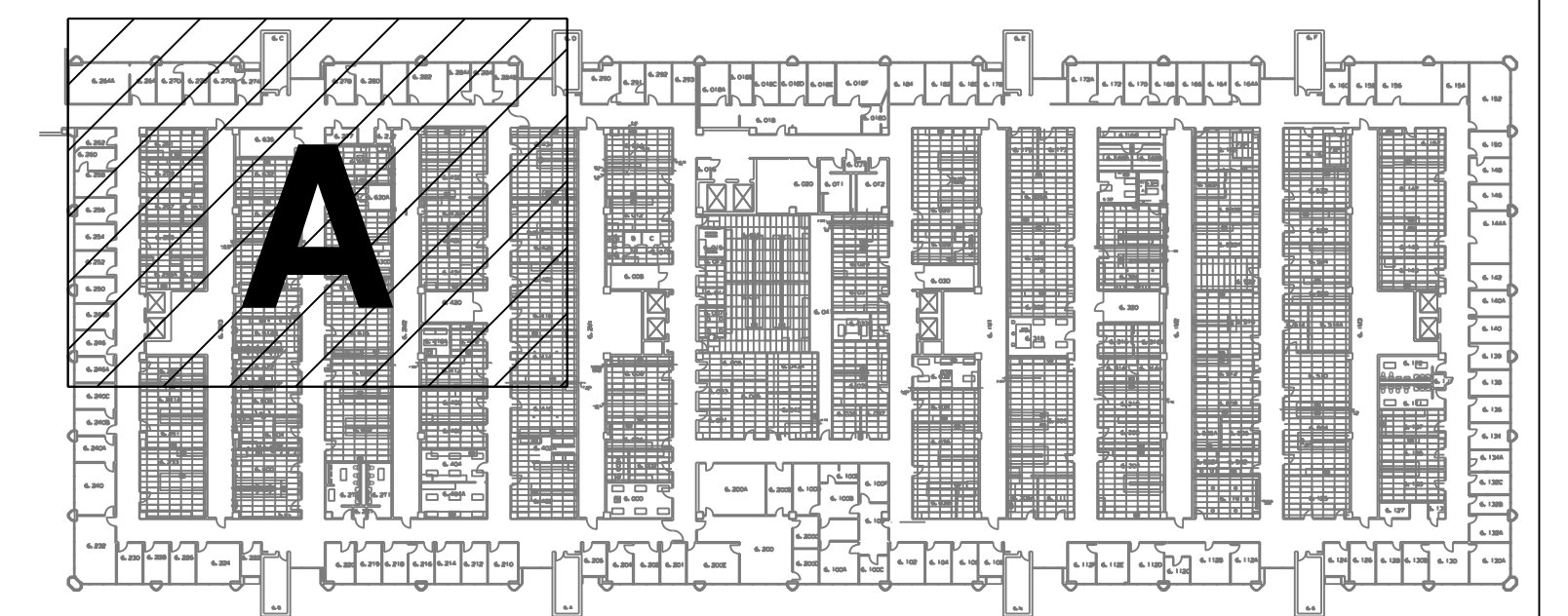

THE SEAL APPEARING ON THIS DRAWING WAS AUTHORIZED BY:
 Digitally signed by Heather Camden
 Date: 2017.03.03 11:00:55-06'00'
 E&C Engineers & Consultants Inc.
 Texas Firm Registration No: F-003068

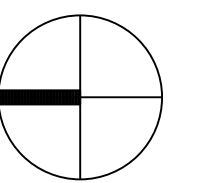

1 ELECTRICAL/CEILING DEMO AREA A PLAN
 SCALE: 1/8" = 1'-0"

**UTHSC
 MSB OFFICE AIR DISTRIBUTION-6TH FLOOR**

E&C PROJECT # 3300

E&C
 Engineers & Consultants Inc.
 TX Firm Registration No: F-003068
 1010 Lamar, Suite 650
 Houston, Texas 77002
 Tel 713/580-8800
 Fax 713/580-8888
 www.eceng.com

SKETCH: DEMO AREA A
DRAWING: AE 1.61
REVISION: CONSTRUCTION
SCALE: 1/8"=1'-0"
DATE: 03-03-2017

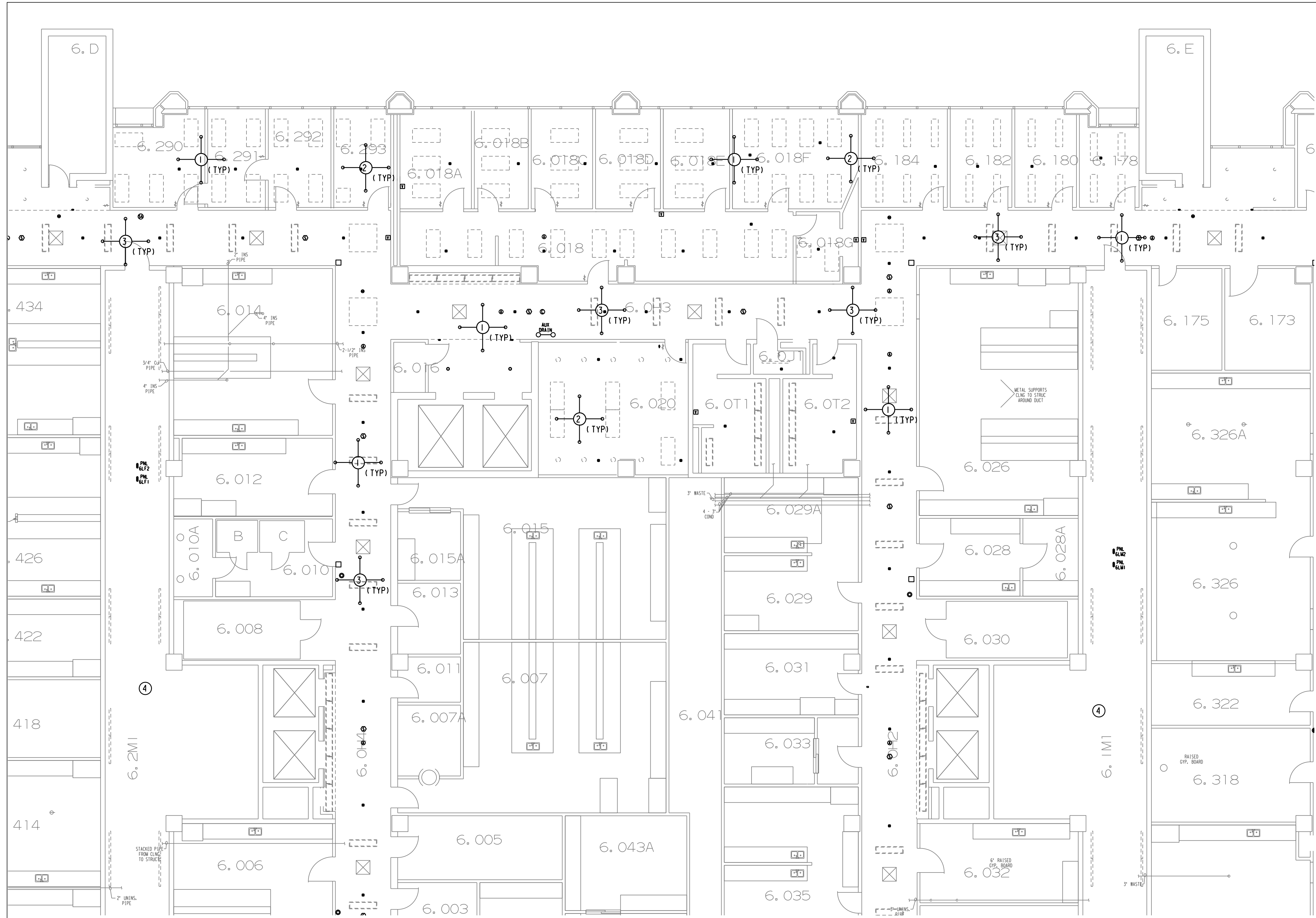

GENERAL NOTES:

A. THE INTENT OF THE DRAWINGS IS NOT TO RELOCATE SPRINKLER HEADS OR FA DEVICES. IF NEW LIGHT OR DIFFUSER LOCATION DOES NOT WORK WITH EXISTING SPRINKLER/FA DEVICE, PLEASE CONTACT ENGINEER OF RECORD FOR FURTHER DIRECTION. APPROXIMATE LOCATIONS OF DEVICES ARE SHOWN.

- DRAWINGS NOTES:**
- ① DEMOLISH THE GRID.
 - ② DEMOLISH THE LIGHT FIXTURES. CIRCUITING TO BE REUSED. REMOVE SWITCH FOR REPLACEMENT.
 - ③ DEMOLISH THE LIGHT FIXTURES IN THE HALLWAY. CIRCUITING TO BE REUSED.
 - ④ DEMOLISH THE LIGHT FIXTURES IN THE CHASES. CIRCUITING TO BE REUSED. REMOVE 3-WAY TIMER SWITCHES.

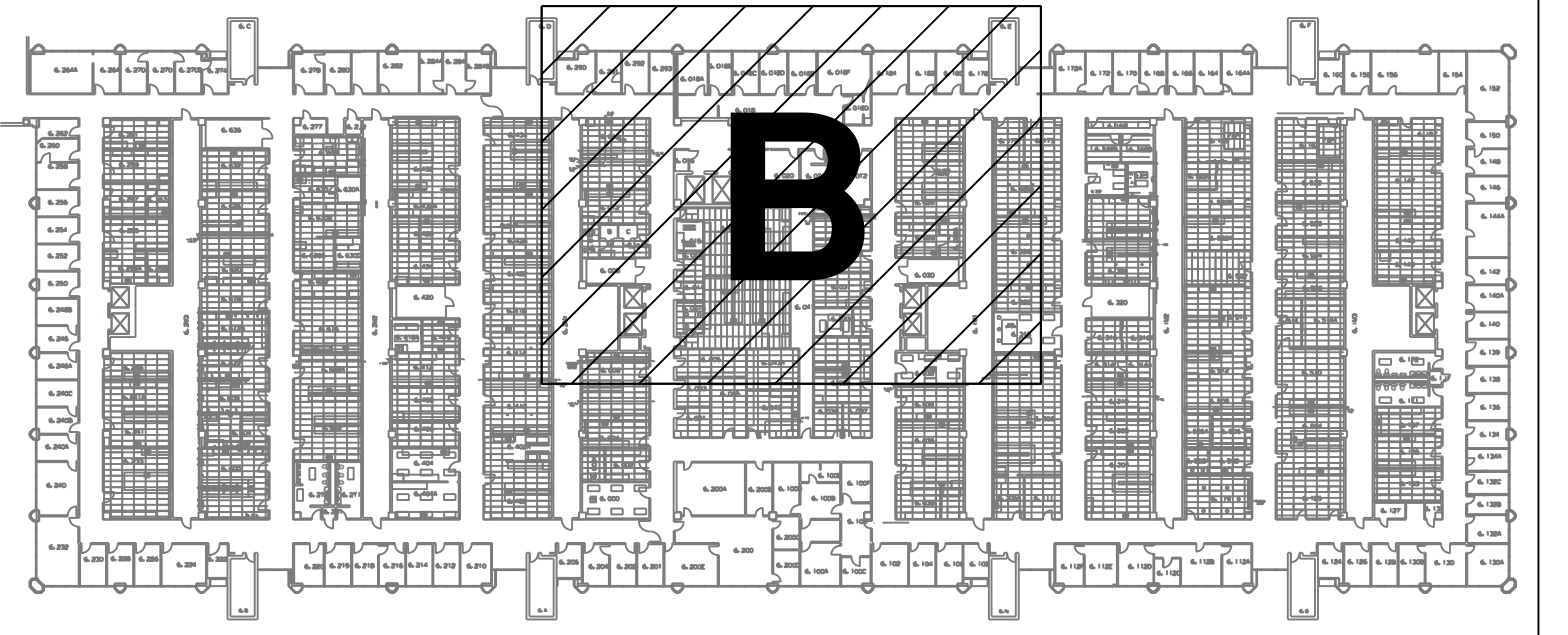

1 ARCH/LIGHTING DEMO AREA B PLAN
SCALE: 1/8" = 1'-0"

THE SEAL APPEARING ON THIS DRAWING WAS AUTHORIZED BY:
Digitally signed by Heather Camden
Date: 2017.03.03 11:00:55-06'00'
E&C Engineers & Consultants Inc.
Texas Firm Registration No: F-003068

**UTHSC
MSB OFFICE AIR DISTRIBUTION-6TH FLOOR**

E&C
Engineers & Consultants Inc.
TX Firm Registration No: F-003068
1010 Lamar, Suite 650
Houston, Texas 77002
Tel 713/580-8800
Fax 713/580-8888
www.eceng.com

E&C PROJECT # 3300

SKETCH: DEMO AREA B
DRAWING: AE 1.62
REVISION: CONSTRUCTION
SCALE: 1/8"=1'-0"
DATE: 03-03-2017

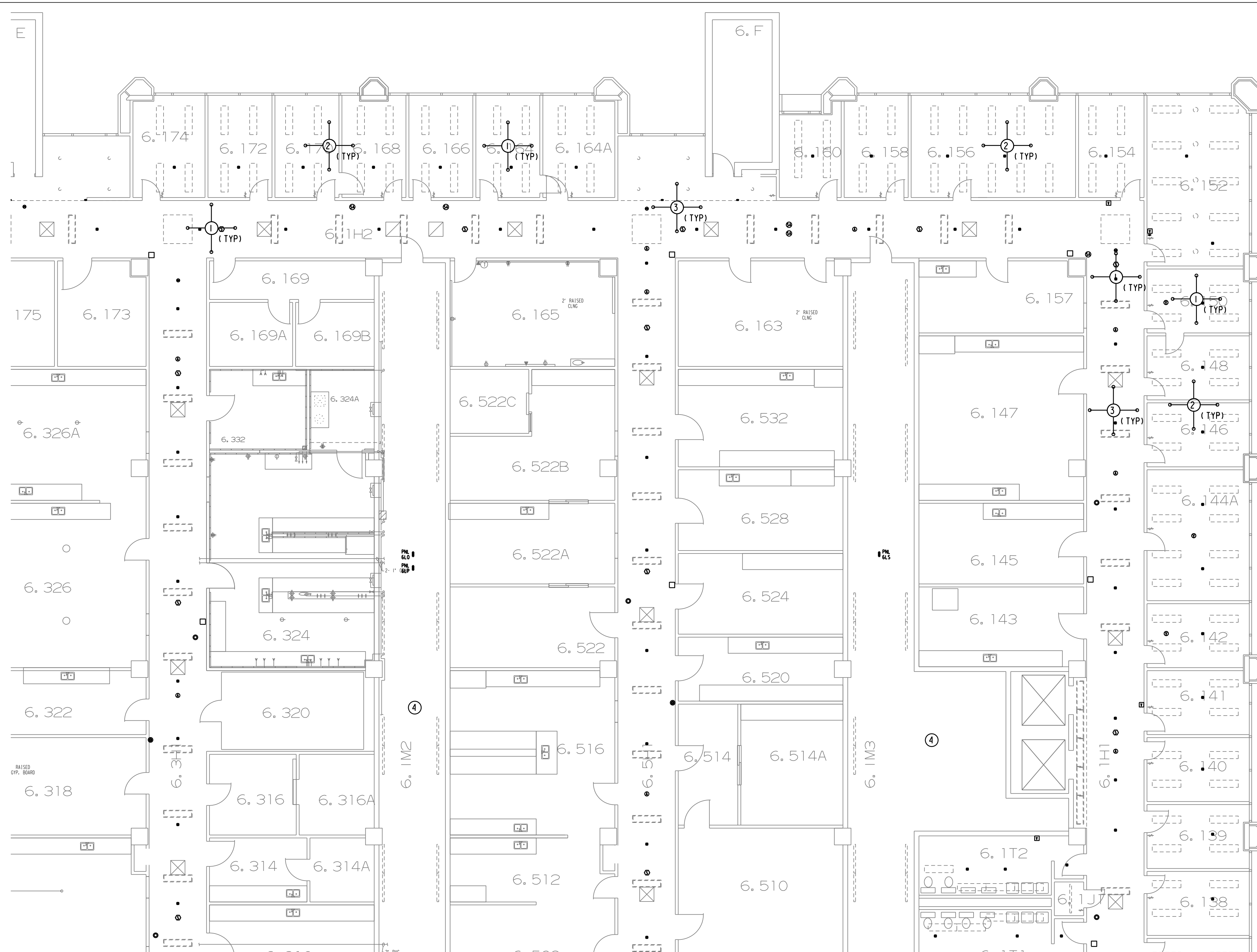

GENERAL NOTES:

A. THE INTENT OF THE DRAWINGS IS NOT TO RELOCATE SPRINKLER HEADS OR FA DEVICES. IF NEW LIGHT OR DIFFUSER LOCATION DOES NOT WORK WITH EXISTING SPRINKLER/FA DEVICE, PLEASE CONTACT ENGINEER OF RECORD FOR FURTHER DIRECTION. APPROXIMATE LOCATIONS OF DEVICES ARE SHOWN.

DRAWINGS NOTES:

- ① DEMOLISH THE GRID.
- ② DEMOLISH THE LIGHT FIXTURES. CIRCUITING TO BE REUSED. REMOVE SWITCH FOR REPLACEMENT.
- ③ DEMOLISH THE LIGHT FIXTURES IN THE HALLWAY. CIRCUITING TO BE REUSED.
- ④ DEMOLISH THE LIGHT FIXTURES IN THE CHASES. CIRCUITING TO BE REUSED. REMOVE 3-WAY TIMER SWITCHES.

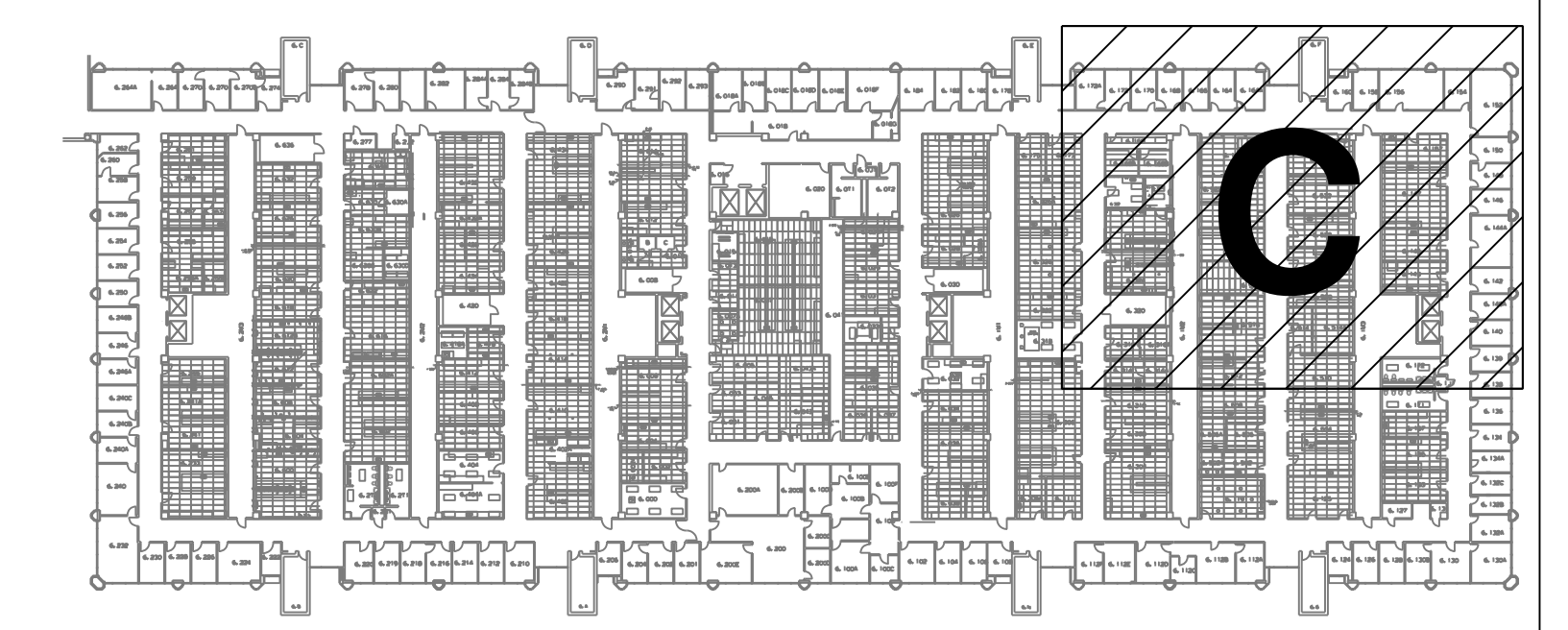

1 ARCH/LIGHTING DEMO AREA C PLAN
SCALE: 1/8" = 1'-0"

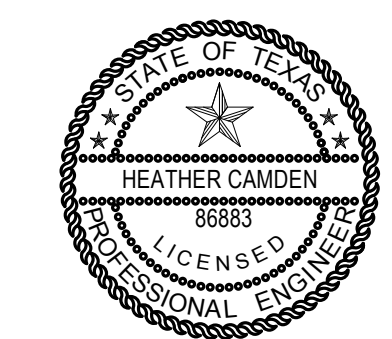

THE SEAL APPEARING ON THIS DRAWING WAS AUTHORIZED BY:
Digitally signed by Heather Camden
Date: 2017.03.03 11:00:55-06'00'
E&C Engineers & Consultants Inc.
Texas Firm Registration No: F-003068

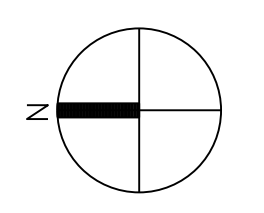

E&C
Engineers & Consultants Inc.
TX Firm Registration No: F-003068
1010 Lamar, Suite 650
Houston, Texas 77002
Tel 713/580-8800
Fax 713/580-8888
www.eceng.com

**UTHSC
MSB OFFICE AIR DISTRIBUTION-6TH FLOOR**

E&C PROJECT # 3300

SKETCH: DEMO AREA C
DRAWING: AE 1.63
REVISION: CONSTRUCTION
SCALE: 1/8"=1'-0"
DATE: 03-03-2017

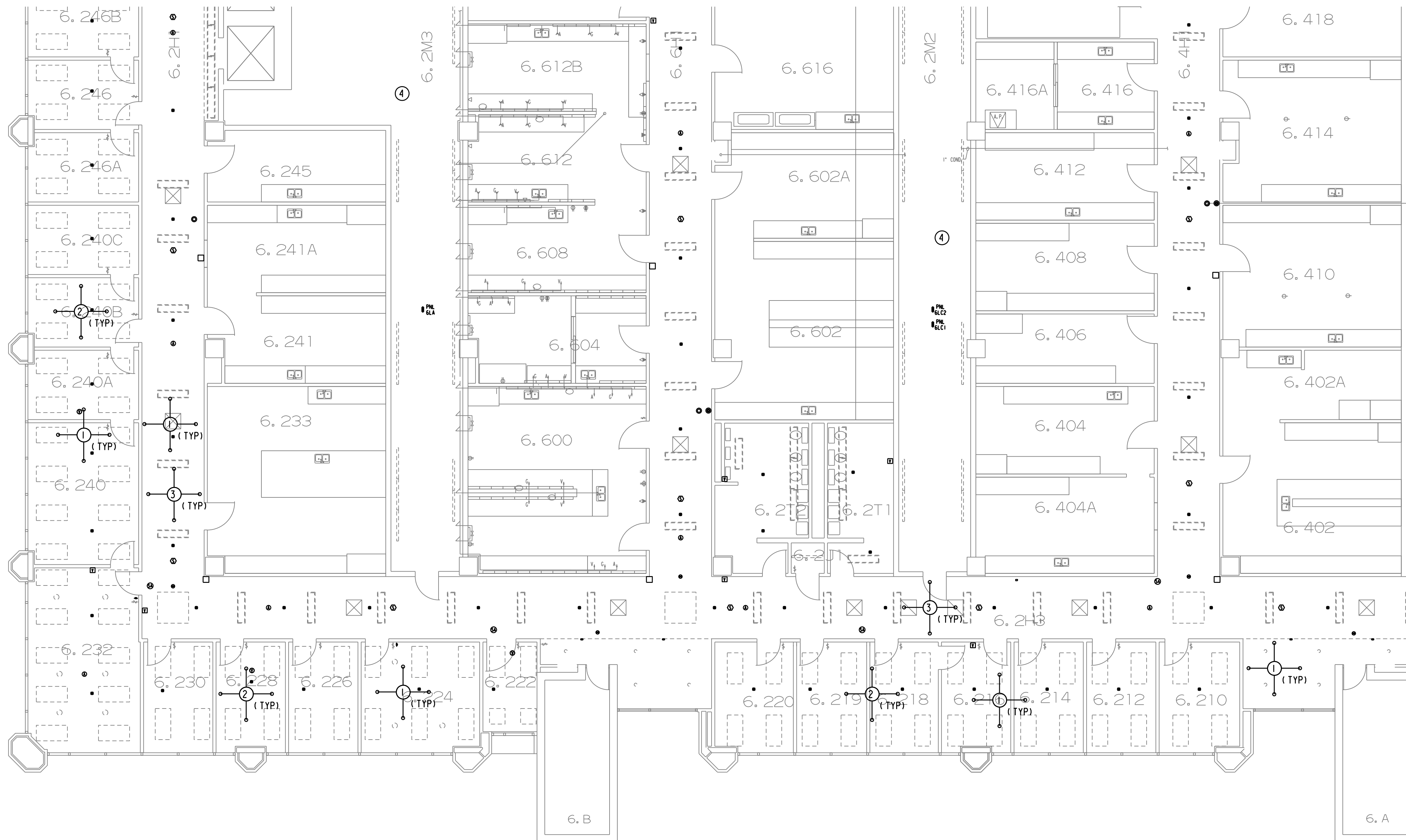

GENERAL NOTES:

A. THE INTENT OF THE DRAWINGS IS NOT TO RELOCATE SPRINKLER HEADS OR FA DEVICES. IF NEW LIGHT OR DIFFUSER LOCATION DOES NOT WORK WITH EXISTING SPRINKLER/FA DEVICE, PLEASE CONTACT ENGINEER OF RECORD FOR FURTHER DIRECTION. APPROXIMATE LOCATIONS OF DEVICES ARE SHOWN.

DRAWINGS NOTES:

- ① DEMOLISH THE GRID.
- ② DEMOLISH THE LIGHT FIXTURES. CIRCUITING TO BE REUSED. REMOVE SWITCH FOR REPLACEMENT.
- ③ DEMOLISH THE LIGHT FIXTURES IN THE HALLWAY. CIRCUITING TO BE REUSED.
- ④ DEMOLISH THE LIGHT FIXTURES IN THE CHASES. CIRCUITING TO BE REUSED. REMOVE 3-WAY TIMER SWITCHES.

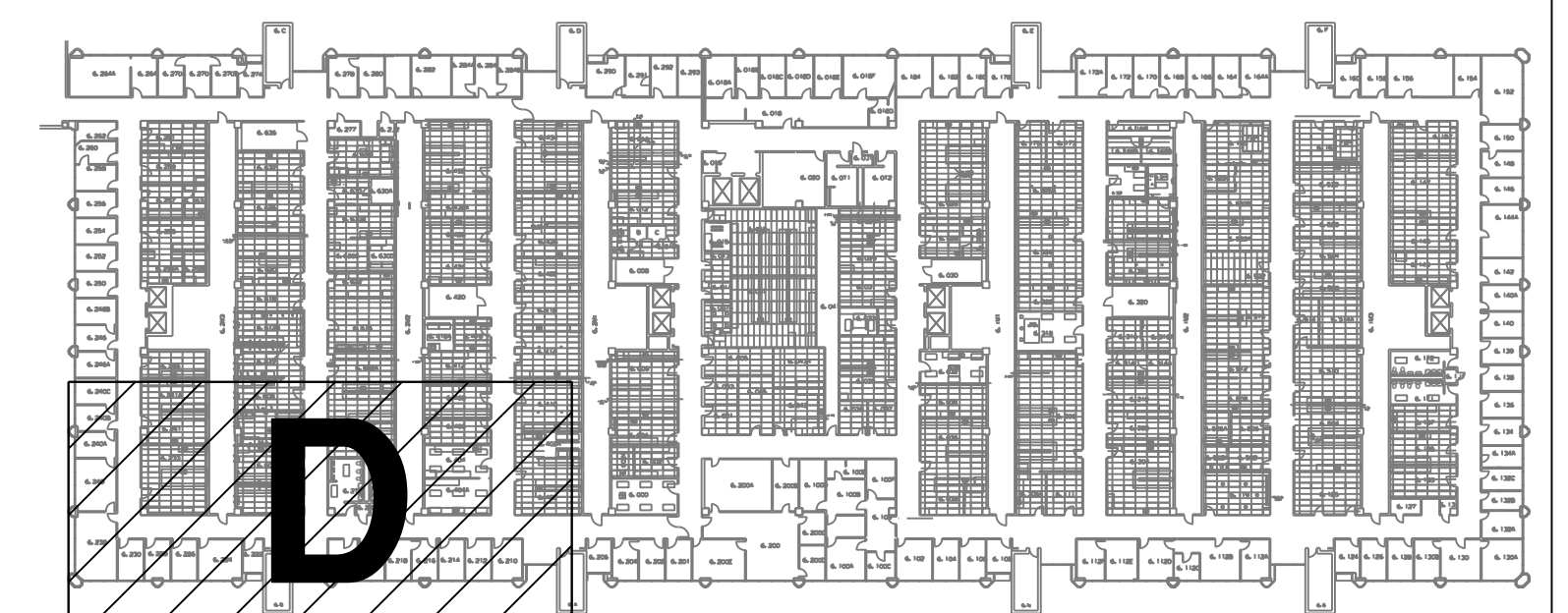

1 ARCH/LIGHTING DEMO AREA D PLAN
SCALE: 1/8" = 1' - 0"

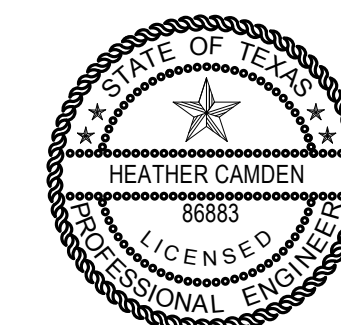

THE SEAL APPEARING ON THIS DRAWING WAS AUTHORIZED BY:
Digitally signed by Heather Camden
Date: 2017.03.03 11:00:55-06'00'
E&C Engineers & Consultants Inc.
Texas Firm Registration No: F-003068

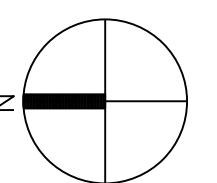

E&C
Engineers & Consultants Inc.
TX Firm Registration No: F-003068
1010 Lamar, Suite 650
Houston, Texas 77002
Tel 713/580-8800
Fax 713/580-8888
www.eceng.com

**UTHSC
MSB OFFICE AIR DISTRIBUTION-6TH FLOOR**

E&C PROJECT # 3300

SKETCH: DEMO AREA D
DRAWING: AE 1.64
REVISION: CONSTRUCTION
SCALE: 1/8"=1'-0"
DATE: 03-03-2017

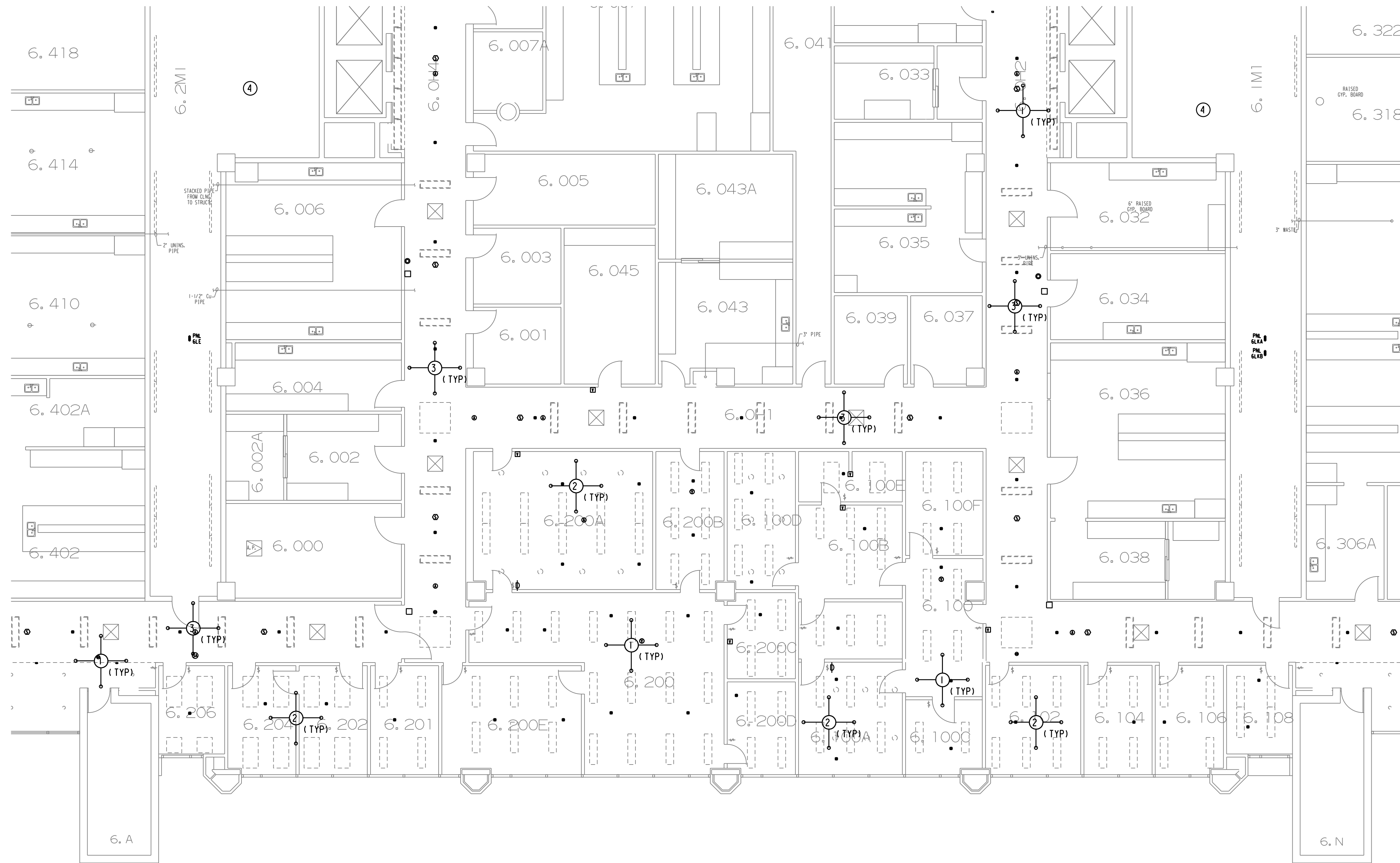

GENERAL NOTES:

A. THE INTENT OF THE DRAWINGS IS NOT TO RELOCATE SPRINKLER HEADS OR FA DEVICES. IF NEW LIGHT OR DIFFUSER LOCATION DOES NOT WORK WITH EXISTING SPRINKLER/FA DEVICE, PLEASE CONTACT ENGINEER OF RECORD FOR FURTHER DIRECTION. APPROXIMATE LOCATIONS OF DEVICES ARE SHOWN.

DRAWINGS NOTES:

- ① DEMOLISH THE GRID.
- ② DEMOLISH THE LIGHT FIXTURES. CIRCUITING TO BE REUSED. REMOVE SWITCH FOR REPLACEMENT.
- ③ DEMOLISH THE LIGHT FIXTURES IN THE HALLWAY. CIRCUITING TO BE REUSED.
- ④ DEMOLISH THE LIGHT FIXTURES IN THE CHASES. CIRCUITING TO BE REUSED. REMOVE 3-WAY TIMER SWITCHES.

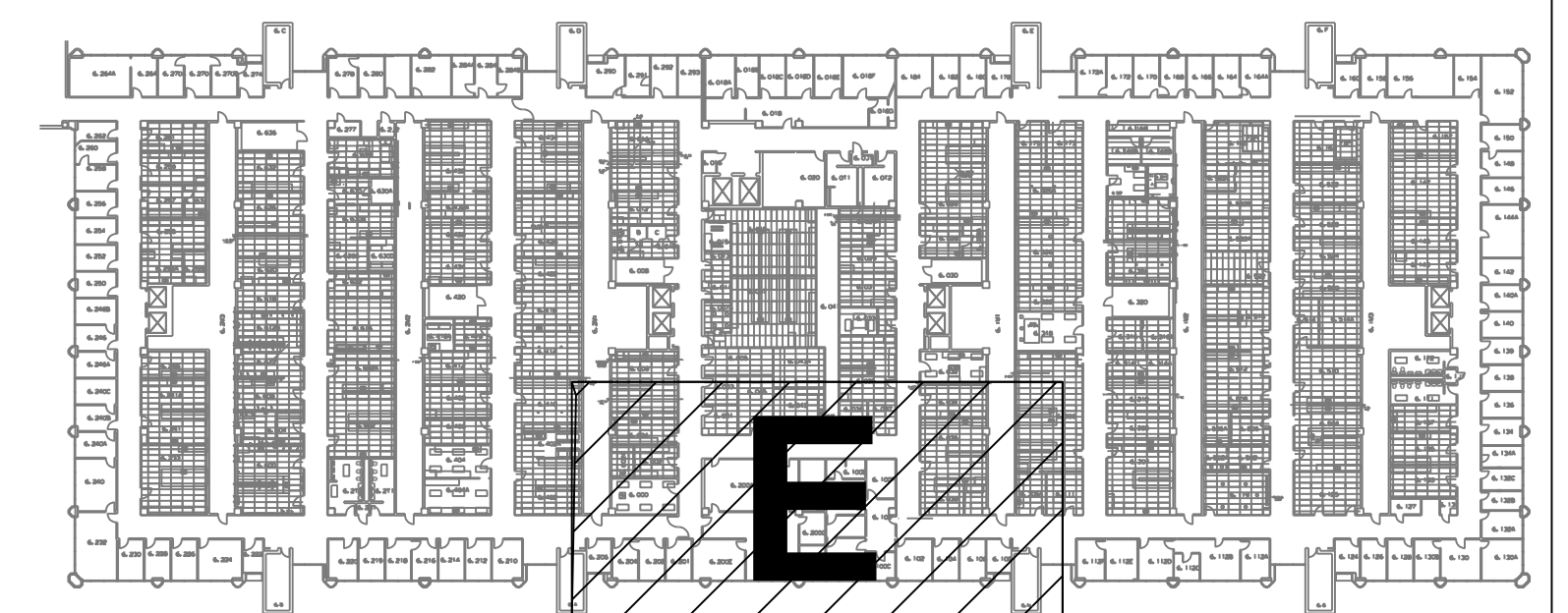

These documents are for review only

1 ARCH/LIGHTING DEMO AREA E PLAN
SCALE: 1/8" = 1'-0"

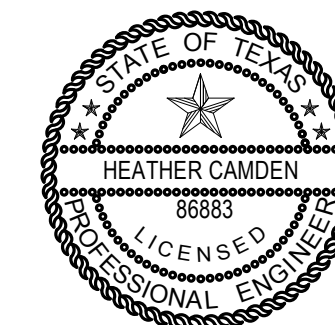

THE SEAL APPEARING ON THIS DRAWING WAS AUTHORIZED BY:
Digitally signed by Heather Camden
Date: 2017.03.03 11:00:55-06'00'
E&C Engineers & Consultants Inc.
Texas Firm Registration No: F-003068

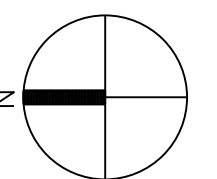

E&C
Engineers & Consultants Inc.
TX Firm Registration No: F-003068
1010 Lamar, Suite 650
Houston, Texas 77002
Tel 713/580-8800
Fax 713/580-8888
www.eceng.com

**UTHSC
MSB OFFICE AIR DISTRIBUTION-6TH FLOOR**

E&C PROJECT # 3300

SKETCH: DEMO AREA E
DRAWING: AE 1.65
REVISION: CONSTRUCTION
SCALE: 1/8"=1'-0"
DATE: 03-03-2017

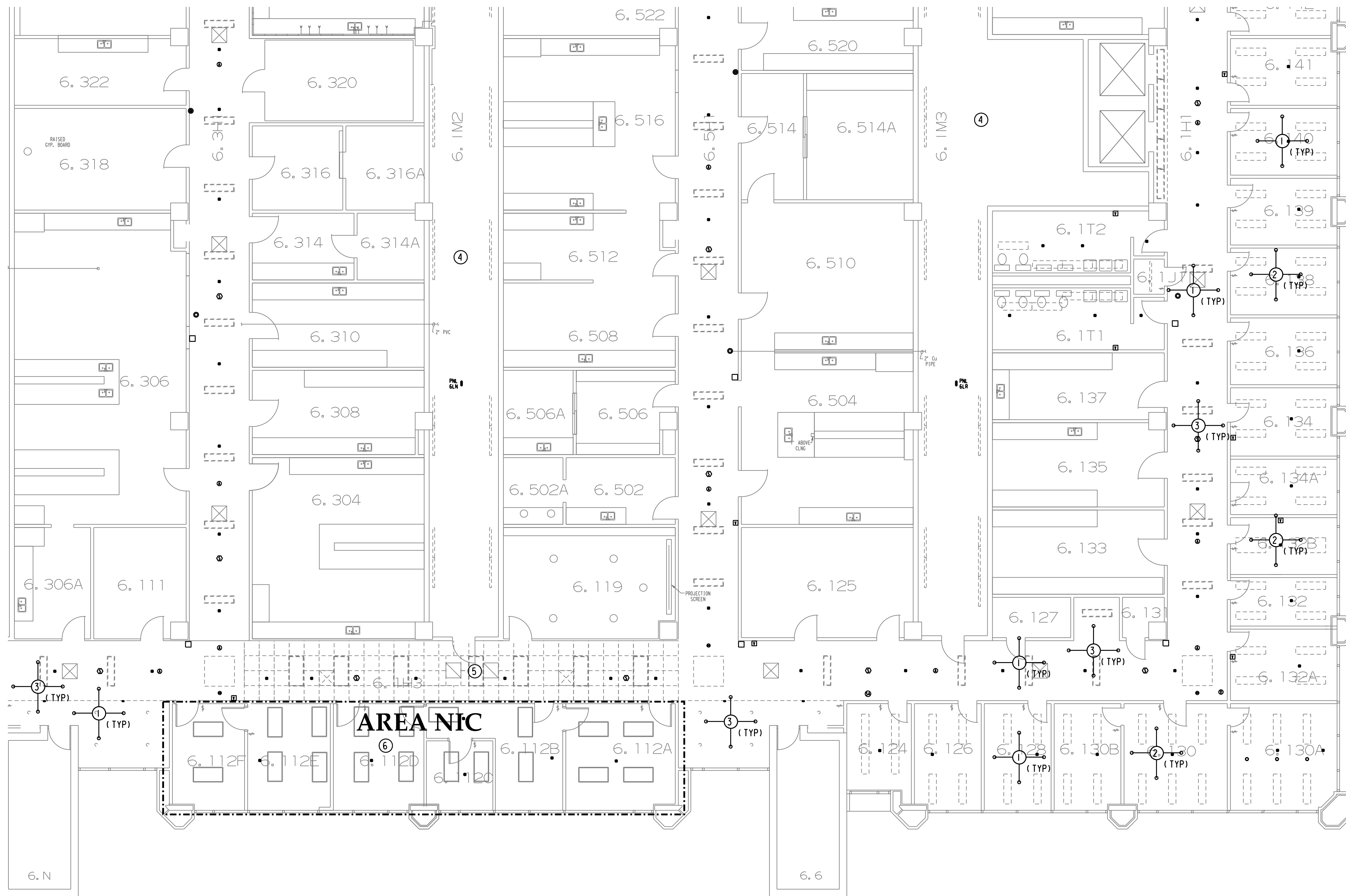

GENERAL NOTES:
 A. THE INTENT OF THE DRAWINGS IS NOT TO RELOCATE SPRINKLER HEADS OR FA DEVICES. IF NEW LIGHT OR DIFFUSER LOCATION DOES NOT WORK WITH EXISTING SPRINKLER/FA DEVICE, PLEASE CONTACT ENGINEER OF RECORD FOR FURTHER DIRECTION. APPROXIMATE LOCATIONS OF DEVICES ARE SHOWN.

- DRAWINGS NOTES:**
- ① DEMOLISH THE GRID.
 - ② DEMOLISH THE LIGHT FIXTURES. CIRCUITING TO BE REUSED. REMOVE SWITCH FOR REPLACEMENT.
 - ③ DEMOLISH THE LIGHT FIXTURES IN THE HALLWAY. CIRCUITING TO BE REUSED.
 - ④ DEMOLISH THE LIGHT FIXTURES IN THE CHASES. CIRCUITING TO BE REUSED. REMOVE 3-WAY TIMER SWITCHES.
 - ⑤ THIS AREA IS NEWER CEILING. TILES MAY BE SALVAGED FOR REUSE. LIGHT FIXTURES AND DIFFUSERS SHALL BE SALVAGED FOR RELOCATION. SMOKE ALARM, SPRINKLERS, AND OTHER CEILING MOUNTED DEVICES SHOWN WILL NEED TO BE RELOCATED TO LAY OUT WITH THE NEW CEILING PATTERN.
 - ⑥ AREAS NOTED NIC ARE NEWLY REMODELED AND WILL NOT BE INCLUDED.

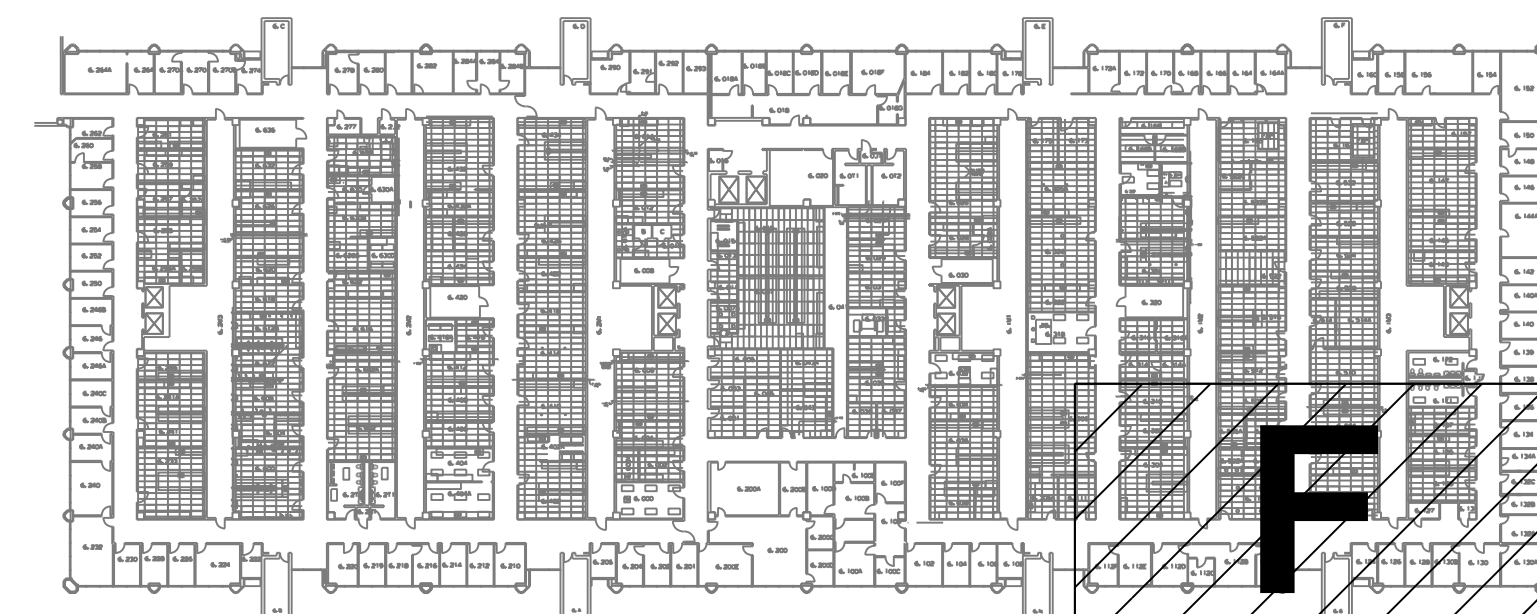

1 ARCH/LIGHTING DEMO AREA F PLAN
 SCALE: 1/8" = 1'-0"

THE SEAL APPEARING ON THIS DRAWING WAS AUTHORIZED BY:
 Digitally signed by Heather Camden
 Date: 2017.03.03 11:00:55-06'00'
 E&C Engineers & Consultants Inc.
 Texas Firm Registration No: F-003068

E&C
 Engineers & Consultants Inc.
 TX Firm Registration No: F-003068
 1010 Lamar, Suite 650
 Houston, Texas 77002
 Tel 713/580-8800
 Fax 713/580-8888
 www.eceng.com

**UTHSC
 MSB OFFICE AIR DISTRIBUTION-6TH FLOOR**

E&C PROJECT # 3300

SKETCH: DEMO AREA F
DRAWING: AE 1.66
REVISION: CONSTRUCTION
SCALE: 1/8"=1'-0"
DATE: 03-03-2017

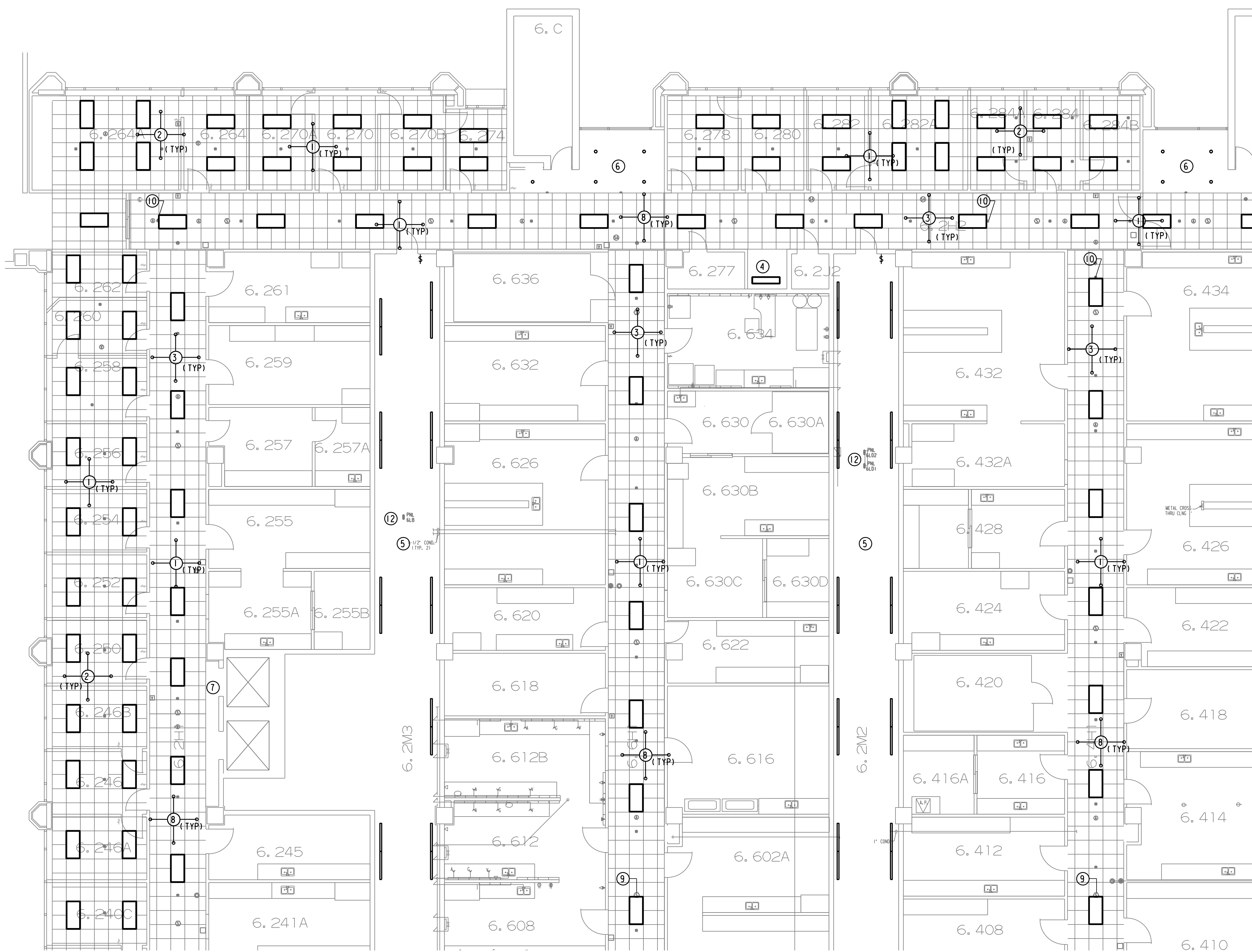

GENERAL NOTES:

A. THE INTENT OF THE DRAWINGS IS NOT TO RELOCATE SPRINKLER HEADS OR FA DEVICES. IF NEW LIGHT OR DIFFUSER LOCATION DOES NOT WORK WITH EXISTING SPRINKLER/FA DEVICE, PLEASE CONTACT ENGINEER OF RECORD FOR FURTHER DIRECTION. NOTE NEW LIGHTS ARE 3" DEEP. SOME SPRINKLER PIPE ROUTED TIGHT TO THE CEILING MAY NEED TO BE RELOCATED.

DRAWINGS NOTES:

- ① REPLACE GRID W/ NEW 2X2 AS SPECIFIED AND SHOWN.
- ② REPLACE LIGHT FIXTURES IN OFFICES WITH NEW LED FIXTURES MANUFACTURED BY CREE MODEL ZR24-40L-40K-CMA WITH CMC-1 SMARTCAST INTEGRAL MOTION AND AMBIENT SENSORS AND WIRELESS COMMUNICATION. LAMP TYPE 4000 LM 4000K K 90 CRI LED <10% THD DIMMING LED DRIVER 120/277V, 44W LAY -IN MOUNT. RECONNECT TO CIRCUIT SERVING THE AREA AND REPLACE EXISTING SWITCHES WITH CRE NO. CFP-1WN WALL SWITCH WITH WIRELESS DIMMING CAPABILITY TO CONTROL ROOM LIGHTING.
- ③ IN CORRIDOR REPLACE LIGHT FIXTURES WITH NEW LED FIXTURES MANUFACTURED BY CREE MODEL ZR24-40L-40K-CMA WITH CMC-1 SMARTCAST INTEGRAL MOTION AND AMBIENT SENSORS AND WIRELESS COMMUNICATION. LAMP TYPE 4000 LM 4000K K 90 CRI LED <10% THD DIMMING LED DRIVER 120/277V, 44W LAY -IN MOUNT. RECONNECT TO CIRCUIT SERVING THE AREA AND REPLACE EXISTING SWITCHES WITH CRE NO. CFP-1WN WALL SWITCH WITH WIRELESS DIMMING CAPABILITY TO CONTROL ROOM LIGHTING.
- ④ IN LOCATIONS WITH HARD CEILING INSETS REPLACE FIXTURES WITH NEW LED FIXTURES MANUFACTURED BY CREE MODEL S-WR ESSENTIA LED WRAP-40L-40K. INSETS SHALL BE SWITCHED WITH THE HALLWAY IN WHICH IT IS LOCATED. NOTE THESE LIGHTS ARE 3" DEEP.
- ⑤ IN THE CHASES REPLACE THE CURRENT STRIP HUNG FIXTURES WITH NEW LED FIXTURES MANUFACTURED BY CREE MODEL LS4-40L-40K. REPLACE 3-WAY TIMER SWITCH WITH NEW 3-WAY TOGGLE SWITCH.
- ⑥ REPLACE/RELOCATE DOWNLIGHT WITH NEW PORTFOLIO LD6A20-DE010TE-ERMA20-80-40 WITH 3000 LM 4000 K 90 CRI LED <10% THD LED DRIVER 120/277V, 44W RECESSED MOUNTING. RECONNECT TO EXISTING HALLWAY SWITCH.
- ⑦ NO NEW LIGHT FIXTURES SHALL REPLACE WITHIN THE CURRENT LIGHTING TROFFER. REPLACE EXISTING EGGRATE COVER ONCE FIXTURES ARE REMOVED.
- ⑧ ADD AND RELOCATE FIRE ALARM DEVICES AS REQUIRE TO PROVIDE PROPER COVERAGE. PROVIDE SYSTEM PER THE SPECIFICATION.
- ⑨ RELOCATE CEILING DEVICE AS NEEDED.
- ⑩ RELOCATE SPRINKLER HEAD IF NECESSARY TO MATCH RCP.
- ⑪ TWO-PERSON OFFICE. ADD A NEW STROBE.
- ⑫ PROVIDE TWO NEW CIRCUITS FOR CONTROLS POWER FROM THE CHASE. FREE CIRCUITS AT THE TIME OF WALK-THRU ARE:
 GLD1 - 25, 27 & 29 ARE BLANK.
 GLD1 - 21, 23, 25, 26, 28 & 30 ARE BLANK. PROVIDE NEW 20A-IP BREAKER, 24/26 2 POLE OFF.
 GLD2 - 14/16, 18/20, 23/25, 26/28, 27/29 2 POLE SWITCHED OFF.
 35 20A-IP OFF, 7, 9, 11, 15, 17, 23, 24, 32, 36, 38, 40, 41 & 42 ARE BLANK.
 CONTRACTOR MAY PROVIDE CIRCUIT THAT IS MOST CONVENIENT TO THE LOCATION. NOTE CIRCUITS USED ON AS-BUILTS.

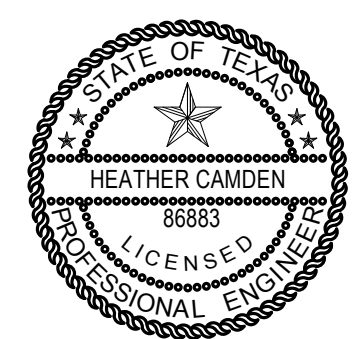
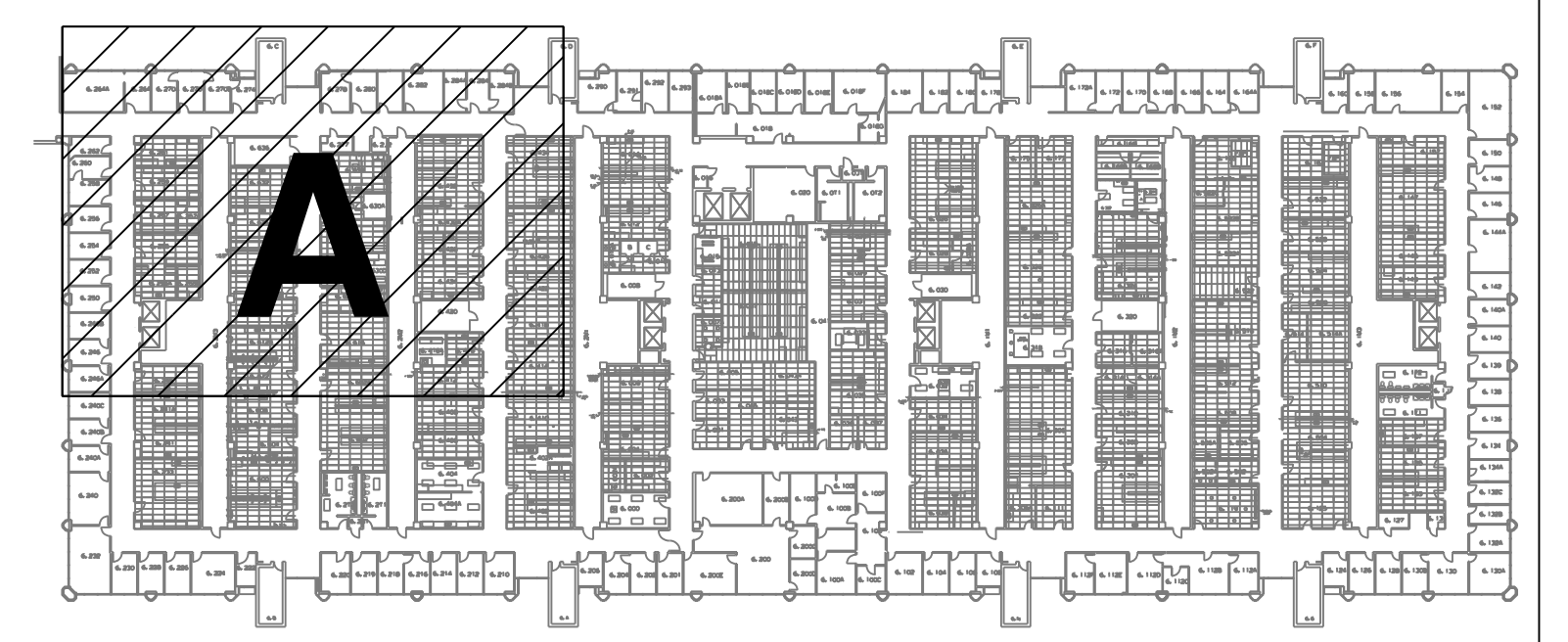

THE SEAL APPEARING ON THIS DRAWING WAS AUTHORIZED BY:
 Digitally signed by Heather Camden
 Date: 2017.03.03 11:00:55-06'00'
 E&C Engineers & Consultants Inc.
 Texas Firm Registration No: F-003068

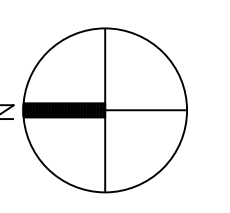

1 ELECTRICAL/CEILING RENO AREA A PLAN
 SCALE: 1/8" = 1' - 0"

**UTHSC
 MSB OFFICE AIR DISTRIBUTION-6TH FLOOR**

E&C
 Engineers & Consultants Inc.
 TX Firm Registration No: F-003068
 1010 Lamar, Suite 650
 Houston, Texas 77002
 Tel 713/580-8800
 Fax 713/580-8888
 www.eceng.com

E&C PROJECT # 3300

SKETCH: RENO AREA A
DRAWING: AE 2.61
REVISION: CONSTRUCTION
SCALE: 1/8"=1'-0"
DATE: 03-03-2017

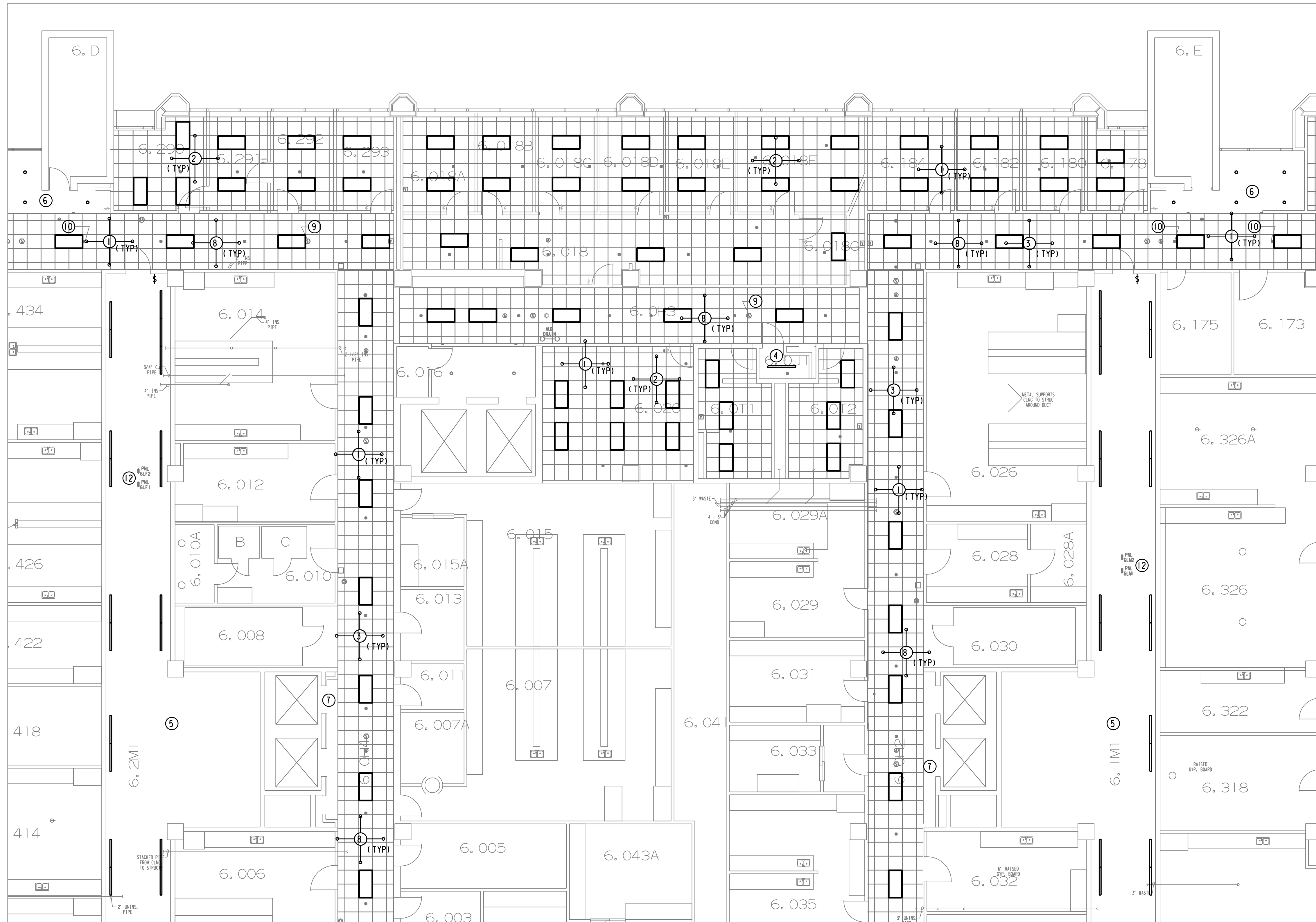

- GENERAL NOTES:**
- A. THE INTENT OF THE DRAWINGS IS NOT TO RELOCATE SPRINKLER HEADS OR FA DEVICES. IF NEW LIGHT OR DIFFUSER LOCATION DOES NOT WORK WITH EXISTING SPRINKLER/FA DEVICE, PLEASE CONTACT ENGINEER OF RECORD FOR FURTHER DIRECTION. NOTE NEW LIGHTS ARE 3" DEEP. SOME SPRINKLER PIPE ROUTED TIGHT TO THE CEILING MAY NEED TO BE RELOCATED.
- DRAWINGS NOTES:**
- REPLACE GRID W/ NEW 2X2 AS SPECIFIED AND SHOWN.
 - REPLACE LIGHT FIXTURES IN OFFICES WITH NEW LED FIXTURES MANUFACTURED BY CREE MODEL ZR24-40L-40K-CMA WITH CMC-1 SMARTCAST INTEGRAL MOTION AND AMBIENT SENSORS AND WIRELESS COMMUNICATION. LAMP TYPE 4000 LM 4000K K 90 CRI LED <10% THD DIMMING LED DRIVER 120/277V, 44W LAY -IN MOUNT. RECONNECT TO CIRCUIT SERVING THE AREA AND REPLACE EXISTING SWITCHES WITH CRE NO. CFP-IWN WALL SWITCH WITH WIRELESS DIMMING CAPABILITY TO CONTROL ROOM LIGHTING.
 - IN CORRIDOR NEW LED FIXTURES MANUFACTURED BY CREE MODEL ZR24-40L-40K-CMA WITH CMC-1 SMARTCAST INTEGRAL MOTION AND AMBIENT SENSORS AND WIRELESS COMMUNICATION. LAMP TYPE 4000 LM 4000K K 90 CRI LED <10% THD DIMMING LED DRIVER 120/277V, 44W LAY -IN MOUNT. RECONNECT TO CIRCUIT SERVING THE AREA AND REPLACE EXISTING SWITCHES WITH CRE NO. CFP-IWN WALL SWITCH WITH WIRELESS DIMMING CAPABILITY TO CONTROL ROOM LIGHTING.
 - IN LOCATIONS WITH HARD CEILING INSETS REPLACE FIXTURES WITH NEW LED FIXTURES MANUFACTURED BY CREE MODEL S-WR ESSENTIA LED WRAP-40L-40K. INSETS SHALL BE SWITCHED WITH THE HALLWAY IN WHICH IT IS LOCATED. NOTE 3" DEEP FIXTURE.
 - IN THE CHASES REPLACE THE CURRENT STRIP HUNG FIXTURES WITH NEW LED FIXTURES MANUFACTURED BY CREE MODEL LS4-40L-40K. REPLACE 3-WAY TIMER SWITCH WITH NEW 3-WAY TOGGLE SWITCH.
 - REPLACE/RELOCATE DOWNLIGHT WITH NEW PORTFOLIO LD6A20-DEIOTE-ERMA20-80-40 WITH 3000 LM 4000 K 90 CRI LED <10% THD LED DRIVER 120/277V, 44W RECESSED MOUNTING. RECONNECT TO EXISTING HALLWAY SWITCH.
 - NO NEW LIGHT FIXTURES SHALL REPLACE WITHIN THE CURRENT LIGHTING TROFFER. REPLACE EXISTING EGGRATE COVER ONCE FIXTURES ARE REMOVED.
 - ADD AND RELOCATE FIRE ALARM DEVICES AS REQUIRE TO PROVIDE PROPER COVERAGE. PROVIDE SYSTEM PER THE SPECIFICATION.
 - RELOCATE CEILING DEVICE AS NEEDED.
 - RELOCATE SPRINKLER HEAD IF NECESSARY TO MATCH RCP.
 - TWO-PERSON OFFICE. ADD A NEW STROBE.
 - PROVIDE TWO NEW CIRCUITS FOR CONTROLS POWER FROM THE CHASE. FREE CIRCUITS AT THE TIME OF WALK-THRU ARE:
6LF1 - 1, 3, 5, 7, 14, 16, 18, 26 & 36 ARE BLANK.
6LF2 - 24 IS BLANK.
6LM1 - NO AVAILABLE CIRCUITS.
6LM2 - 26/28/30 3 POLE REPLACE WITH 20A-1P BREAKERS.
CONTRACTOR MAY PROVIDE CIRCUIT THAT IS MOST CONVENIENT TO THE LOCATION. NOTE CIRCUITS USED ON AS-BUILTS.

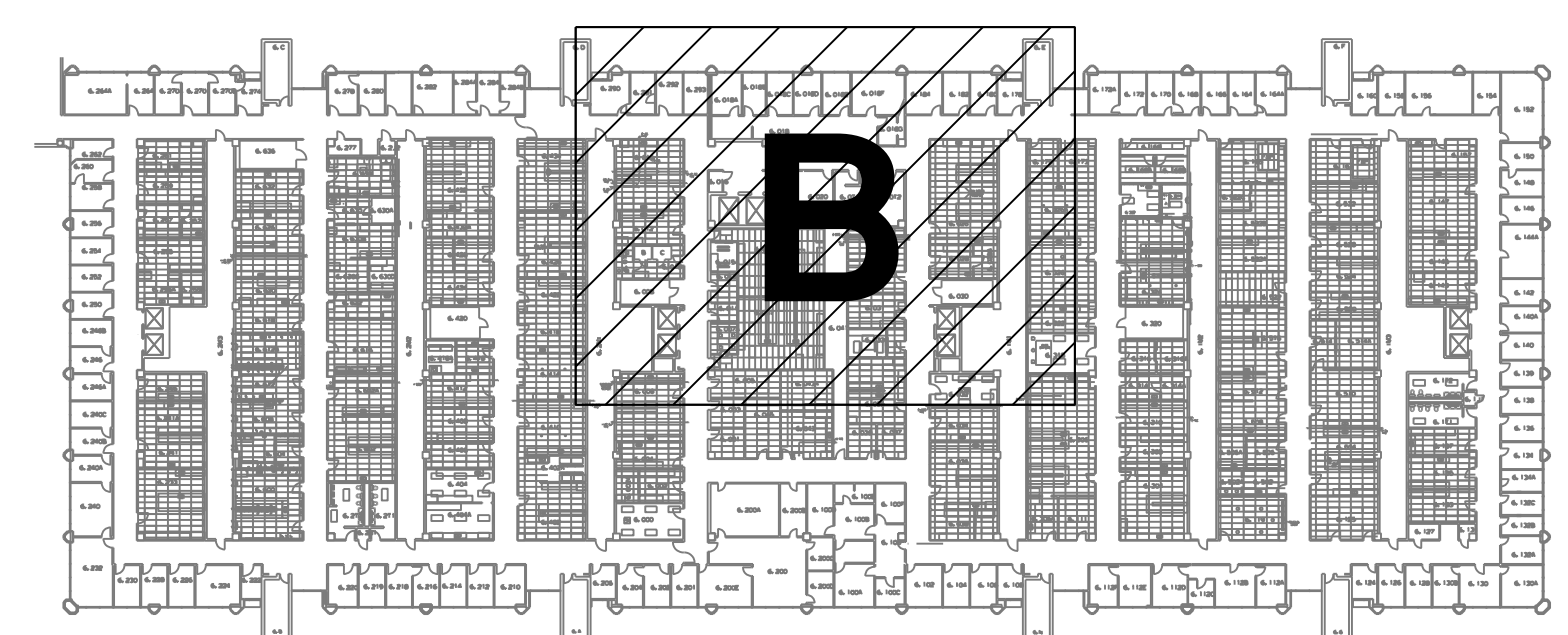

1 ARCH/LIGHTING RENO AREA B PLAN
SCALE: 1/8" = 1'-0"

THE SEAL APPEARING ON THIS DRAWING WAS AUTHORIZED BY:
Digitally signed by Heather Camden
Date: 2017.03.03 11:00:55-06'00'
E&C Engineers & Consultants Inc.
Texas Firm Registration No: F-003068

**UTHSC
MSB OFFICE AIR DISTRIBUTION-6TH FLOOR**

E&C PROJECT # 3300

E&C
Engineers & Consultants Inc.
TX Firm Registration No: F-003068
1010 Lamar, Suite 650
Houston, Texas 77002
Tel 713/580-8800
Fax 713/580-8888
www.eceng.com

SKETCH: RENO AREA B
DRAWING: AE 2.62
REVISION: CONSTRUCTION
SCALE: 1/8"=1'-0"
DATE: 03-03-2017

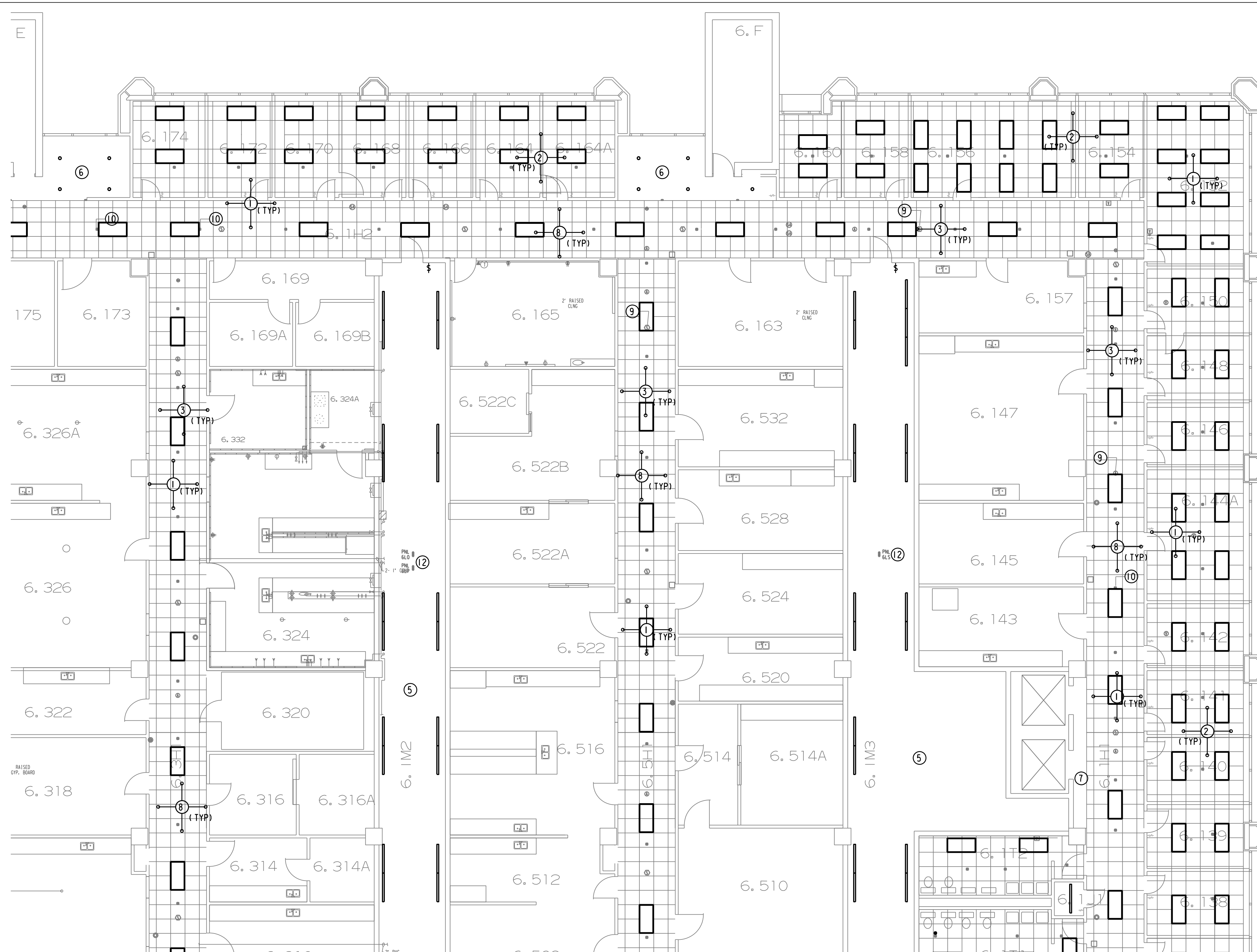

GENERAL NOTES:

A. THE INTENT OF THE DRAWINGS IS NOT TO RELOCATE SPRINKLER HEADS OR FA DEVICES. IF NEW LIGHT OR DIFFUSER LOCATION DOES NOT WORK WITH EXISTING SPRINKLER/FA DEVICE, PLEASE CONTACT ENGINEER OF RECORD FOR FURTHER DIRECTION. NOTE NEW LIGHTS ARE 3" DEEP. SOME SPRINKLER PIPE ROUTED TIGHT TO THE CEILING MAY NEED TO BE RELOCATED.

DRAWINGS NOTES:

- ① REPLACE GRID W/ NEW 2X2 AS SPECIFIED AND SHOWN.
- ② REPLACE LIGHT FIXTURES IN OFFICES WITH NEW LED FIXTURES MANUFACTURED BY CREE MODEL ZR24-40L-40K-CMA WITH CMC-1 SMARTCAST INTEGRAL MOTION AND AMBIENT SENSORS AND WIRELESS COMMUNICATION. LAMP TYPE 4000 LM 4000K K 90 CRI LED <10% THD DIMMING LED DRIVER 120/277V, 44W LAY -IN MOUNT. RECONNECT TO CIRCUIT SERVING THE AREA AND REPLACE EXISTING SWITCHES WITH CRE NO. CFP-IWN WALL SWITCH WITH WIRELESS DIMMING CAPABILITY TO CONTROL ROOM LIGHTING.
- ③ IN CORRIDOR REPLACE LIGHT FIXTURES WITH NEW LED FIXTURES MANUFACTURED BY CREE MODEL ZR24-40L-40K-CMA WITH CMC-1 SMARTCAST INTEGRAL MOTION AND AMBIENT SENSORS AND WIRELESS COMMUNICATION. LAMP TYPE 4000 LM 4000K K 90 CRI LED <10% THD DIMMING LED DRIVER 120/277V, 44W LAY -IN MOUNT. RECONNECT TO CIRCUIT SERVING THE AREA AND REPLACE EXISTING SWITCHES WITH CRE NO. CFP-IWN WALL SWITCH WITH WIRELESS DIMMING CAPABILITY TO CONTROL ROOM LIGHTING.
- ④ IN LOCATIONS WITH HARD CEILING INSETS REPLACE FIXTURES WITH NEW LED FIXTURES MANUFACTURED BY CREE MODEL S-WR ESSENTIA LED WRAP-40L-40K. INSETS SHALL BE SWITCHED WITH THE HALLWAY IN WHICH IT IS LOCATED. NOTE 3" DEEP FIXTURE.
- ⑤ IN THE CHASES REPLACE THE CURRENT STRIP HUNG FIXTURES WITH NEW LED FIXTURES MANUFACTURED BY CREE MODEL LS4-40L-40K. REPLACE 3-WAY TIMER SWITCH WITH NEW 3-WAY TOGGLE SWITCH.
- ⑥ REPLACE/RELOCATE DOWNLIGHT WITH NEW PORTFOLIO LD6A20-DE010TE-ERMA20-80-40 WITH 3000 LM 4000 K 90 CRI LED <10% THD LED DRIVER 120/277V, 44W RECESSED MOUNTING. RECONNECT TO EXISTING HALLWAY SWITCH.
- ⑦ NO NEW LIGHT FIXTURES SHALL REPLACE WITHIN THE CURRENT LIGHTING TROFFER. REPLACE EXISTING EGGRATE COVER ONCE FIXTURES ARE REMOVED.
- ⑧ ADD AND RELOCATE FIRE ALARM DEVICES AS REQUIRED TO PROVIDE PROPER COVERAGE. PROVIDE SYSTEM PER THE SPECIFICATION.
- ⑨ RELOCATE CEILING DEVICE AS NEEDED.
- ⑩ RELOCATE SPRINKLER HEAD IF NECESSARY TO MATCH RCP.
- ⑪ TWO-PERSON OFFICE. ADD A NEW STROBE.
- ⑫ PROVIDE TWO NEW CIRCUITS FOR CONTROLS POWER FROM THE CHASE. FREE CIRCUITS AT THE TIME OF WALK-THRU ARE:
 6LP - 16, 17, 18, 32, 33, 34 & 36 20A-1P OFF, 26/28/30 3 POLE OFF CAN BE REPLACED WITH 3 20A-1P BREAKERS, 20, 22, 24, 35, 37, 38, 39, 40, 41 & 42 ARE SPACES.
 6LO - ISOLATED PANEL. DO NOT USE.
 6LS - 25, 26, 27, 28, 29 & 30 ARE SPACES.
 CONTRACTOR MAY PROVIDE CIRCUIT THAT IS MOST CONVENIENT TO THE LOCATION. NOTE CIRCUITS USED ON AS-BUILTS.

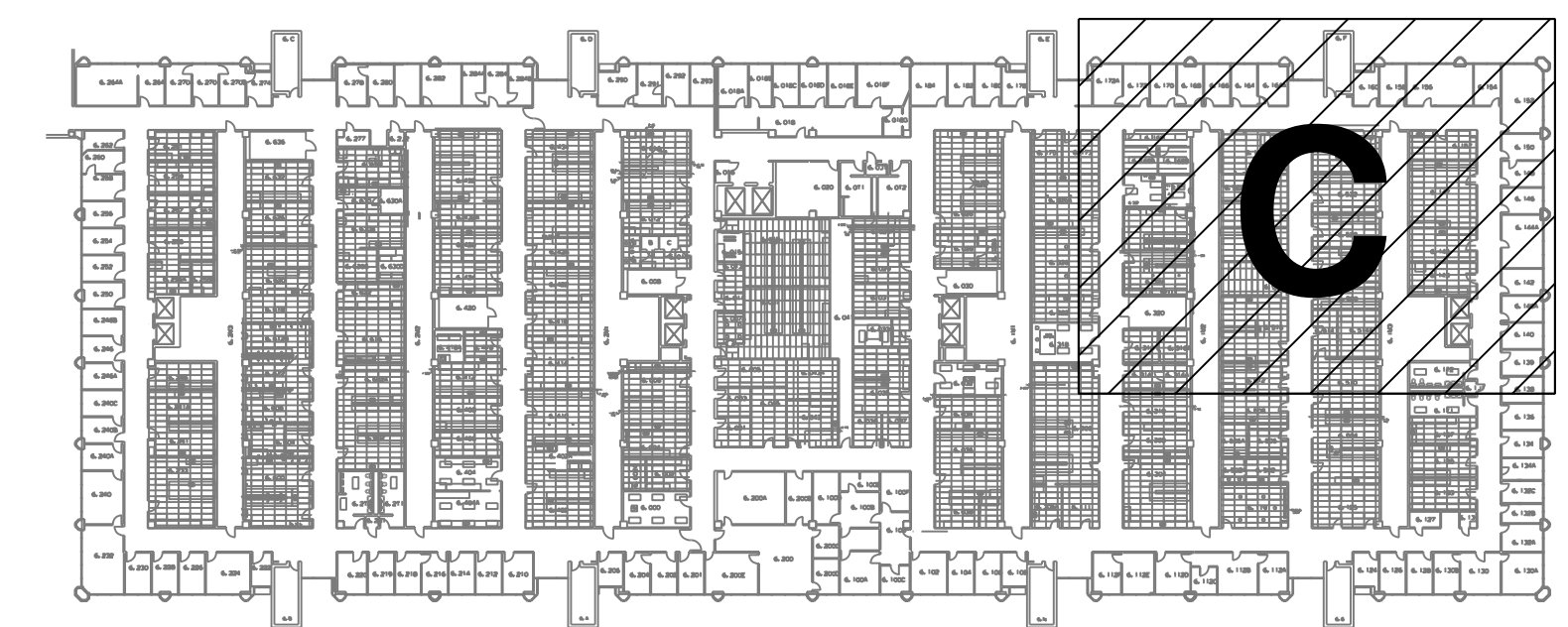

1 ARCH/LIGHTING RENO AREA C PLAN
 SCALE: 1/8" = 1'-0"

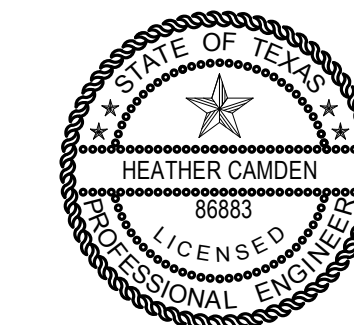

THE SEAL APPEARING ON THIS DRAWING WAS AUTHORIZED BY:
 Digitally signed by Heather Camden
 Date: 2017.03.03 11:00:55-06'00'
 E&C Engineers & Consultants Inc.
 Texas Firm Registration No: F-003068

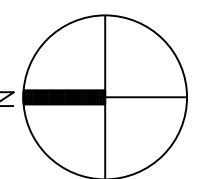

E&C
 Engineers & Consultants Inc.
 TX Firm Registration No: F-003068
 1010 Lamar, Suite 650
 Houston, Texas 77002
 Tel 713/580-8800
 Fax 713/580-8888
 www.eceng.com

**UTHSC
 MSB OFFICE AIR DISTRIBUTION-6TH FLOOR**

E&C PROJECT # 3300

**SKETCH: RENO AREA C
 DRAWING: AE 2.63
 REVISION: CONSTRUCTION
 SCALE: 1/8"=1'-0"
 DATE: 03-03-2017**

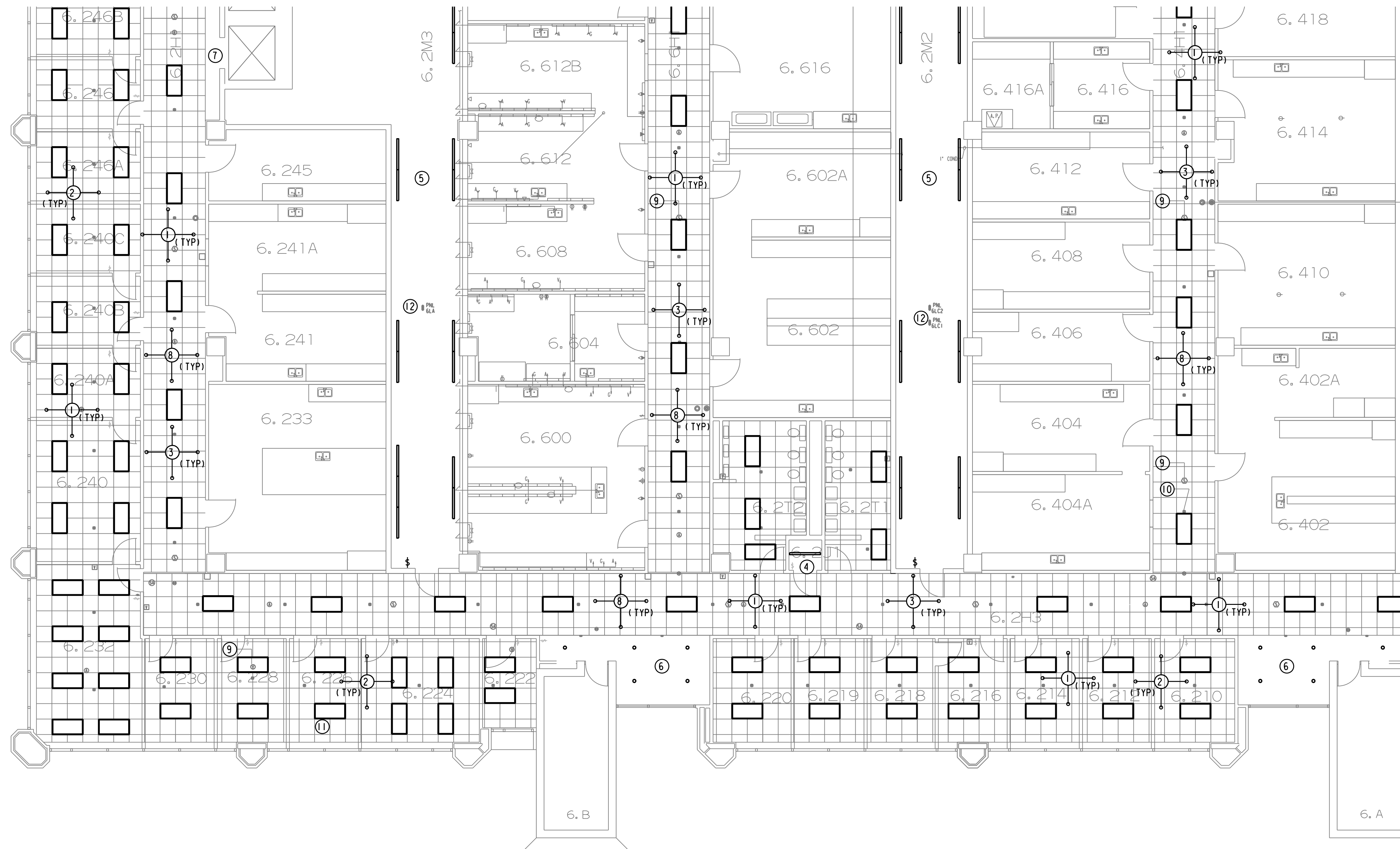

GENERAL NOTES:

A. THE INTENT OF THE DRAWINGS IS NOT TO RELOCATE SPRINKLER HEADS OR FA DEVICES. IF NEW LIGHT OR DIFFUSER LOCATION DOES NOT WORK WITH EXISTING SPRINKLER/FA DEVICE, PLEASE CONTACT ENGINEER OF RECORD FOR FURTHER DIRECTION. NOTE NEW LIGHTS ARE 3" DEEP. SOME SPRINKLER PIPE ROUTED TIGHT TO THE CEILING MAY NEED TO BE RELOCATED.

DRAWINGS NOTES:

- ① REPLACE GRID W/ NEW 2X2 AS SPECIFIED AND SHOWN.
- ② REPLACE LIGHT FIXTURES IN OFFICES WITH NEW LED FIXTURES MANUFACTURED BY CREE MODEL ZR24-40L-40K-CMA WITH CMC-1 SMARTCAST INTEGRAL MOTION AND AMBIENT SENSORS AND WIRELESS COMMUNICATION. LAMP TYPE 4000 LM 4000K K 90 CRI LED <10% THD DIMMING LED DRIVER 120/277V, 44W LAY -IN MOUNT. RECONNECT TO CIRCUIT SERVING THE AREA AND REPLACE EXISTING SWITCHES WITH CRE NO. CFP-IWN WALL SWITCH WITH WIRELESS DIMMING CAPABILITY TO CONTROL ROOM LIGHTING.
- ③ IN CORRIDOR REPLACE LIGHT FIXTURES WITH NEW LED FIXTURES MANUFACTURED BY CREE MODEL ZR24-40L-40K-CMA WITH CMC-1 SMARTCAST INTEGRAL MOTION AND AMBIENT SENSORS AND WIRELESS COMMUNICATION. LAMP TYPE 4000 LM 4000K K 90 CRI LED <10% THD DIMMING LED DRIVER 120/277V, 44W LAY -IN MOUNT. RECONNECT TO CIRCUIT SERVING THE AREA AND REPLACE EXISTING SWITCHES WITH CRE NO. CFP-IWN WALL SWITCH WITH WIRELESS DIMMING CAPABILITY TO CONTROL ROOM LIGHTING.
- ④ IN LOCATIONS WITH HARD CEILING INSERTS REPLACE FIXTURES WITH NEW LED FIXTURES MANUFACTURED BY CREE MODEL S-WR ESSENTIA LED WRAP-40L-40K. INSERTS SHALL BE SWITCHED WITH THE HALLWAY IN WHICH IT IS LOCATED. NOTE 3" DEEP FIXTURE.
- ⑤ IN THE CHASES REPLACE THE CURRENT STRIP HUNG FIXTURES WITH NEW LED FIXTURES MANUFACTURED BY CREE MODEL LS4-40L-40K. REPLACE 3-WAY TIMER SWITCH WITH NEW 3-WAY TOGGLE SWITCH.
- ⑥ REPLACE/RELOCATE DOWNLIGHT WITH NEW PORTFOLIO LD6A20-DE010TE-ERMA20-80-40 WITH 3000 LM 4000 K 90 CRI LED <10% THD LED DRIVER 120/277V, 44W RECESSED MOUNTING. RECONNECT TO EXISTING HALLWAY SWITCH.
- ⑦ NO NEW LIGHT FIXTURES SHALL REPLACE WITHIN THE CURRENT LIGHTING TROFFER. REPLACE EXISTING EGGRATE COVER ONCE FIXTURES ARE REMOVED.
- ⑧ ADD AND RELOCATE FIRE ALARM DEVICES AS REQUIRE TO PROVIDE PROPER COVERAGE. PROVIDE SYSTEM PER THE SPECIFICATION.
- ⑨ RELOCATE CEILING DEVICE AS NEEDED.
- ⑩ RELOCATE SPRINKLER HEAD IF NECESSARY TO MATCH RCP.
- ⑪ TWO-PERSON OFFICE. ADD A NEW STROBE.
- ⑫ PROVIDE TWO NEW CIRCUITS FOR CONTROLS POWER FROM THE CHASE. FREE CIRCUITS AT THE TIME OF WALK-THRU ARE:
 6LA - 19/21 - 2 POLE OFF, 29 & 30 ARE SPACES.
 6LC1 - 4/6 2 POLE OFF, 15/17/19 & 16/18/20 3 POLE OFF
 2, 8 & 22 20A-1P OFF.
 1, 3, 5, 10, 12, 24, 26, 31, 32, 33, 34, 35 & 36 SPARE
 6LC2 - 21 & 23 20A-1P OFF, 18/20/22 3 POLE OFF.
 CONTRACTOR MAY PROVIDE CIRCUIT THAT IS MOST CONVENIENT TO THE LOCATION. NOTE CIRCUITS USED ON AS-BUILTS.

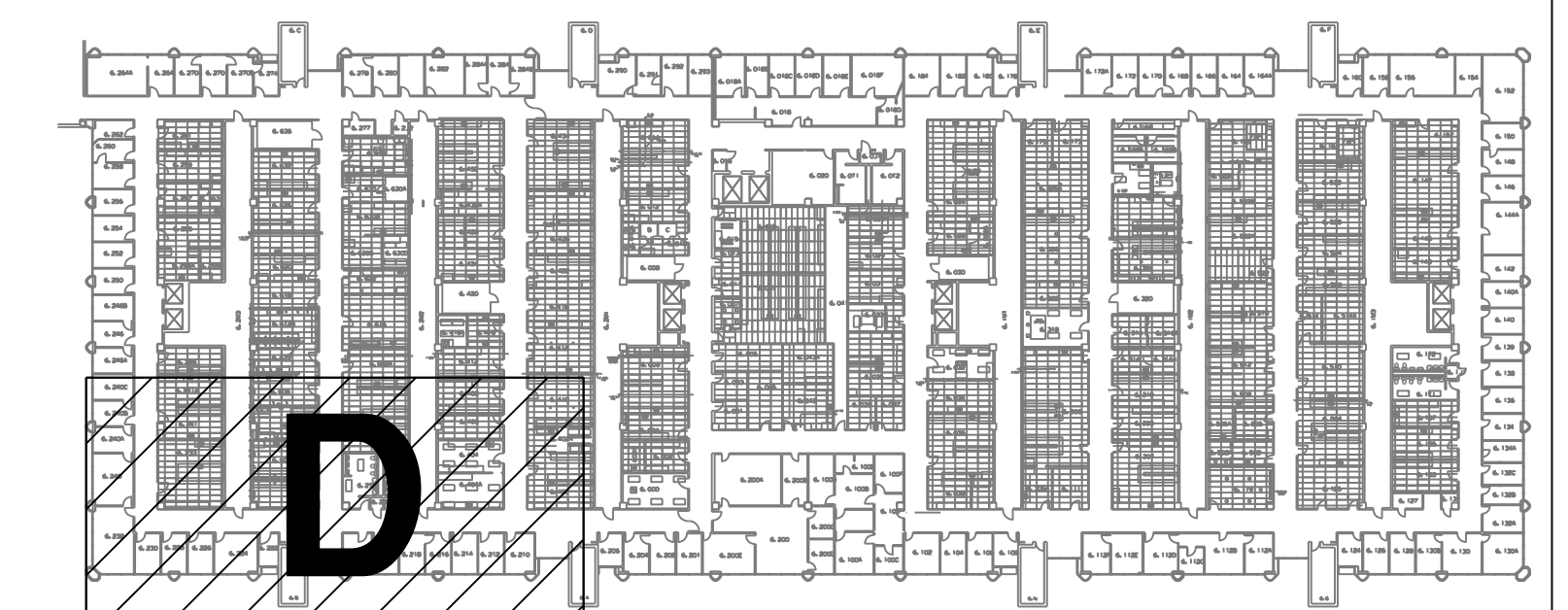

1 ARCH/LIGHTING RENO AREA D PLAN
 SCALE: 1/8" = 1' - 0"

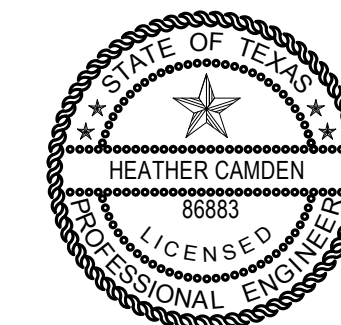

THE SEAL APPEARING ON THIS DRAWING WAS AUTHORIZED BY:
 Digitally signed by Heather Camden
 Date: 2017.03.03 11:00:55-06'00"
 E&C Engineers & Consultants Inc.
 Texas Firm Registration No: F-003068

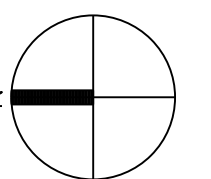

E&C
 Engineers & Consultants Inc.
 TX Firm Registration No: F-003068
 1010 Lamar, Suite 650
 Houston, Texas 77002
 Tel 713/580-8800
 Fax 713/580-8888
 www.eceng.com

**UTHSC
 MSB OFFICE AIR DISTRIBUTION-6TH FLOOR**

E&C PROJECT # 3300

SKETCH: RENO AREA D
 DRAWING: AE 2.64
 REVISION: CONSTRUCTION
 SCALE: 1/8"=1'-0"
 DATE: 03-03-2017

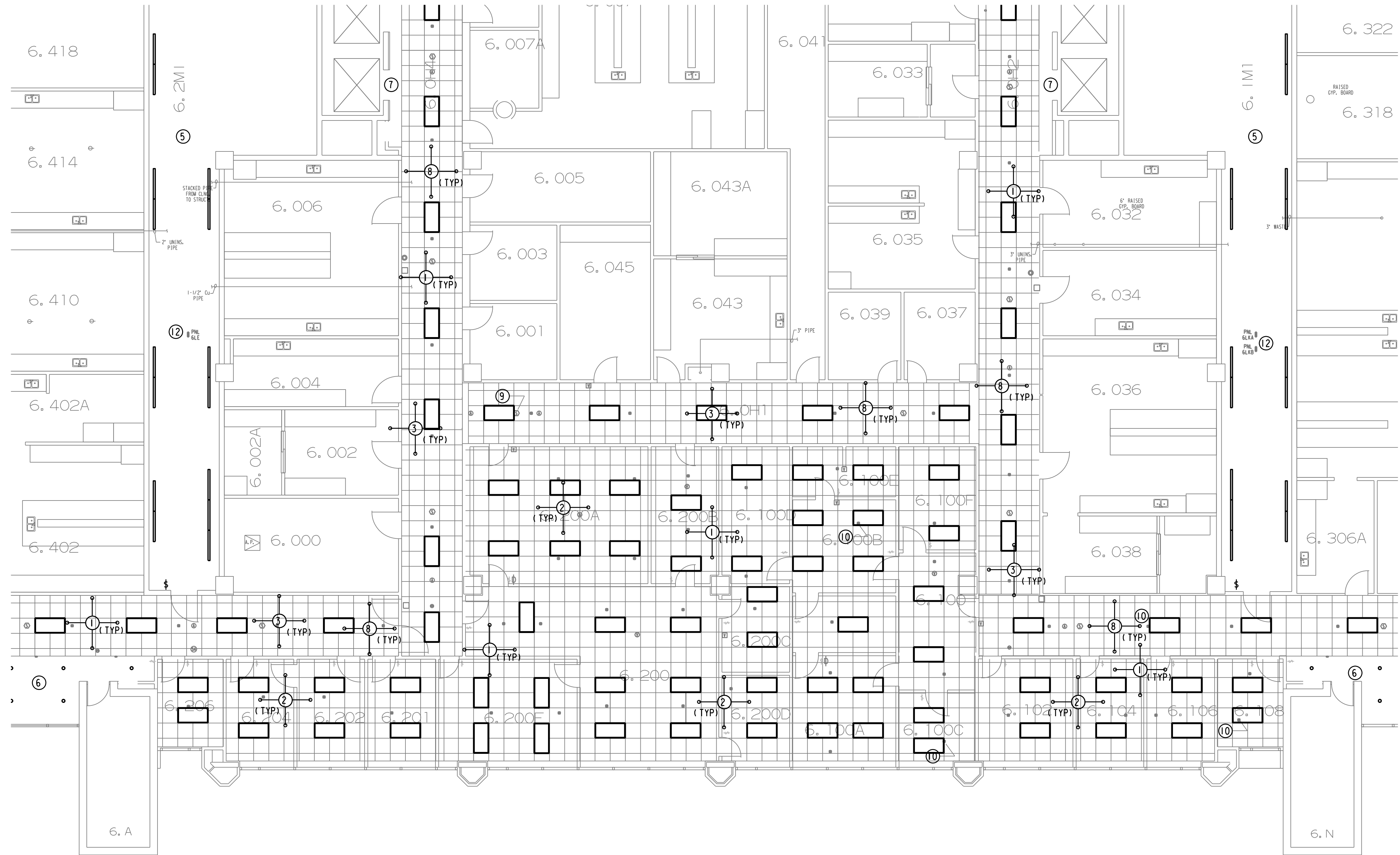

GENERAL NOTES:

A. THE INTENT OF THE DRAWINGS IS NOT TO RELOCATE SPRINKLER HEADS OR FA DEVICES. IF NEW LIGHT OR DIFFUSER LOCATION DOES NOT WORK WITH EXISTING SPRINKLER/FA DEVICE, PLEASE CONTACT ENGINEER OF RECORD FOR FURTHER DIRECTION. NOTE NEW LIGHTS ARE 3" DEEP. SOME SPRINKLER PIPE ROUTED TIGHT TO THE CEILING MAY NEED TO BE RELOCATED.

DRAWINGS NOTES:

- ① REPLACE GRID W/ NEW 2X2 AS SPECIFIED AND SHOWN.
- ② REPLACE LIGHT FIXTURES IN OFFICES WITH NEW LED FIXTURES MANUFACTURED BY CREE MODEL ZR24-40L-40K-CMA WITH CMC-1 SMARTCAST INTEGRAL MOTION AND AMBIENT SENSORS AND WIRELESS COMMUNICATION. LAMP TYPE 4000 LM 4000K K 90 CRI LED <10% THD DIMMING LED DRIVER 120/277V, 4W LAY -IN MOUNT. RECONNECT TO CIRCUIT SERVING THE AREA AND REPLACE EXISTING SWITCHES WITH CRE NO. CFP-IWN WALL SWITCH WITH WIRELESS DIMMING CAPABILITY TO CONTROL ROOM LIGHTING.
- ③ IN CORRIDOR REPLACE LIGHT FIXTURES WITH NEW LED FIXTURES MANUFACTURED BY CREE MODEL ZR24-40L-40K-CMA WITH CMC-1 SMARTCAST INTEGRAL MOTION AND AMBIENT SENSORS AND WIRELESS COMMUNICATION. LAMP TYPE 4000 LM 4000K K 90 CRI LED <10% THD DIMMING LED DRIVER 120/277V, 4W LAY -IN MOUNT. RECONNECT TO CIRCUIT SERVING THE AREA AND REPLACE EXISTING SWITCHES WITH CRE NO. CFP-IWN WALL SWITCH WITH WIRELESS DIMMING CAPABILITY TO CONTROL ROOM LIGHTING.
- ④ IN LOCATIONS WITH HARD CEILING INSERTS REPLACE FIXTURES WITH NEW LED FIXTURES MANUFACTURED BY CREE MODEL S-WR ESSENTIA LED WRAP-40L-40K. INSERTS SHALL BE SWITCHED WITH THE HALLWAY IN WHICH IT IS LOCATED. NOTE 3" DEEP FIXTURE.
- ⑤ IN THE CHASES REPLACE THE CURRENT STRIP HUNG FIXTURES WITH NEW LED FIXTURES MANUFACTURED BY CREE MODEL LS4-40L-40K. REPLACE 3-WAY TIMER SWITCH WITH NEW 3-WAY TOGGLE SWITCH.
- ⑥ REPLACE/RELOCATE DOWNLIGHT WITH NEW PORTFOLIO LD6A20-DE010TE-ERMA20-80-40 WITH 3000 LM 4000 K 90 CRI LED <10% THD LED DRIVER 120/277V, 44W RECESSED MOUNTING. RECONNECT TO EXISTING HALLWAY SWITCH.
- ⑦ NO NEW LIGHT FIXTURES SHALL REPLACE WITHIN THE CURRENT LIGHTING TROFFER. REPLACE EXISTING EGGRATE COVER ONCE FIXTURES ARE REMOVED.
- ⑧ ADD AND RELOCATE FIRE ALARM DEVICES AS REQUIRED TO PROVIDE PROPER COVERAGE. PROVIDE SYSTEM PER THE SPECIFICATION.
- ⑨ RELOCATE CEILING DEVICE AS NEEDED.
- ⑩ RELOCATE SPRINKLER HEAD IF NECESSARY TO MATCH RCP.
- ⑪ TWO-PERSON OFFICE. ADD A NEW STROBE.
- ⑫ PROVIDE TWO NEW CIRCUITS FOR CONTROLS POWER FROM THE CHASE. FREE CIRCUITS AT THE TIME OF WALK-THRU ARE:
6LE1 - 27, 28, 29 & 30 ARE BLANK.
6LKA - NO AVAILABLE CIRCUITS.
6LKB - 31-42 BLANK.
CONTRACTOR MAY PROVIDE CIRCUIT THAT IS MOST CONVENIENT TO THE LOCATION. NOTE CIRCUITS USED ON AS-BUILTS.

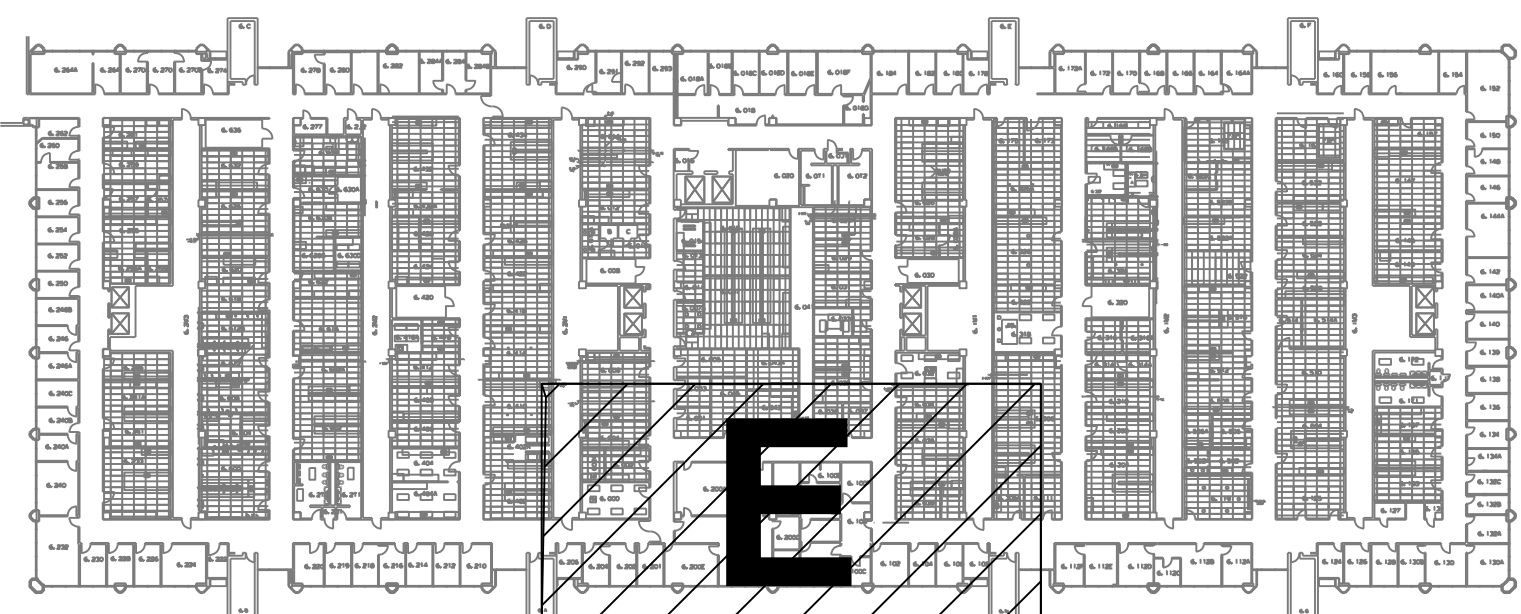

1 ARCH/LIGHTING RENO AREA E PLAN
SCALE: 1/8" = 1' - 0"

E&C
Engineers & Consultants Inc.
TX Firm Registration No: F-003068
1010 Lamar, Suite 650
Houston, Texas 77002
Tel 713/580-8800
Fax 713/580-8888
www.eceng.com

**UTHSC
MSB OFFICE AIR DISTRIBUTION-6TH FLOOR**

E&C PROJECT # 3300

THE SEAL APPEARING ON THIS DRAWING WAS AUTHORIZED BY:
Digitally signed
by Heather
Camden
Date: 2017.03.03
11:00:55-06'00'
E&C Engineers & Consultants Inc.
Texas Firm Registration No: F-003068

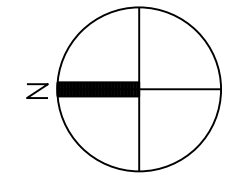

SKETCH: RENO AREA E
DRAWING: AE 2.65
REVISION: CONSTRUCTION
SCALE: 1/8"=1'-0"
DATE: 03-03-2017

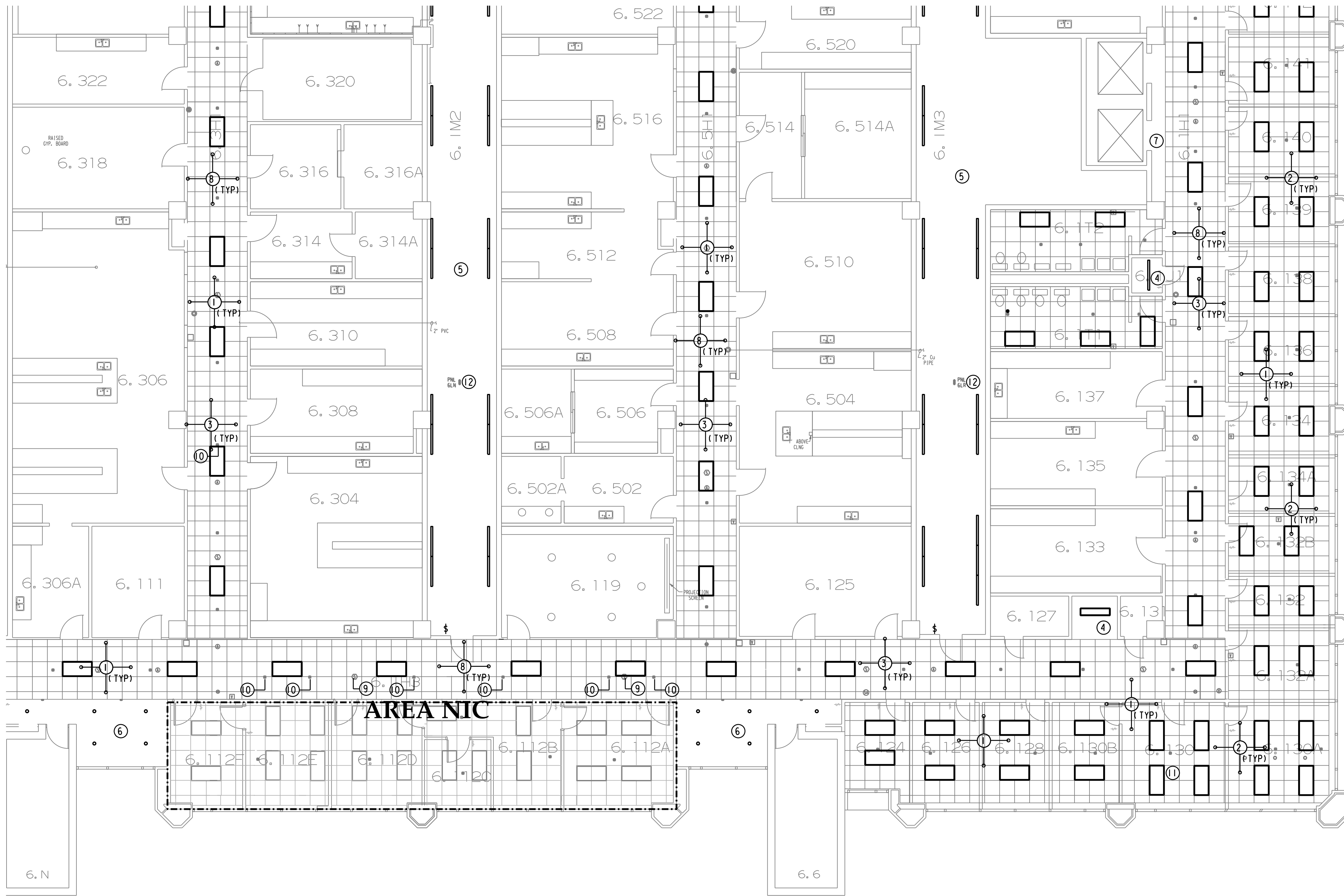

GENERAL NOTES:

A. THE INTENT OF THE DRAWINGS IS NOT TO RELOCATE SPRINKLER HEADS OR FA DEVICES. IF NEW LIGHT OR DIFFUSER LOCATION DOES NOT WORK WITH EXISTING SPRINKLER/FA DEVICE, PLEASE CONTACT ENGINEER OF RECORD FOR FURTHER DIRECTION. NOTE NEW LIGHTS ARE 3" DEEP. SOME SPRINKLER PIPE ROUTED TIGHT TO THE CEILING MAY NEED TO BE RELOCATED.

DRAWINGS NOTES:

- ① REPLACE GRID W/ NEW 2X2 AS SPECIFIED AND SHOWN.
- ② REPLACE LIGHT FIXTURES IN OFFICES WITH NEW LED FIXTURES MANUFACTURED BY CREE MODEL ZR24-40L-40K-CMA WITH CMC-1 SMARTCAST INTEGRAL MOTION AND AMBIENT SENSORS AND WIRELESS COMMUNICATION. LAMP TYPE 4000 LM 4000K K 90 CRI LED <10% THD DIMMING LED DRIVER 120/277V, 44W LAY -IN MOUNT. RECONNECT TO CIRCUIT SERVING THE AREA AND REPLACE EXISTING SWITCHES WITH CRE NO. CFP-1WN WALL SWITCH WITH WIRELESS DIMMING CAPABILITY TO CONTROL ROOM LIGHTING.
- ③ IN CORRIDOR NEW LED FIXTURES MANUFACTURED BY CREE MODEL ZR24-40L-40K-CMA WITH CMC-1 SMARTCAST INTEGRAL MOTION AND AMBIENT SENSORS AND WIRELESS COMMUNICATION. LAMP TYPE 4000 LM 4000K K 90 CRI LED <10% THD DIMMING LED DRIVER 120/277V, 44W LAY -IN MOUNT. RECONNECT TO CIRCUIT SERVING THE AREA AND REPLACE EXISTING SWITCHES WITH CRE NO. CFP-1WN WALL SWITCH WITH WIRELESS DIMMING CAPABILITY TO CONTROL ROOM LIGHTING.
- ④ IN LOCATIONS WITH HARD CEILING INSERTS REPLACE FIXTURES WITH NEW LED FIXTURES MANUFACTURED BY CREE MODEL S-WR ESSENTIA LED WRAP-40L-40K. INSERTS SHALL BE SWITCHED WITH THE HALLWAY IN WHICH IT IS LOCATED. NOTE 3" DEEP FIXTURE.
- ⑤ IN THE CHASES REPLACE THE CURRENT STRIP HUNG FIXTURES WITH NEW LED FIXTURES MANUFACTURED BY CREE MODEL LS4-40L-40K. REPLACE 3-WAY TIMER SWITCH WITH NEW 3-WAY TOGGLE SWITCH.
- ⑥ REPLACE/RELOCATE DOWNLIGHT WITH NEW PORTFOLIO LD6A20-DEIOTE-ERMA20-80-40 WITH 3000 LM 4000 K 90 CRI LED <10% THD LED DRIVER 120/277V, 44W RECESSED MOUNTING. RECONNECT TO EXISTING HALLWAY SWITCH.
- ⑦ NO NEW LIGHT FIXTURES SHALL REPLACE WITHIN THE CURRENT LIGHTING TROFFER. REPLACE EXISTING EGGRATE COVER ONCE FIXTURES ARE REMOVED.
- ⑧ ADD AND RELOCATE FIRE ALARM DEVICES AS REQUIRE TO PROVIDE PROPER COVERAGE. PROVIDE SYSTEM PER THE SPECIFICATION.
- ⑨ RELOCATE CEILING DEVICE AS NEEDED.
- ⑩ RELOCATE SPRINKLER HEAD IF NECESSARY TO MATCH RCP.
- ⑪ TWO-PERSON OFFICE. ADD A NEW STROBE.
- ⑫ PROVIDE TWO NEW CIRCUITS FOR CONTROLS POWER FROM THE CHASE. FREE CIRCUITS AT THE TIME OF WALK-THRU ARE:
 6LN - 14 - 20A-1P OFF, 20/22 2 POLE OFF, 23 BLANK
 6LR - 28/30/32 - 3 POLE OFF, 40/42 - 2 POLE OFF.
 CONTRACTOR MAY PROVIDE CIRCUIT THAT IS MOST CONVENIENT TO THE LOCATION. NOTE CIRCUITS USED ON AS-BUILTS.

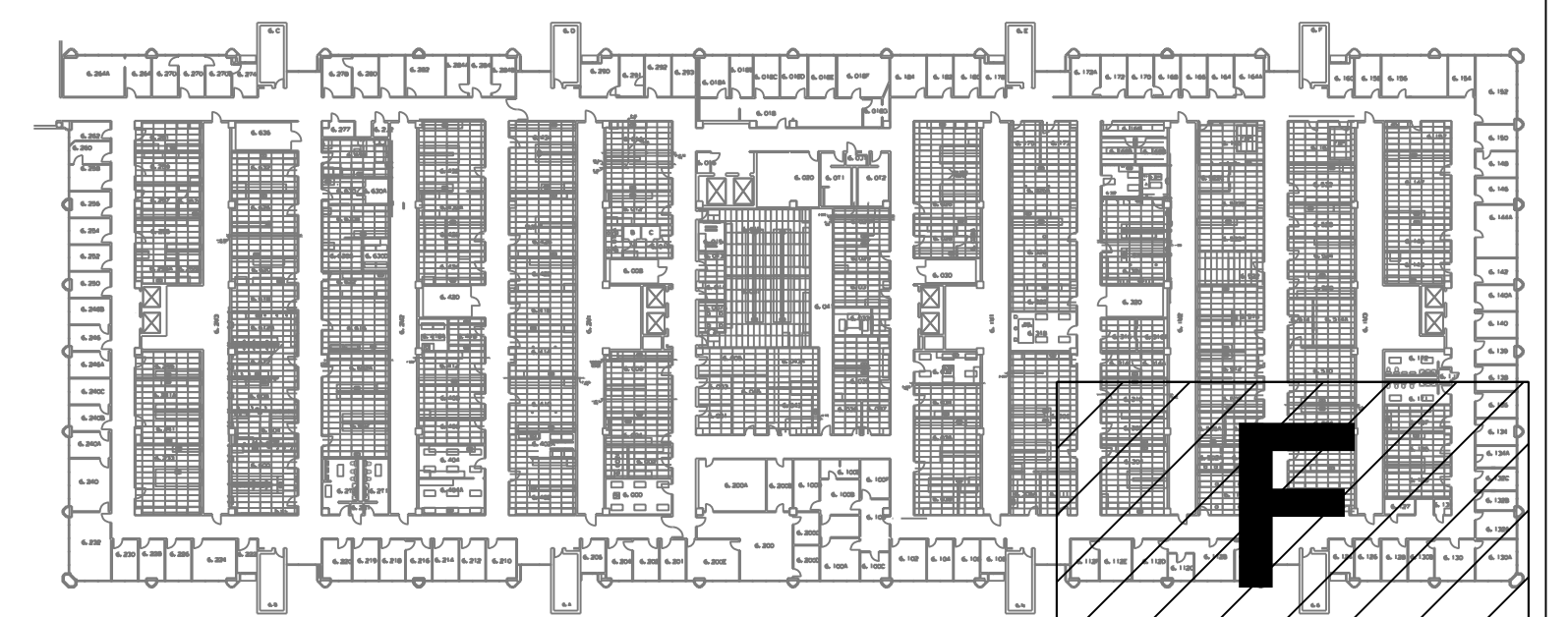

1 ARCH/LIGHTING RENO AREA F PLAN
 SCALE: 1/8" = 1'-0"

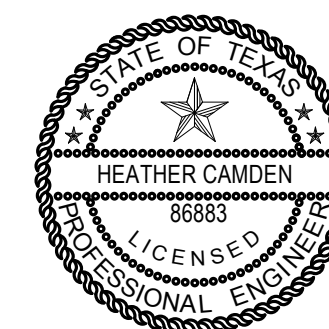

THE SEAL APPEARING ON THIS DRAWING WAS AUTHORIZED BY:
 Digitally signed by Heather Camden
 Date: 2017.03.03 11:00:55-06'00'
 E&C Engineers & Consultants Inc.
 Texas Firm Registration No: F-003068

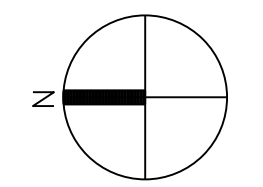

E&C
 Engineers & Consultants Inc.
 TX Firm Registration No: F-003068
 1010 Lamar, Suite 650
 Houston, Texas 77002
 Tel 713/580-8800
 Fax 713/580-8888
 www.eceng.com

**UTHSC
 MSB OFFICE AIR DISTRIBUTION-6TH FLOOR**

E&C PROJECT # 3300

SKETCH: RENO AREA F
DRAWING: AE 2.66
REVISION: CONSTRUCTION
SCALE: 1/8"=1'-0"
DATE: 03-03-2017

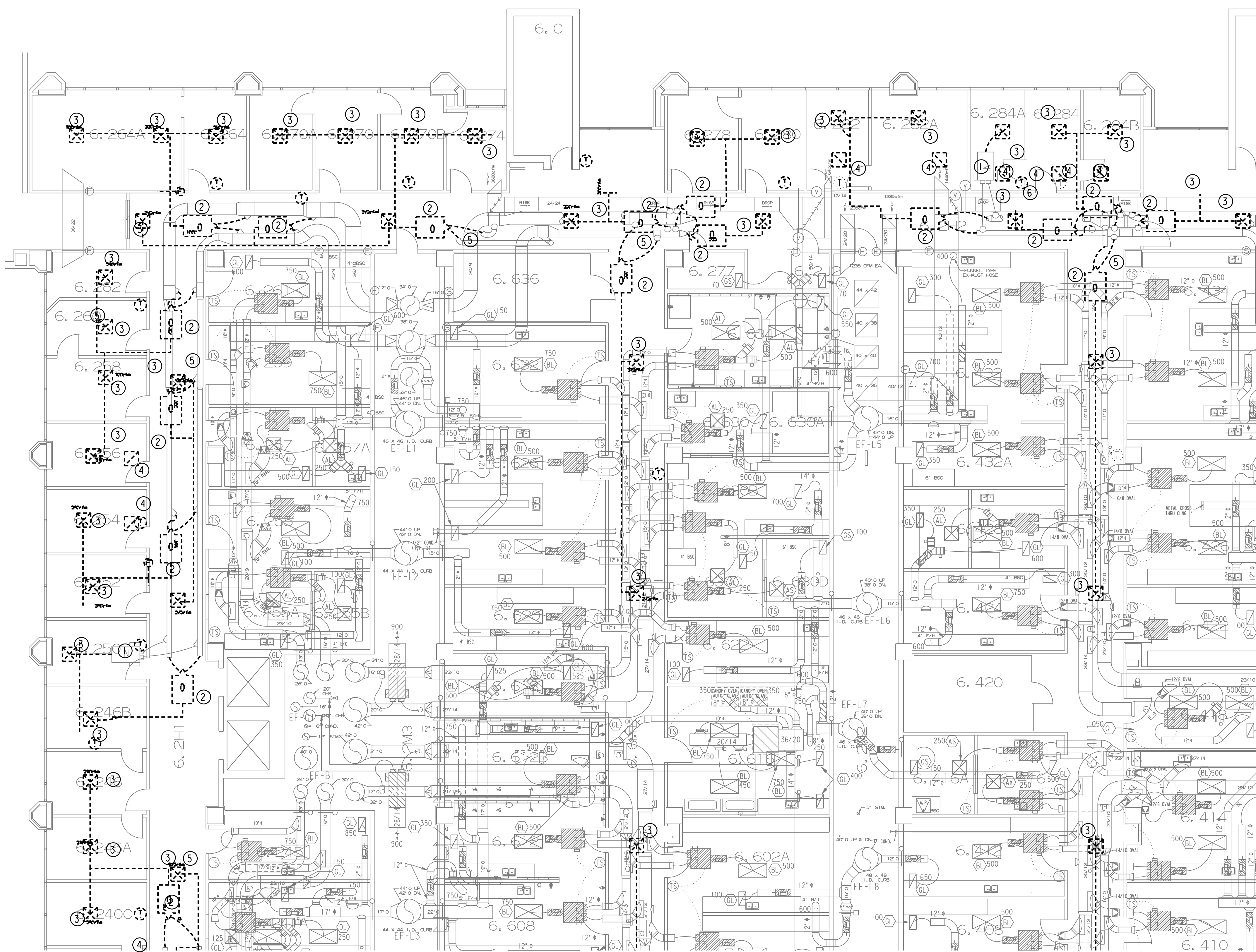

GENERAL NOTES:

- A. THE INTENT OF THE DRAWINGS IS NOT TO RELOCATE SPRINKLER HEADS OR FA DEVICES. IF NEW LIGHT OR DIFFUSER LOCATION DOES NOT WORK WITH EXISTING SPRINKLER/FA DEVICE, PLEASE CONTACT ENGINEER OF RECORD FOR FURTHER DIRECTION.

DRAWING NOTES:

- ① EXISTING DUAL DUCT BOX TO REMAIN. REPLACE CONTROLLER WITH NEW CONTROLLER TO MATCH NEW BOX. REBALANCE TO NEW MIN AS NOTED ON SCHEDULE.
- ② REMOVE DUAL DUCT BOX ABOVE CEILING AND RELATED TEMPERATURE SENSOR, CONTROLS, DOWNSTREAM DUCT AND FLEX.
- ③ REMOVE EXISTING DIFFUSER AND FLEX.
- ④ REMOVE RETURN AIR GRILLE..
- ⑤ FIELD VERIFY SIZE OF TAPS. REUSE IF TAPS IS CORRECT SIZE FOR RENOVATION.
- ⑥ REMOVE ABANDONED PNEUMATIC TEMP. SENSOR AND ASSOCIATED PIPING. PATCH WALL. CAP WITH COMPRESSION FITTING AS CLOSE TO THE TRUNK LINE AS POSSIBLE.

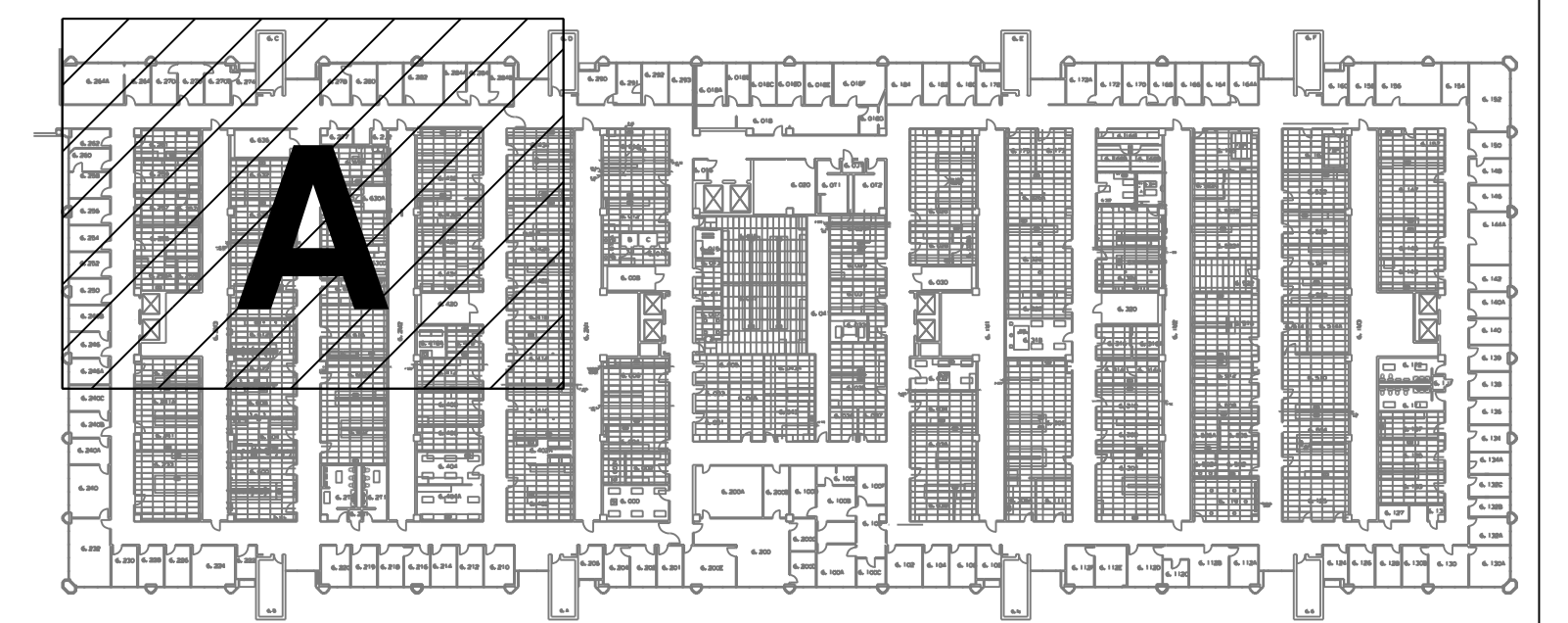

1 MECHANICAL DEMO AREA A PLAN
SCALE: 1/8" = 1'-0"

**UTHSC
MSB OFFICE AIR DISTRIBUTION-6TH FLOOR**

E&C PROJECT # 3300

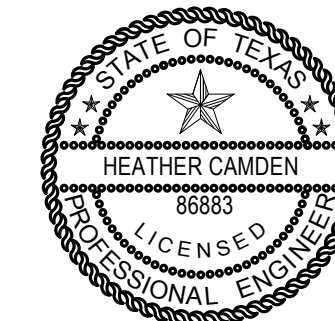

THE SEAL APPEARING ON THIS DRAWING WAS AUTHORIZED BY:
Digitally signed by Heather Camden
Camden
Date: 2017.03.03 11:00:55-06'00'
E&C Engineers & Consultants Inc.
Texas Firm Registration No: F-003068

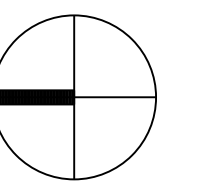

SKETCH: DEMO AREA A

DRAWING: M 1.61

REVISION: CONSTRUCTION

SCALE: 1/8"=1'-0"

DATE: 03-03-2017

E&C
Engineers & Consultants Inc.
TX Firm Registration No: F-003068
1010 Lamar, Suite 650
Houston, Texas 77002
Tel 713/580-8800
Fax 713/580-8888
www.eceng.com

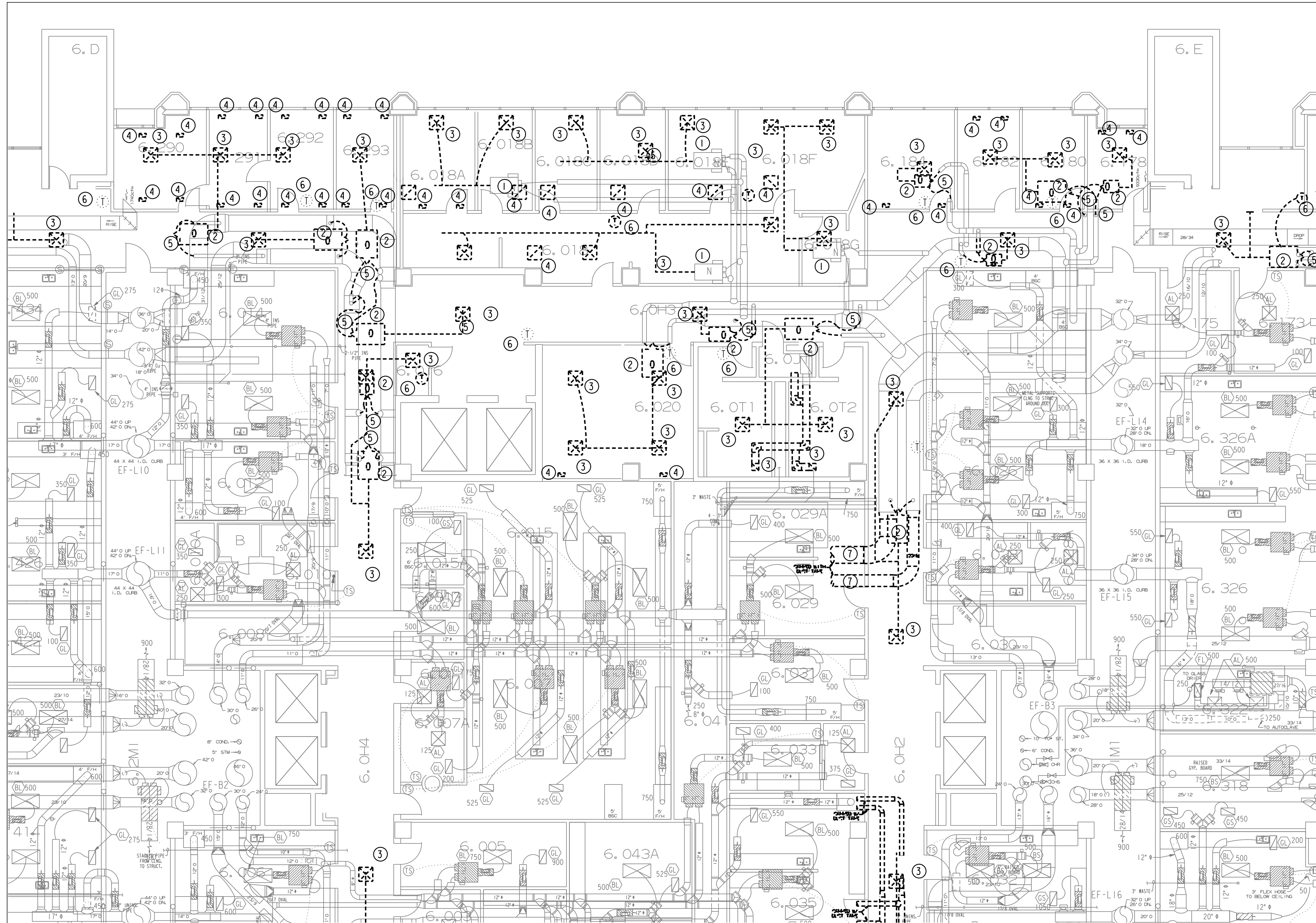

GENERAL NOTES:

A. THE INTENT OF THE DRAWINGS IS NOT TO RELOCATE SPRINKLER HEADS OR FA DEVICES. IF NEW LIGHT OR DIFFUSER LOCATION DOES NOT WORK WITH EXISTING SPRINKLER/FA DEVICE, PLEASE CONTACT ENGINEER OF RECORD FOR FURTHER DIRECTION.

DRAWING NOTES:

- ① EXISTING DUAL DUCT BOX TO REMAIN. REPLACE CONTROLLER WITH NEW CONTROLLER TO MATCH NEW BOX. REBALANCE TO NEW MIN AS NOTED ON SCHEDULE.
- ② REMOVE DUAL DUCT BOX ABOVE CEILING AND RELATED TEMPERATURE SENSOR, CONTROLS, DOWNSTREAM DUCT AND FLEX.
- ③ REMOVE EXISTING DIFFUSER AND FLEX.
- ④ REMOVE RETURN AIR GRILLE..
- ⑤ FIELD VERIFY SIZE OF TAPS. REUSE IF TAPS IS CORRECT SIZE FOR RENOVATION.
- ⑥ REMOVE ABANDONED PNEUMATIC TEMP. SENSOR AND ASSOCIATED PIPING. PATCH WALL. CAP WITH COMPRESSION FITTING AS CLOSE TO THE TRUNK LINE AS POSSIBLE.
- ⑦ REMOVE ABANDONED IN PLACE DUCTWORK AS NOTED. PROVIDE AIRTIGHT SHEETMETAL CAP INCLUDING SHEETMETAL SCREWS, MASTIC AND INSULATION TO MATCH EXISTING.

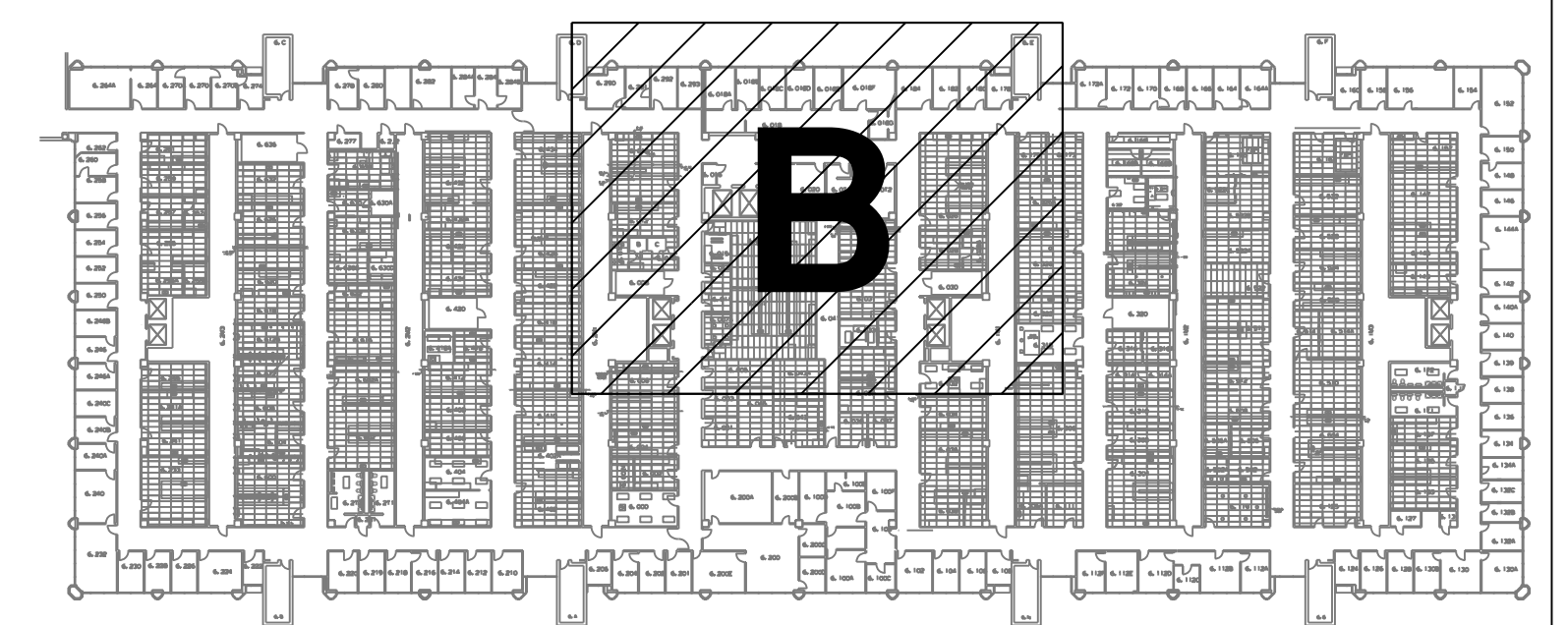

1 MECHANICAL DEMO AREA B PLAN
SCALE: 1/8" = 1'-0"

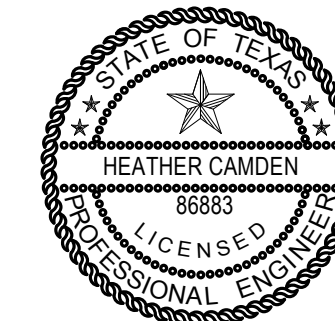

THE SEAL APPEARING ON THIS DRAWING WAS AUTHORIZED BY:
Digitally signed by Heather Camden
Date: 2017.03.03 11:00:55-06'00'
E&C Engineers & Consultants Inc.
Texas Firm Registration No: F-003068

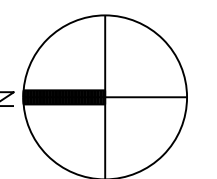

**UTHSC
MSB OFFICE AIR DISTRIBUTION-6TH FLOOR**

E&C PROJECT # 3300

SKETCH: DEMO AREA B
DRAWING: M 1.62
REVISION: CONSTRUCTION
SCALE: 1/8"=1'-0"
DATE: 03-03-2017

E&C
Engineers & Consultants Inc.
TX Firm Registration No: F-003068
1010 Lamar, Suite 650
Houston, Texas 77002
Tel 713/580-8800
Fax 713/580-8888
www.eceng.com

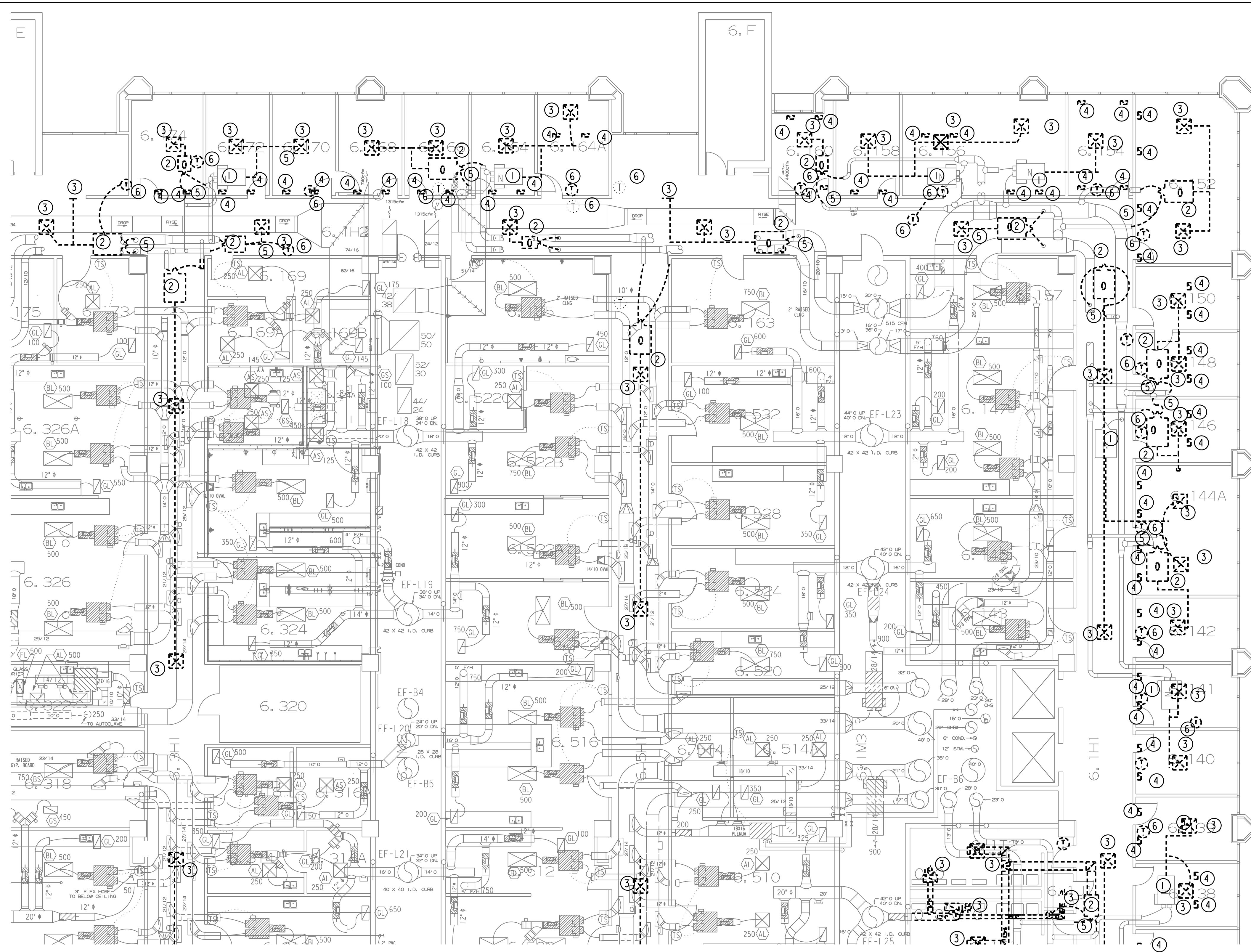

GENERAL NOTES:

- A. THE INTENT OF THE DRAWINGS IS NOT TO RELOCATE SPRINKLER HEADS OR FA DEVICES. IF NEW LIGHT OR DIFFUSER LOCATION DOES NOT WORK WITH EXISTING SPRINKLER/FA DEVICE, PLEASE CONTACT ENGINEER OF RECORD FOR FURTHER DIRECTION.

DRAWING NOTES:

- ① EXISTING DUAL DUCT BOX TO REMAIN. REPLACE CONTROLLER WITH NEW CONTROLLER TO MATCH NEW BOX. REBALANCE TO NEW MIN AS NOTED ON SCHEDULE.
- ② REMOVE DUAL DUCT BOX ABOVE CEILING AND RELATED TEMPERATURE SENSOR, CONTROLS, DOWNSTREAM DUCT AND FLEX.
- ③ REMOVE EXISTING DIFFUSER AND FLEX.
- ④ REMOVE RETURN AIR GRILLE.
- ⑤ FIELD VERIFY SIZE OF TAPS. REUSE IF TAPS IS CORRECT SIZE FOR RENOVATION.
- ⑥ REMOVE ABANDONED PNEUMATIC TEMP. SENSOR AND ASSOCIATED PIPING, PATCH WALL, CAP WITH COMPRESSION FITTING AS CLOSE TO THE TRUNK LINE AS POSSIBLE.

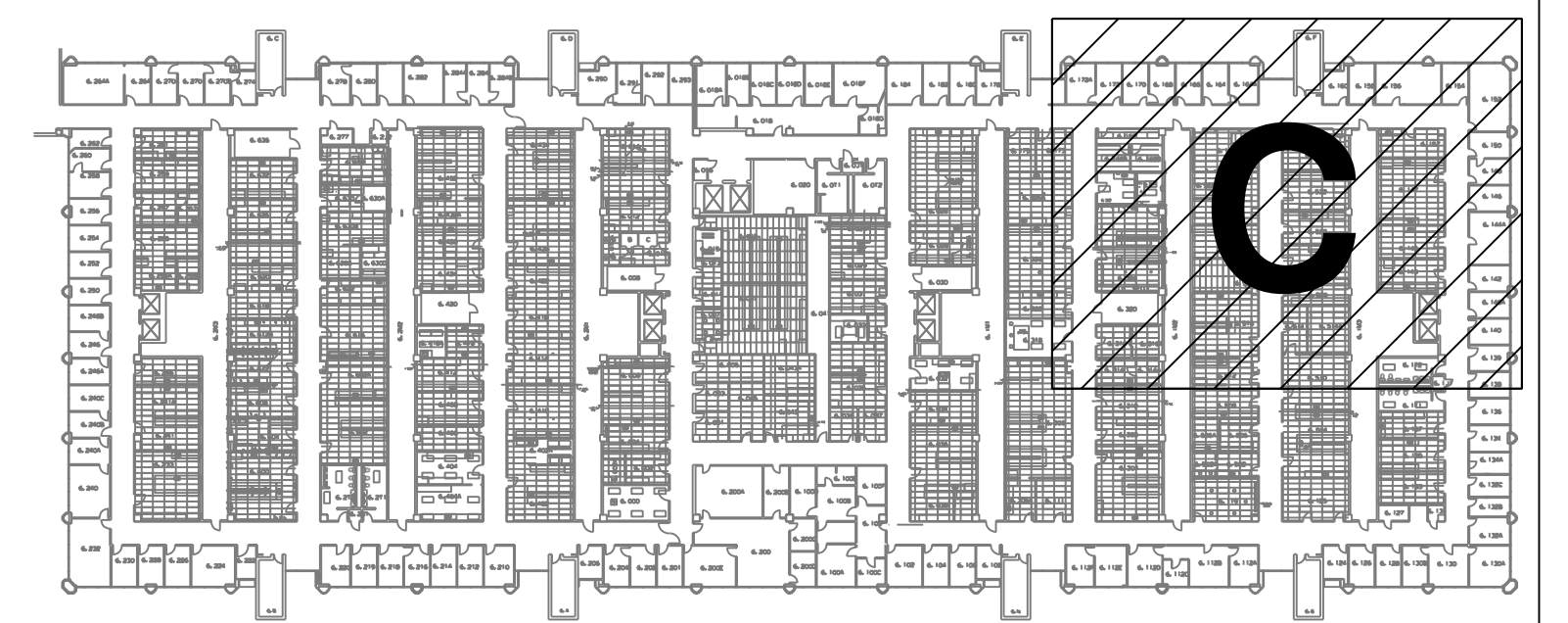

1 MECHANICAL DEMO AREA C PLAN
SCALE: 1/8" = 1'-0"

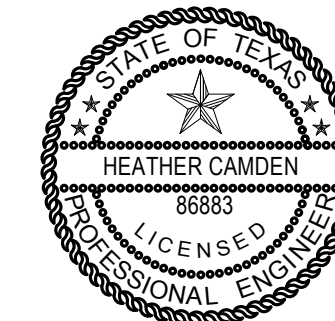

THE SEAL APPEARING ON THIS DRAWING WAS AUTHORIZED BY:
Digitally signed by Heather Camden
Camden
Date: 2017.03.03 11:00:55-06'00'
E&C Engineers & Consultants Inc.
Texas Firm Registration No: F-003068

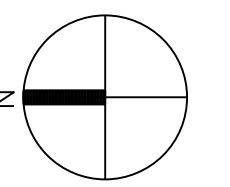

**UTHSC
MSB OFFICE AIR DISTRIBUTION-6TH FLOOR**

E&C PROJECT # 3300

E&C
Engineers & Consultants Inc.
TX Firm Registration No: F-003068
1010 Lamar, Suite 650
Houston, Texas 77002
Tel 713/580-8800
Fax 713/580-8888
www.eceng.com

SKETCH: DEMO AREA C
DRAWING: M 1.63
REVISION: CONSTRUCTION
SCALE: 1/8"=1'-0"
DATE: 03-03-2017

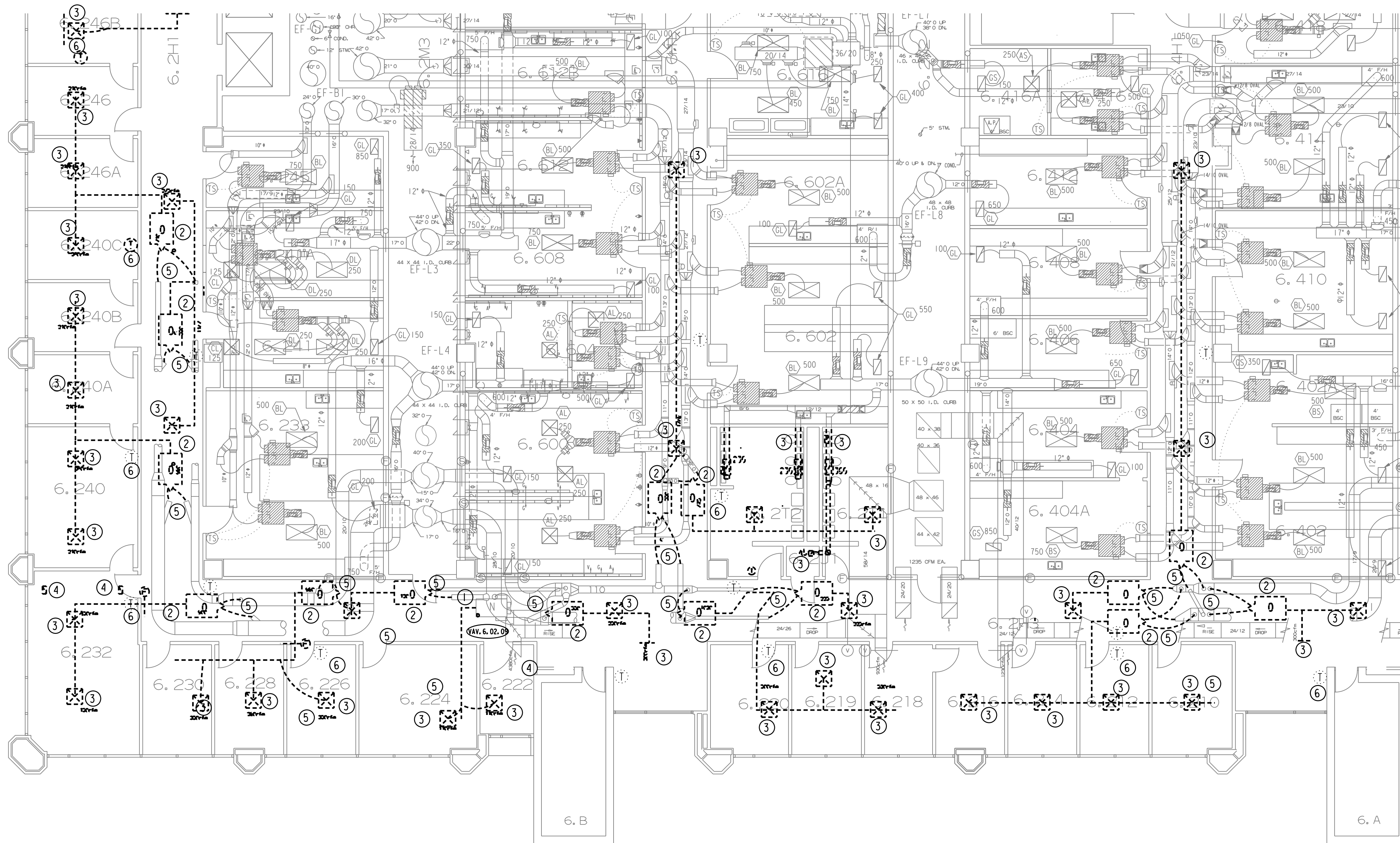

GENERAL NOTES:

A. THE INTENT OF THE DRAWINGS IS NOT TO RELOCATE SPRINKLER HEADS OR FA DEVICES. IF NEW LIGHT OR DIFFUSER LOCATION DOES NOT WORK WITH EXISTING SPRINKLER/FA DEVICE, PLEASE CONTACT ENGINEER OF RECORD FOR FURTHER DIRECTION.

DRAWING NOTES:

- ① EXISTING DUAL DUCT BOX TO REMAIN. REPLACE CONTROLLER WITH NEW CONTROLLER TO MATCH NEW BOX. REBALANCE TO NEW MIN AS NOTED ON SCHEDULE.
- ② REMOVE DUAL DUCT BOX ABOVE CEILING AND RELATED TEMPERATURE SENSOR, CONTROLS, DOWNSTREAM DUCT AND FLEX.
- ③ REMOVE EXISTING DIFFUSER AND FLEX.
- ④ REMOVE RETURN AIR GRILLE..
- ⑤ FIELD VERIFY SIZE OF TAPS. REUSE IF TAPS IS CORRECT SIZE FOR RENOVATION.
- ⑥ REMOVE ABANDONED PNEUMATIC TEMP. SENSOR AND ASSOCIATED PIPING. PATCH WALL. CAP WITH COMPRESSION FITTING AS CLOSE TO THE TRUNK LINE AS POSSIBLE.

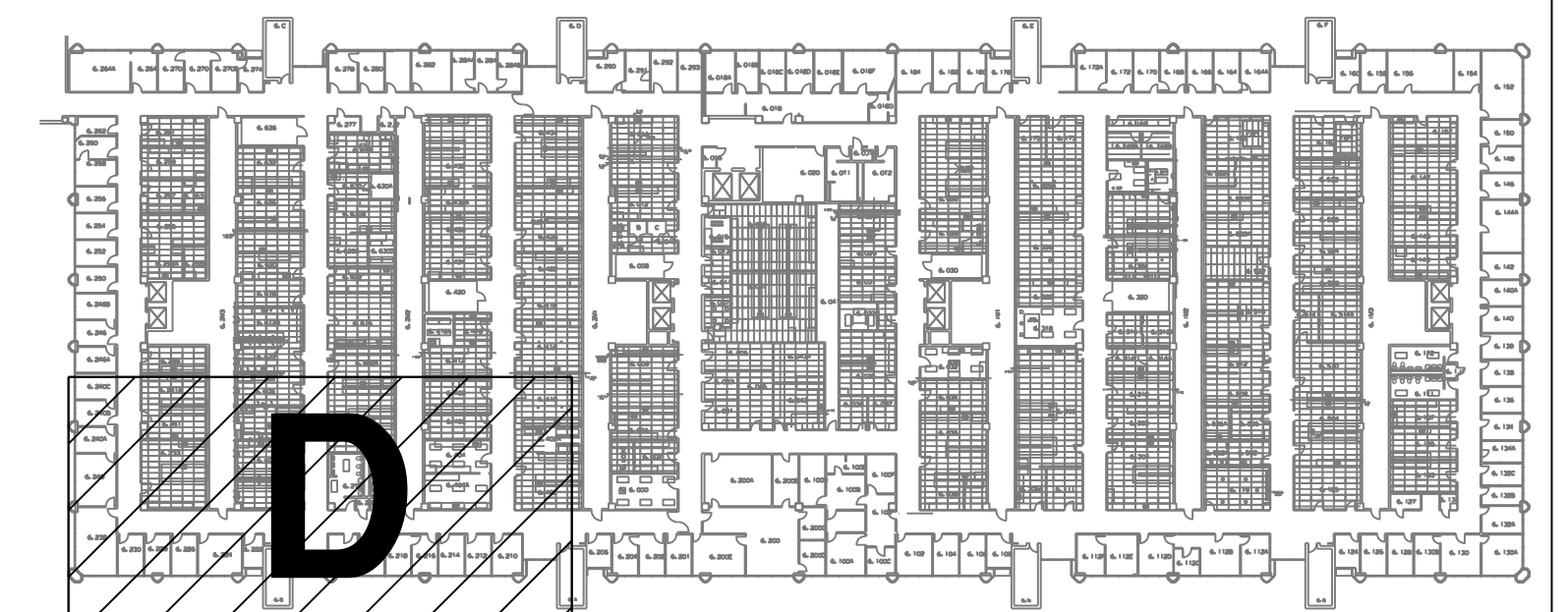

1 MECHANICAL DEMO AREA D PLAN
SCALE: 1/8" = 1' - 0"

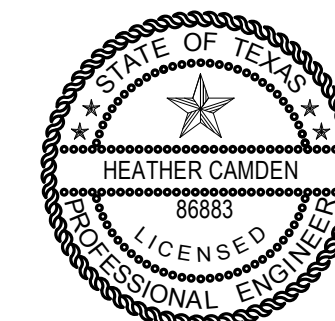

THE SEAL APPEARING ON THIS DRAWING WAS AUTHORIZED BY:
Digitally signed by Heather Camden
Date: 2017.03.03 11:00:55-06'00'
E&C Engineers & Consultants Inc.
Texas Firm Registration No: F-003068

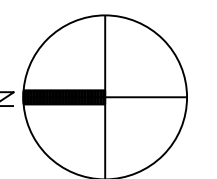

**UTHSC
MSB OFFICE AIR DISTRIBUTION-6TH FLOOR**

E&C PROJECT # 3300

E&C
Engineers & Consultants Inc.
TX Firm Registration No: F-003068
1010 Lamar, Suite 650
Houston, Texas 77002
Tel 713/580-8800
Fax 713/580-8888
www.eceng.com

SKETCH: DEMO AREA D
DRAWING: M 1.64
REVISION: CONSTRUCTION
SCALE: 1/8"=1'-0"
DATE: 03-03-2017

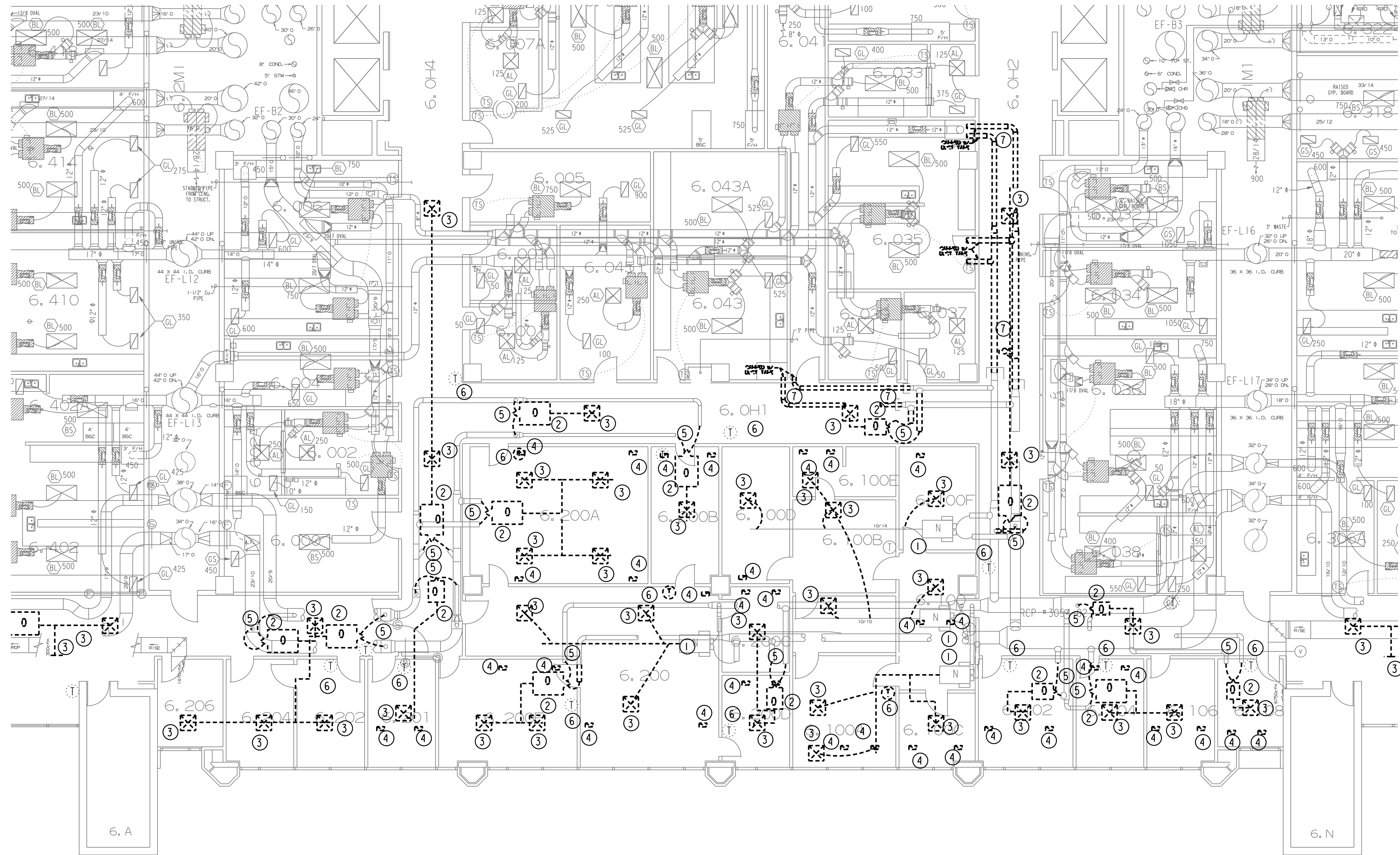

GENERAL NOTES:

- A. THE INTENT OF THE DRAWINGS IS NOT TO RELOCATE SPRINKLER HEADS OR FA DEVICES. IF NEW LIGHT OR DIFFUSER LOCATION DOES NOT WORK WITH EXISTING SPRINKLER/FA DEVICE, PLEASE CONTACT ENGINEER OF RECORD FOR FURTHER DIRECTION.

DRAWING NOTES:

- ① EXISTING DUAL DUCT BOX TO REMAIN. REPLACE CONTROLLER WITH NEW CONTROLLER TO MATCH NEW BOX. REBALANCE TO NEW MIN AS NOTED ON SCHEDULE.
- ② REMOVE DUAL DUCT BOX ABOVE CEILING AND RELATED TEMPERATURE SENSOR, CONTROLS, DOWNSTREAM DUCT AND FLEX.
- ③ REMOVE EXISTING DIFFUSER AND FLEX.
- ④ REMOVE RETURN AIR GRILLE..
- ⑤ FIELD VERIFY SIZE OF TAPS. REUSE IF TAPS IS CORRECT SIZE FOR RENOVATION.
- ⑥ REMOVE ABANDONED PNEUMATIC TEMP. SENSOR AND ASSOCIATED PIPING. PATCH WALL. CAP WITH COMPRESSION FITTING AS CLOSE TO THE TRUNK LINE AS POSSIBLE.
- ⑦ REMOVE ABANDONED IN PLACE DUCTWORK AS NOTED. PROVIDE AIRTIGHT SHEETMETAL CAP INCLUDING SHEETMETAL SCREWS, MASTIC AND INSULATION TO MATCH EXISTING.

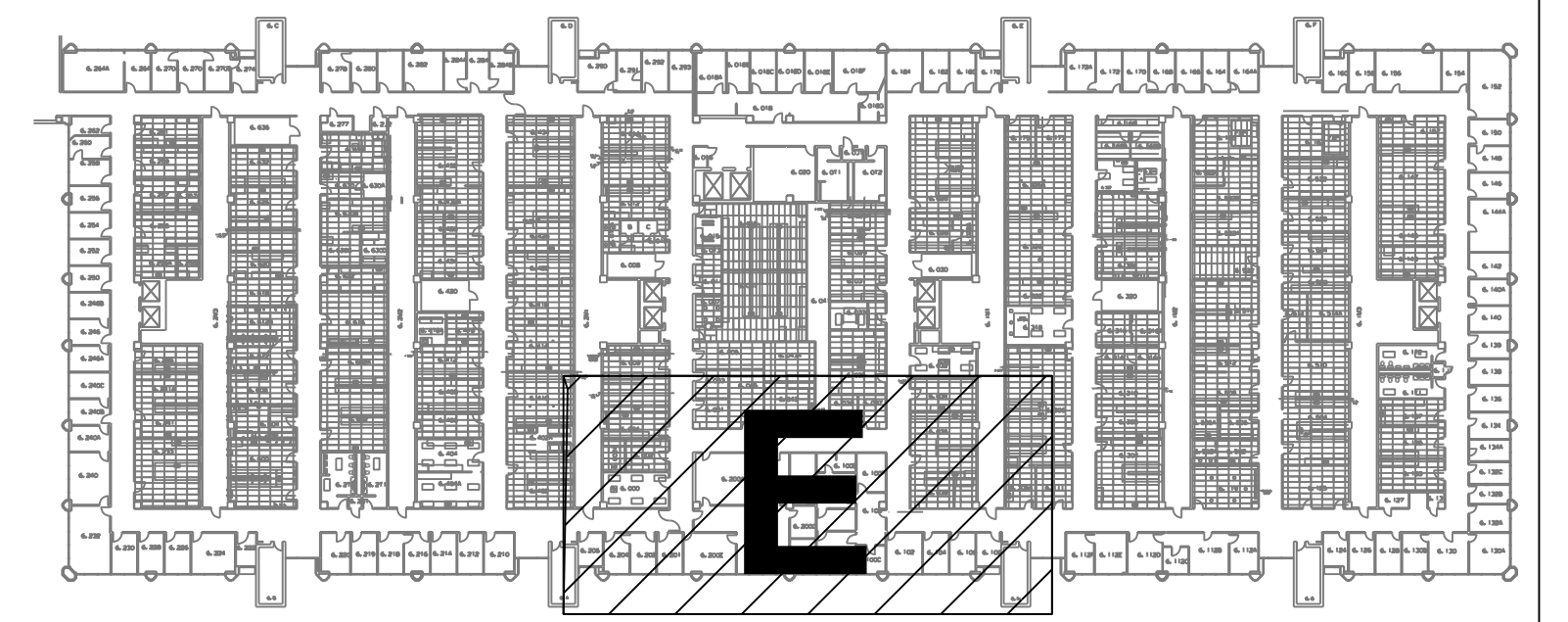

1 MECHANICAL DEMO AREA E PLAN
SCALE: 1/8" = 1' - 0"

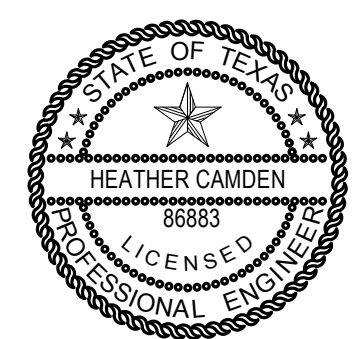

THE SEAL APPEARING ON THIS DRAWING WAS AUTHORIZED BY:
Digitally signed by Heather Camden
Date: 2017.03.03 11:00:55-06'00'
E&C Engineers & Consultants Inc.
Texas Firm Registration No: F-003068

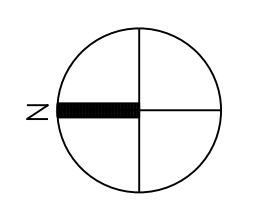

E&C
Engineers & Consultants Inc.
TX Firm Registration No: F-003068
1010 Lamar, Suite 650
Houston, Texas 77002
Tel 713/580-8800
Fax 713/580-8888
www.eceng.com

**UTHSC
MSB OFFICE AIR DISTRIBUTION-6TH FLOOR**

E&C PROJECT # 3300

SKETCH: DEMO AREA E
DRAWING: M 1.65
REVISION: CONSTRUCTION
SCALE: 1/8"=1'-0"
DATE: 03-03-2017

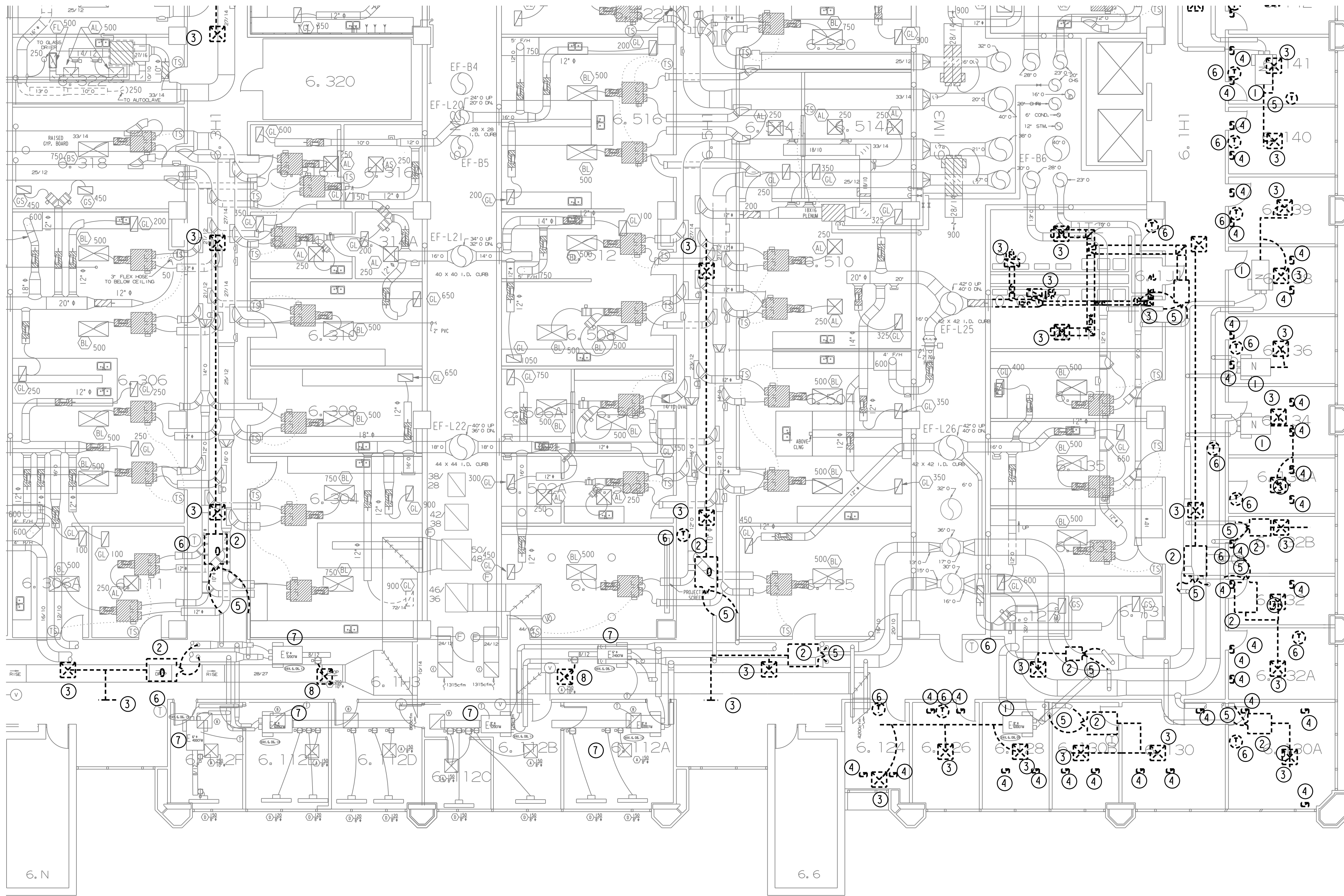

GENERAL NOTES:

- A. THE INTENT OF THE DRAWINGS IS NOT TO RELOCATE SPRINKLER HEADS OR FA DEVICES. IF NEW LIGHT OR DIFFUSER LOCATION DOES NOT WORK WITH EXISTING SPRINKLER/FA DEVICE, PLEASE CONTACT ENGINEER OF RECORD FOR FURTHER DIRECTION.

DRAWING NOTES:

- ① EXISTING DUAL DUCT BOX TO REMAIN. REPLACE CONTROLLER WITH NEW CONTROLLER TO MATCH NEW BOX. REBALANCE TO NEW MIN AS NOTED ON SCHEDULE.
- ② REMOVE DUAL DUCT BOX ABOVE CEILING AND RELATED TEMPERATURE SENSOR, CONTROLS, DOWNSTREAM DUCT AND FLEX.
- ③ REMOVE EXISTING DIFFUSER AND FLEX.
- ④ REMOVE RETURN AIR GRILLE..
- ⑤ FIELD VERIFY SIZE OF TAPS. REUSE IF TAPS IS CORRECT SIZE FOR RENOVATION.
- ⑥ REMOVE ABANDONED PNEUMATIC TEMP. SENSOR AND ASSOCIATED PIPING. PATCH WALL. CAP WITH COMPRESSION FITTING AS CLOSE TO THE TRUNK LINE AS POSSIBLE.
- ⑦ NEW BOXES FROM NEW CONSTRUCTION. NO DEMO.
- ⑧ RELOCATE SUPPLY AIR DIFFUSER IN THE HALLWAY AS NOTED ON M2.66.

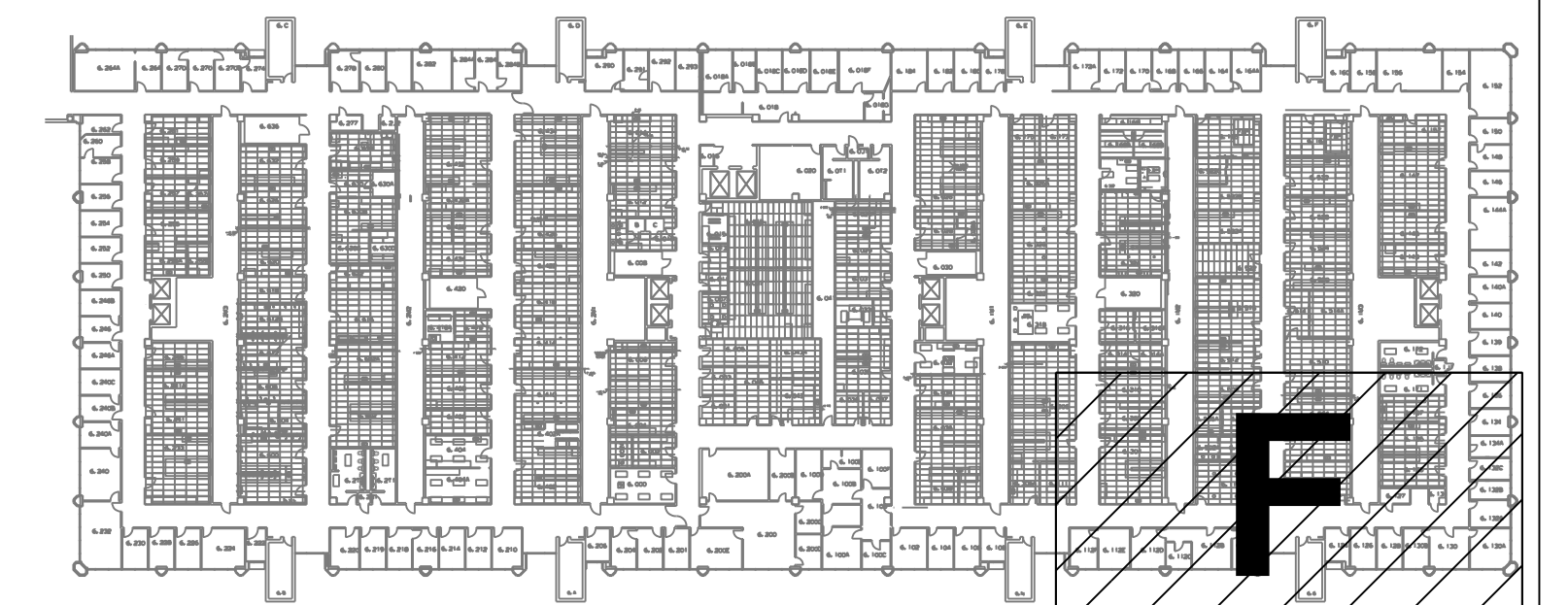

1 MECHANICAL DEMO AREA F PLAN
SCALE: 1/8" = 1'-0"

**UTHSC
MSB OFFICE AIR DISTRIBUTION-6TH FLOOR**

E&C PROJECT # 3300

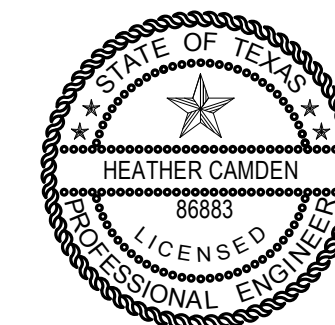

THE SEAL APPEARING ON THIS DRAWING WAS AUTHORIZED BY:
Digitally signed by Heather Camden
Date: 2017.03.03 11:00:55-06'00'
E&C Engineers & Consultants Inc.
Texas Firm Registration No: F-003068

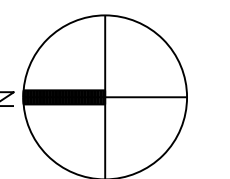

E&C
Engineers & Consultants Inc.
TX Firm Registration No: F-003068
1010 Lamar, Suite 650
Houston, Texas 77002
Tel 713/580-8800
Fax 713/580-8888
www.eceng.com

SKETCH: DEMO AREA F
DRAWING: M 1.66
REVISION: CONSTRUCTION
SCALE: 1/8"=1'-0"
DATE: 03-03-2017

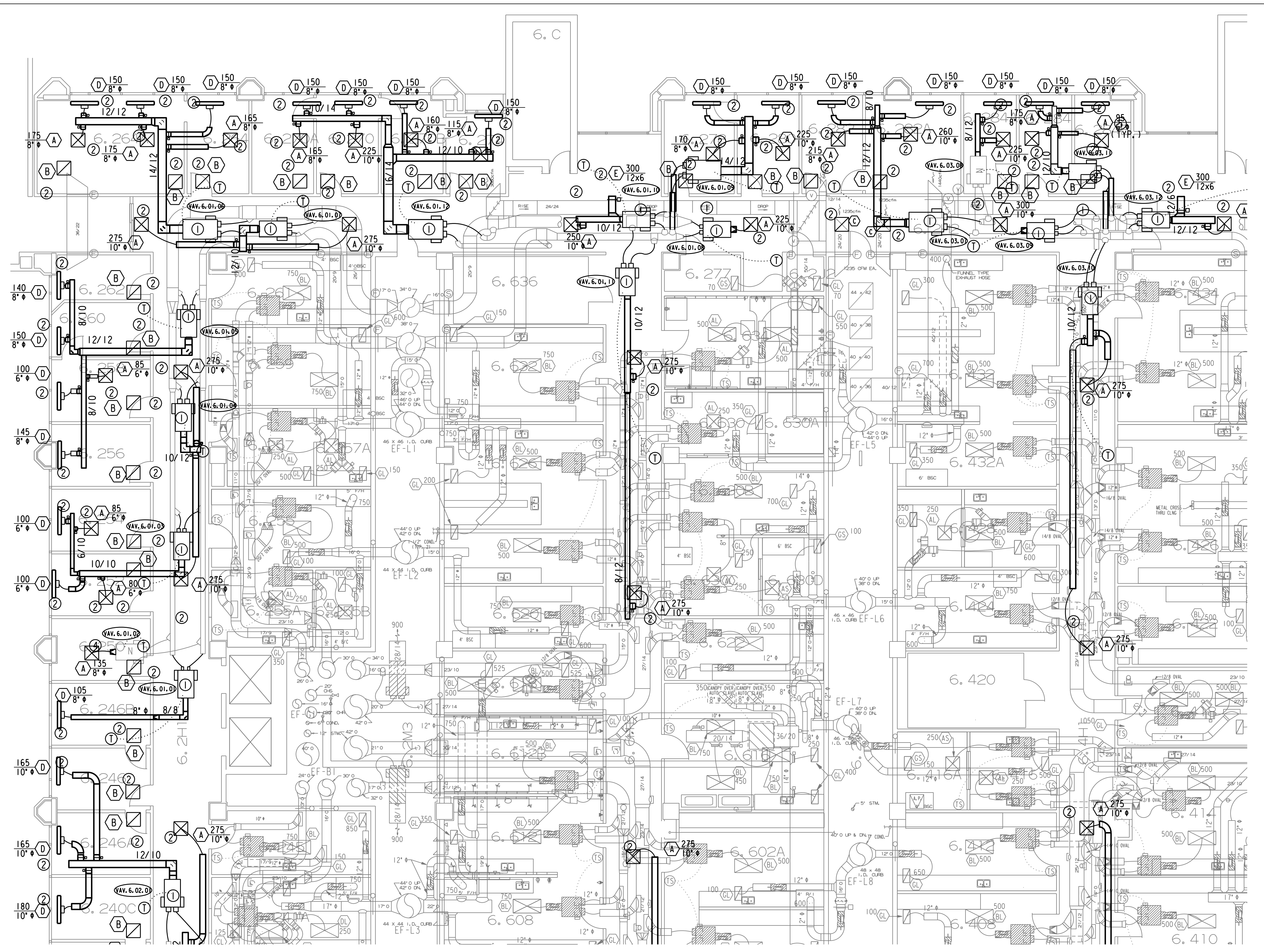

GENERAL NOTES:

- A. THE INTENT OF THE DRAWINGS IS NOT TO RELOCATE SPRINKLER HEADS OR FA DEVICES. IF NEW LIGHT OR DIFFUSER LOCATION DOES NOT WORK WITH EXISTING SPRINKLER/FA DEVICE, PLEASE CONTACT ENGINEER FOR FURTHER DIRECTION.
- B. PROVIDE ALTERNATE PRICING (ALTERNATE NUMBER 1) TO PROVIDE MOTION SENSORS. IN EVERY OFFICE, MOTION SENSORS SHALL BE TO TIE INTO THE BAS TO CONTROL OCCUPIED /UNOCCUPIED MODE.

DRAWING NOTES:

- ① INSTALL NEW DUAL DUCT BOX WITH CONTROLS, DUCT, FLEX, AND DIFFUSERS AS SHOWN AND SPECIFIED.
- ② PROVIDE NEW FLEX AND DIFFUSER AS NOTED.
- ③ TAP EXISTING DUCT FOR NEW DIFFUSER.
- ④ VERIFY EXISTING DUCT SIZE AND NOTE ON AS-BUILTS.
- ⑤ IF ALTERNATE 1 IS TAKEN, REFER TO DRAWING PLAN AS NEEDED FOR DIFFUSER LOCATIONS.

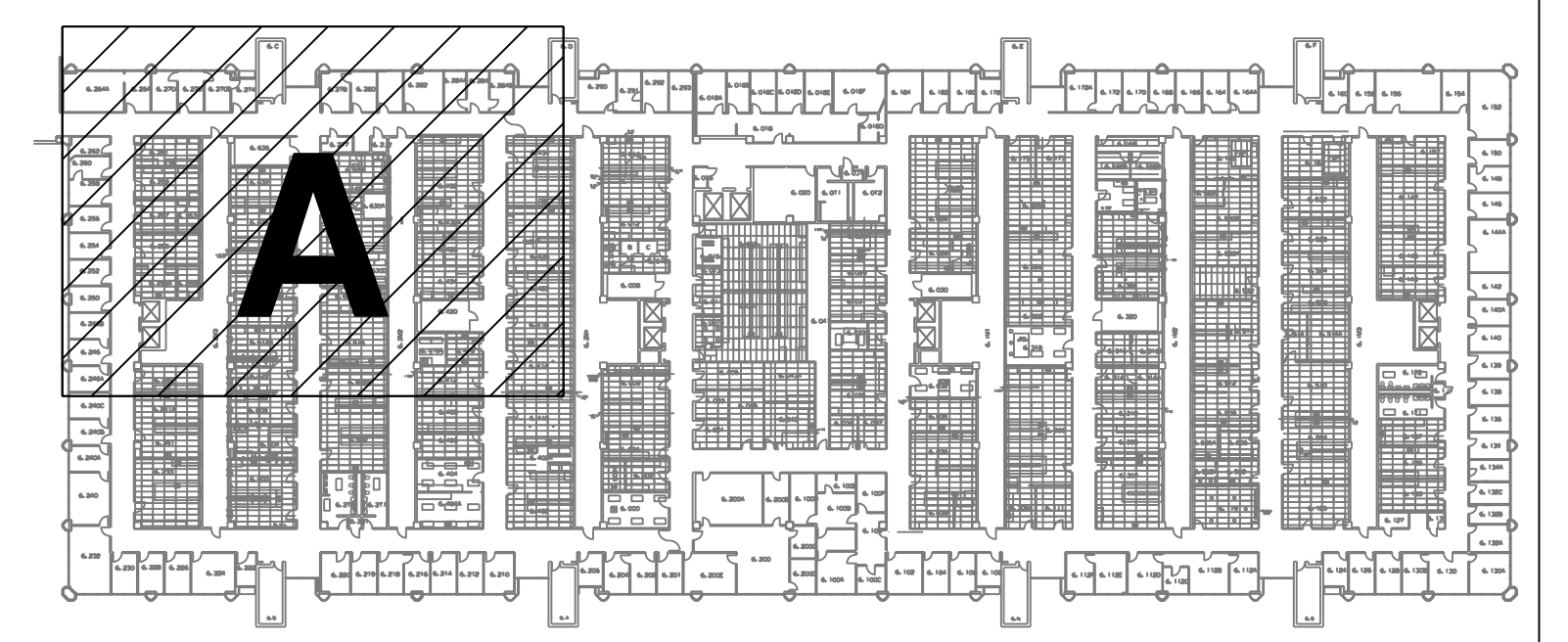

1 MECHANICAL RENO AREA A PLAN
SCALE: 1/8" = 1'-0"



THE SEAL APPEARING ON THIS DRAWING WAS AUTHORIZED BY:
Digitally signed by Heather Camden
Date: 2017.03.03 11:00:55-06'00'
E&C Engineers & Consultants Inc.
Texas Firm Registration No: F-003068

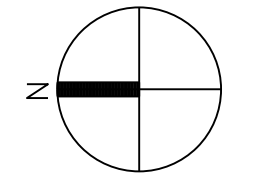

E&C
Engineers & Consultants Inc.
TX Firm Registration No: F-003068
1010 Lamar, Suite 650
Houston, Texas 77002
Tel 713/580-8800
Fax 713/580-8888
www.eceng.com

**UTHSC
MSB OFFICE AIR DISTRIBUTION-6TH FLOOR**

E&C PROJECT # 3300

SKETCH: RENO AREA A
DRAWING: M 2.61
REVISION: CONSTRUCTION
SCALE: 1/8"=1'-0"
DATE: 03-03-2017

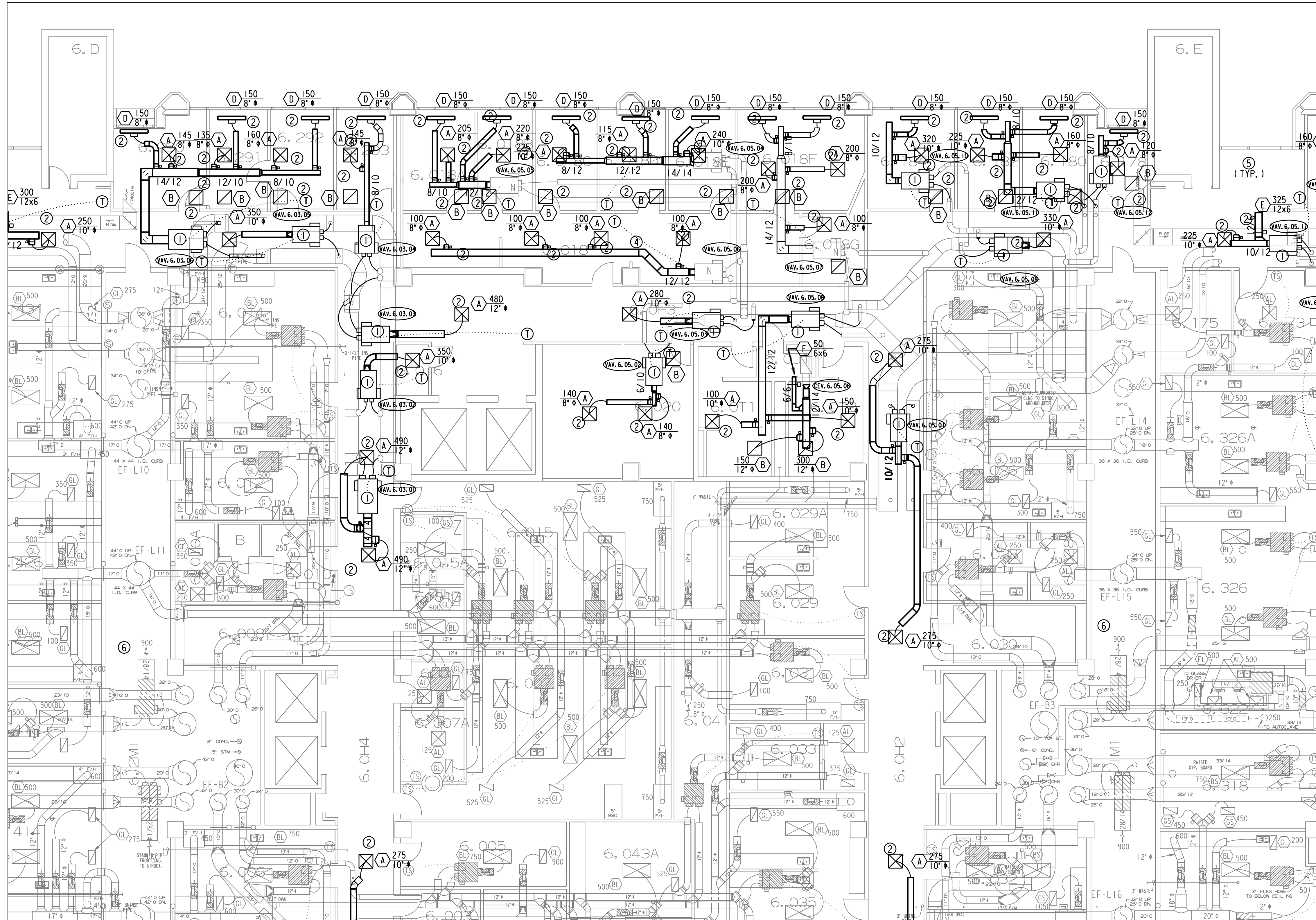

GENERAL NOTES:

- A. THE INTENT OF THE DRAWINGS IS NOT TO RELOCATE SPRINKLER HEADS OR FA DEVICES. IF NEW LIGHT OR DIFFUSER LOCATION DOES NOT WORK WITH EXISTING SPRINKLER/FA DEVICE, PLEASE CONTACT ENGINEER OF RECORD FOR FURTHER DIRECTION.
- B. PROVIDE ALTERNATE PRICING (ALTERNATE NUMBER 1) TO PROVIDE MOTION SENSORS. IN EVERY OFFICE. MOTION SENSORS SHALL BE TO TIE INTO THE BAS TO CONTROL OCCUPIED /UNOCCUPIED MODE.

DRAWING NOTES:

- ① INSTALL NEW DUAL DUCT BOX WITH CONTROLS, DUCT, FLEX, AND DIFFUSERS AS SHOWN AND SPECIFIED.
- ② PROVIDE NEW FLEX AND DIFFUSER AS NOTED.
- ③ TAP EXISTING DUCT FOR NEW DIFFUSER.
- ④ VERIFY EXISTING DUCT SIZE AND NOTE ON AS-BUILTS.
- ⑤ IF ALTERNATE 1 IS TAKEN, REFER TO DRAWING PLAN AS NEEDED FOR DIFFUSER LOCATIONS.
- ⑥ ADD A NEW NETWORK AUTOMATION ENGINE (NAE) IN THE YELLOW CHASE AND THE GREEN CHASE.

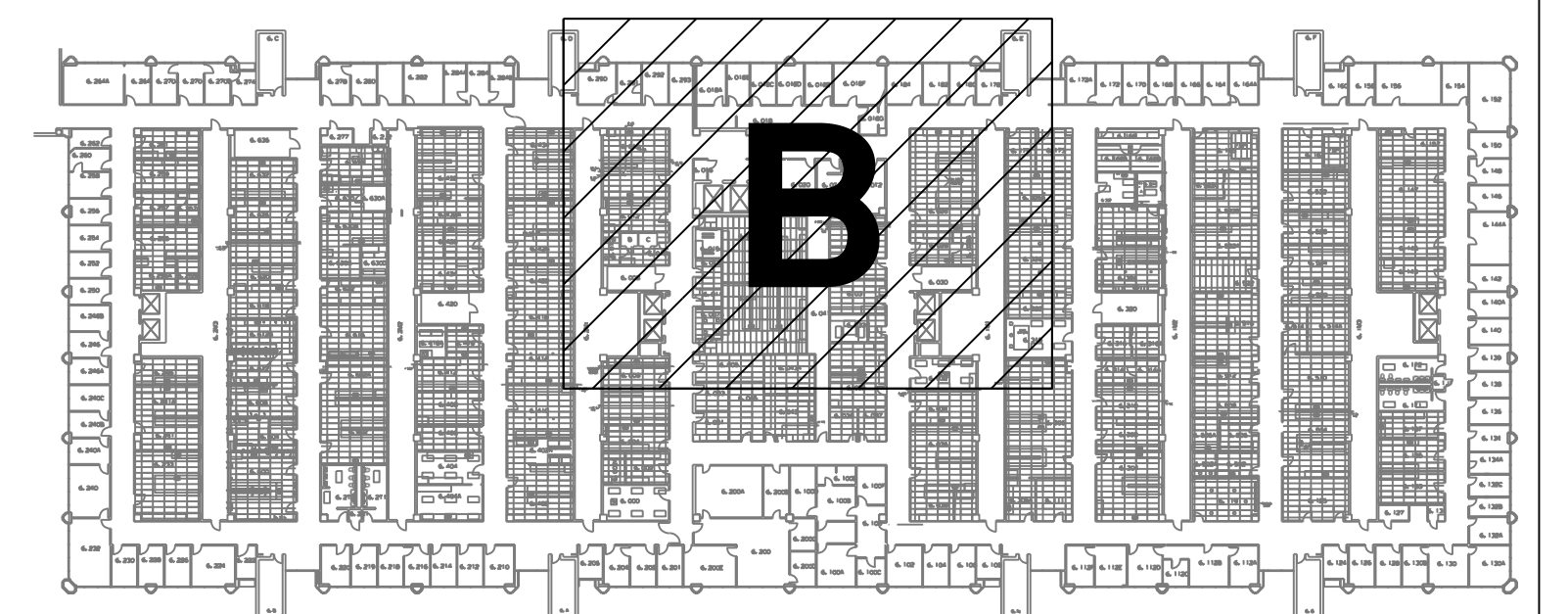

1 MECHANICAL RENO AREA B PLAN
SCALE: 1/8" = 1'-0"

UTHSC
MSB OFFICE AIR DISTRIBUTION-6TH FLOOR

E&C PROJECT # 3300

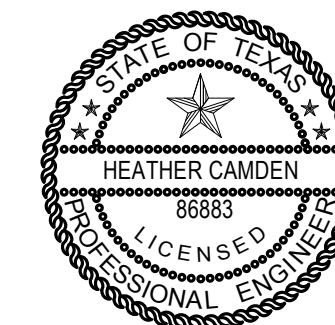

THE SEAL APPEARING ON THIS DRAWING WAS AUTHORIZED BY:
Digitally signed by Heather Camden
Date: 2017.03.03 11:00:55-06'00'
E&C Engineers & Consultants Inc.
Texas Firm Registration No: F-003068

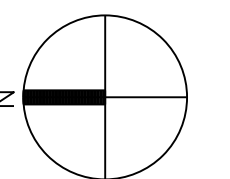

E&C
Engineers & Consultants Inc.
TX Firm Registration No: F-003068
1010 Lamar, Suite 650
Houston, Texas 77002
Tel 713/580-8800
Fax 713/580-8888
www.eceng.com

SKETCH: RENO AREA B
DRAWING: M 2.62
REVISION: CONSTRUCTION
SCALE: 1/8"=1'-0"
DATE: 03-03-2017

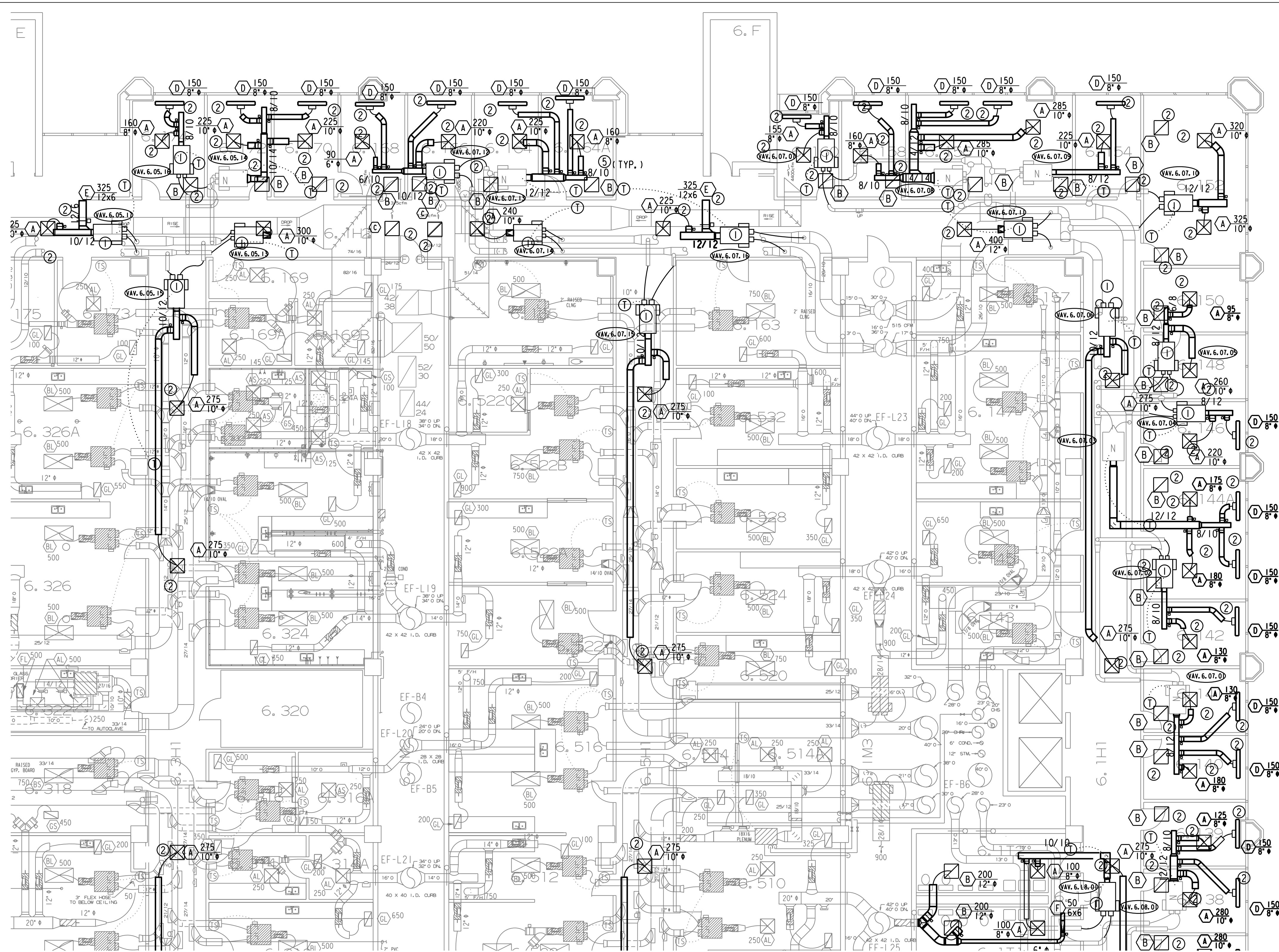

- GENERAL NOTES:
- A. THE INTENT OF THE DRAWINGS IS NOT TO RELOCATE SPRINKLER HEADS OR FA DEVICES. IF NEW LIGHT OR DIFFUSER LOCATION DOES NOT WORK WITH EXISTING SPRINKLER/FA DEVICE, PLEASE CONTACT ENGINEER OF RECORD FOR FURTHER DIRECTION.
 - B. PROVIDE ALTERNATE PRICING (ALTERNATE NUMBER 1) TO PROVIDE MOTION SENSORS. IN EVERY OFFICE. MOTION SENSORS SHALL BE TO TIE INTO THE BAS TO CONTROL OCCUPIED /UNOCCUPIED MODE.

- DRAWING NOTES:
- ① INSTALL NEW DUAL DUCT BOX WITH CONTROLS, DUCT, FLEX, AND DIFFUSERS AS SHOWN AND SPECIFIED.
 - ② PROVIDE NEW FLEX AND DIFFUSER AS NOTED.
 - ③ TAP EXISTING DUCT FOR NEW DIFFUSER.
 - ④ VERIFY EXISTING DUCT SIZE AND NOTE ON AS-BUILTS.
 - ⑤ IF ALTERNATE 1 IS TAKEN, REFER TO DRAWING PLAN AS NEEDED FOR DIFFUSER LOCATIONS.

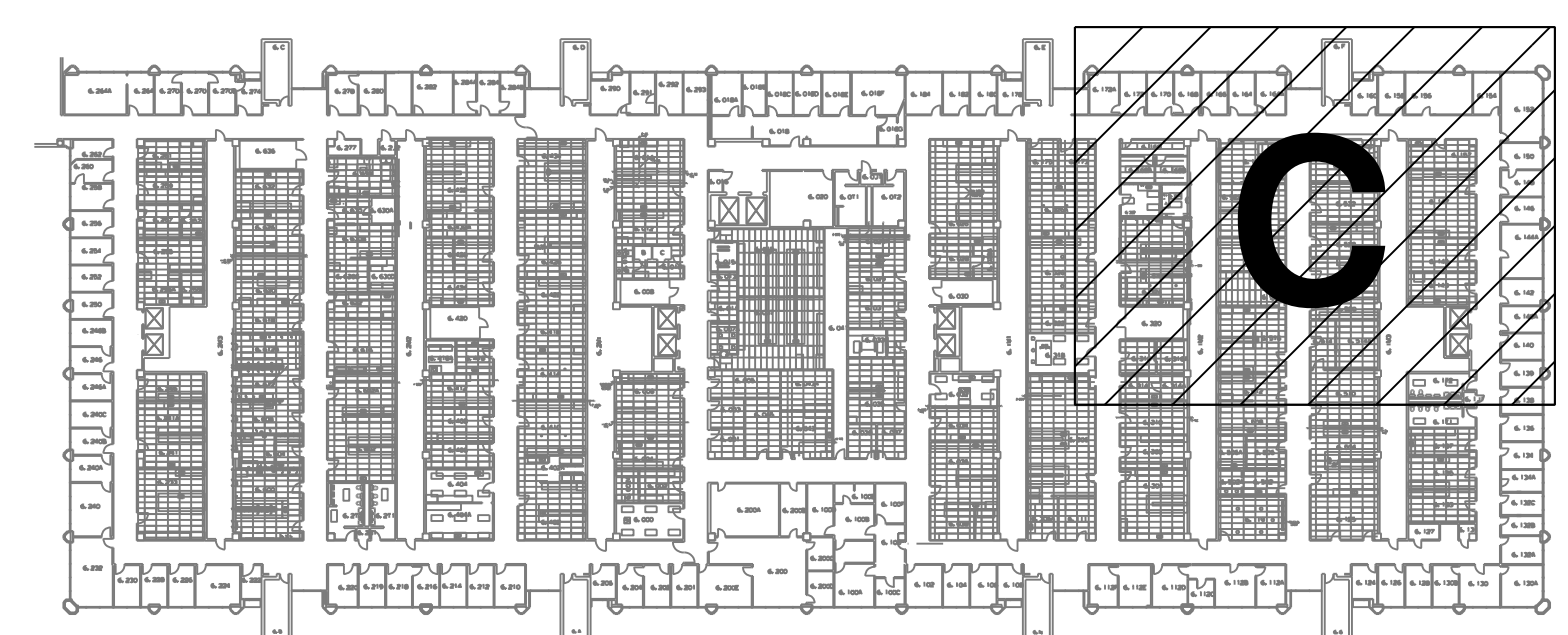

1 MECHANICAL RENO AREA C PLAN
SCALE: 1/8" = 1'-0"

**UTHSC
MSB OFFICE AIR DISTRIBUTION-6TH FLOOR**

E&C
Engineers & Consultants Inc.
TX Firm Registration No: F-003068
1010 Lamar, Suite 650
Houston, Texas 77002
Tel 713/580-8800
Fax 713/580-8888
www.eceng.com

E&C PROJECT # 3300

SKETCH: RENO AREA C
DRAWING: M 2.63
REVISION: CONSTRUCTION
SCALE: 1/8"=1'-0"
DATE: 03-03-2017

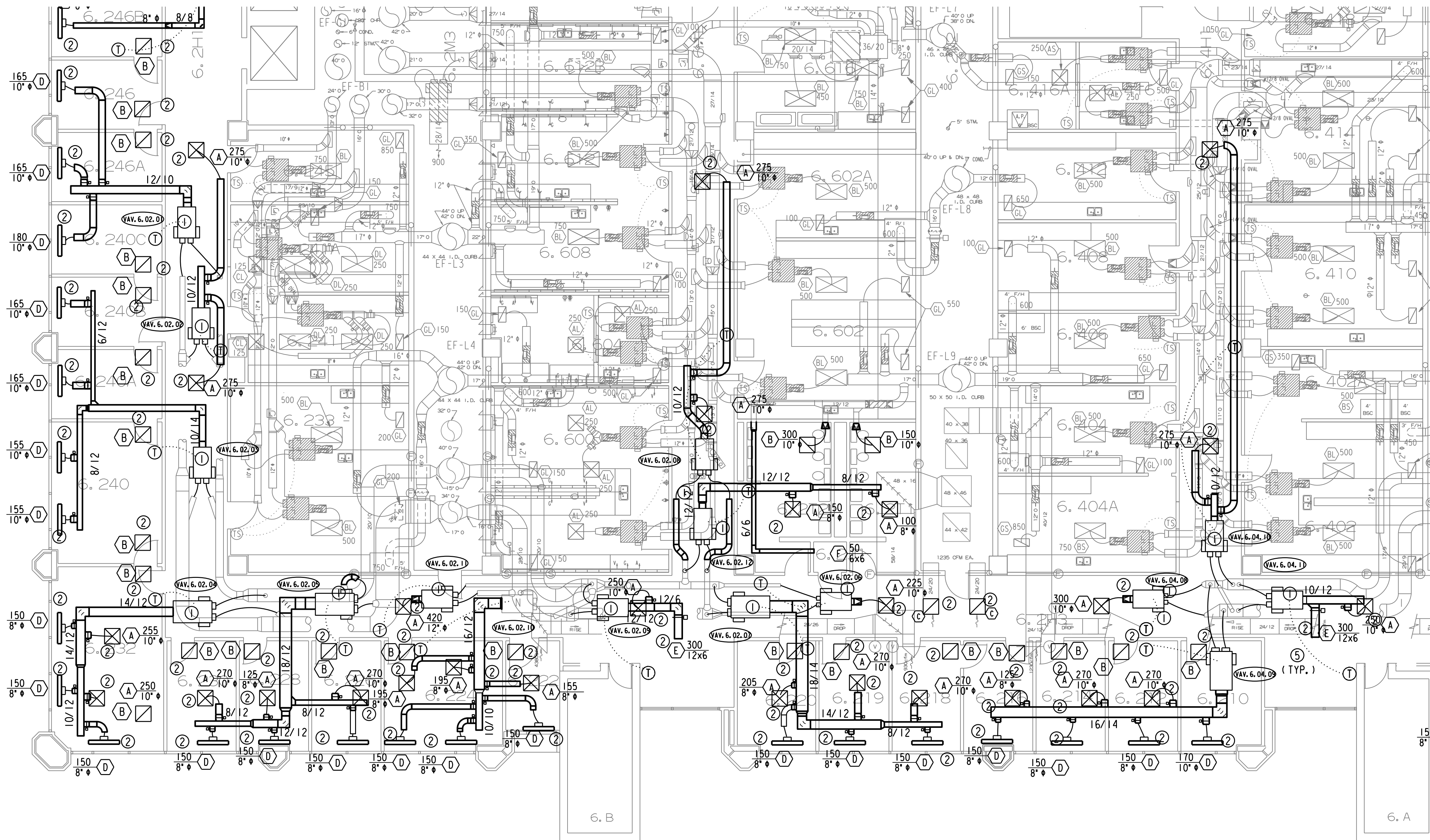

GENERAL NOTES:

- A. THE INTENT OF THE DRAWINGS IS NOT TO RELOCATE SPRINKLER HEADS OR FA DEVICES. IF NEW LIGHT OR DIFFUSER LOCATION DOES NOT WORK WITH EXISTING SPRINKLER/FA DEVICE, PLEASE CONTACT ENGINEER OF RECORD FOR FURTHER DIRECTION.
- B. PROVIDE ALTERNATE PRICING (ALTERNATE NUMBER 1) TO PROVIDE MOTION SENSORS. IN EVERY OFFICE. MOTION SENSORS SHALL BE TO TIE INTO THE BAS TO CONTROL OCCUPIED /UNOCCUPIED MODE.

DRAWING NOTES:

- ① INSTALL NEW DUAL DUCT BOX WITH CONTROLS, DUCT, FLEX, AND DIFFUSERS AS SHOWN AND SPECIFIED.
- ② PROVIDE NEW FLEX AND DIFFUSER AS NOTED.
- ③ TAP EXISTING DUCT FOR NEW DIFFUSER.
- ④ VERIFY EXISTING DUCT SIZE AND NOTE ON AS-BUILTS.
- ⑤ IF ALTERNATE 1 IS TAKEN, REFER TO DRAWING PLAN AS NEEDED FOR DIFFUSER LOCATIONS.

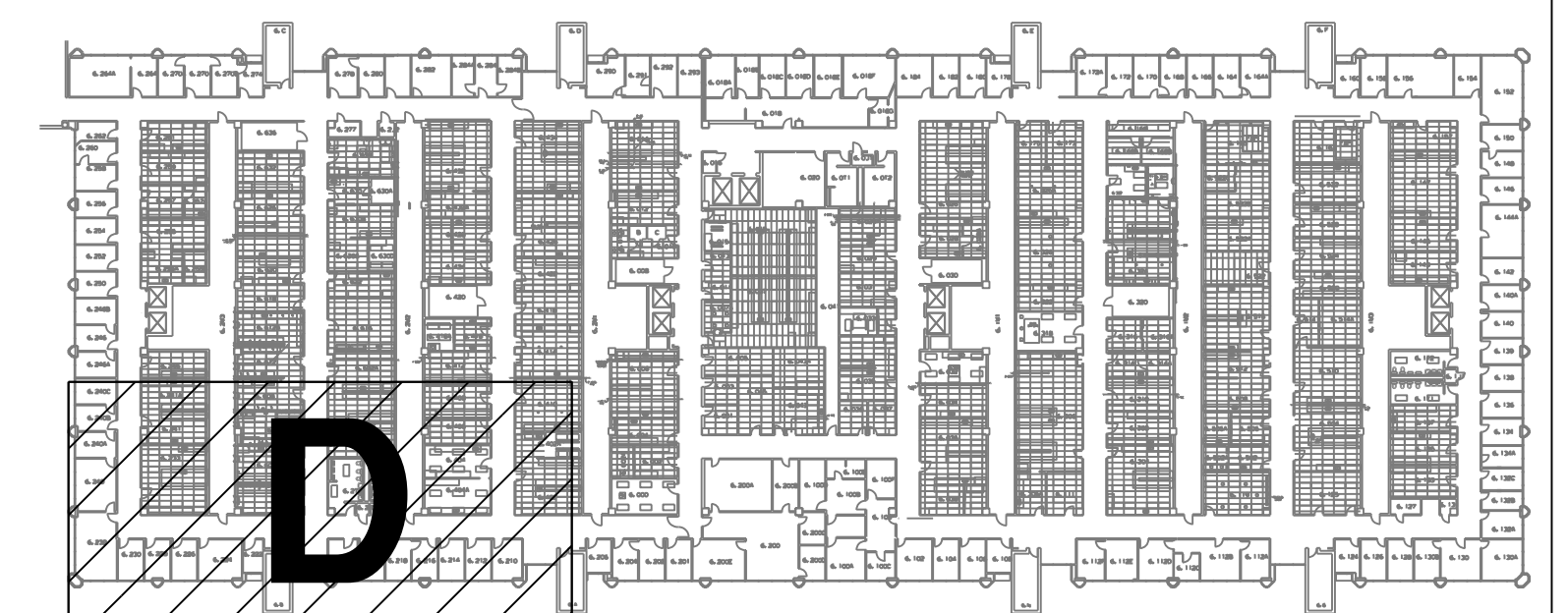

1 MECHANICAL RENO AREA D PLAN

SCALE: 1/8" = 1'-0"

UTHSC MSB OFFICE AIR DISTRIBUTION-6TH FLOOR

E&C PROJECT # 3300

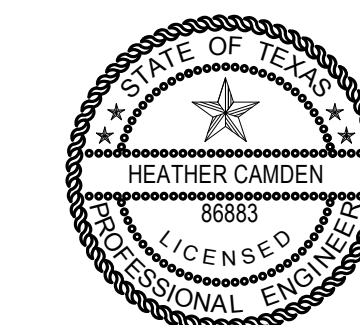

THE SEAL APPEARING ON THIS DRAWING WAS AUTHORIZED BY:
Digitally signed by Heather Camden
Date: 2017.03.03 11:00:55-06'00'
E&C Engineers & Consultants Inc.
Texas Firm Registration No: F-003068

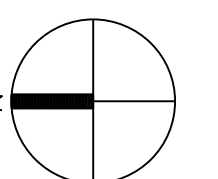

E&C
Engineers & Consultants Inc.
TX Firm Registration No: F-003068
1010 Lamar, Suite 650
Houston, Texas 77002
Tel 713/580-8800
Fax 713/580-8888
www.eceng.com

SKETCH: RENO AREA D
DRAWING: M 2.64
REVISION: CONSTRUCTION
SCALE: 1/8"=1'-0"
DATE: 03-03-2017

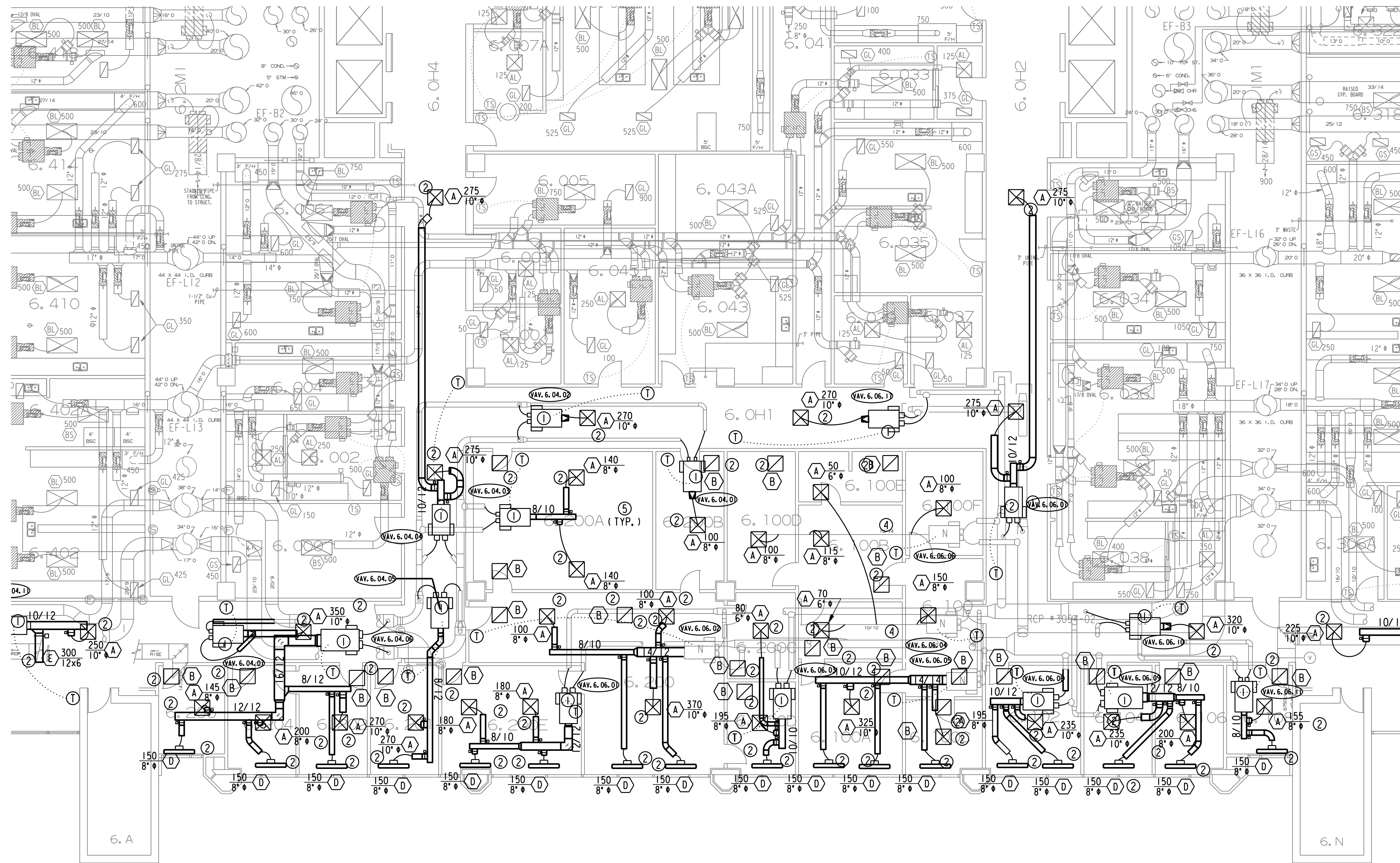

GENERAL NOTES:

- A. THE INTENT OF THE DRAWINGS IS NOT TO RELOCATE SPRINKLER HEADS OR FA DEVICES. IF NEW LIGHT OR DIFFUSER LOCATION DOES NOT WORK WITH EXISTING SPRINKLER/FA DEVICE, PLEASE CONTACT ENGINEER OF RECORD FOR FURTHER DIRECTION.
- B. PROVIDE ALTERNATE PRICING (ALTERNATE NUMBER 1) TO PROVIDE MOTION SENSORS. IN EVERY OFFICE. MOTION SENSORS SHALL BE TO TIE INTO THE BAS TO CONTROL OCCUPIED /UNOCCUPIED MODE.

DRAWING NOTES:

- ① INSTALL NEW DUAL DUCT BOX WITH CONTROLS, DUCT, FLEX, AND DIFFUSERS AS SHOWN AND SPECIFIED.
- ② PROVIDE NEW FLEX AND DIFFUSER AS NOTED.
- ③ TAP EXISTING DUCT FOR NEW DIFFUSER
- ④ VERIFY EXISTING DUCT SIZE AND NOTE ON AS-BUILTS.
- ⑤ IF ALTERNATE 1 IS TAKEN, REFER TO DRAWING PLAN AS NEEDED FOR DIFFUSER LOCATIONS.

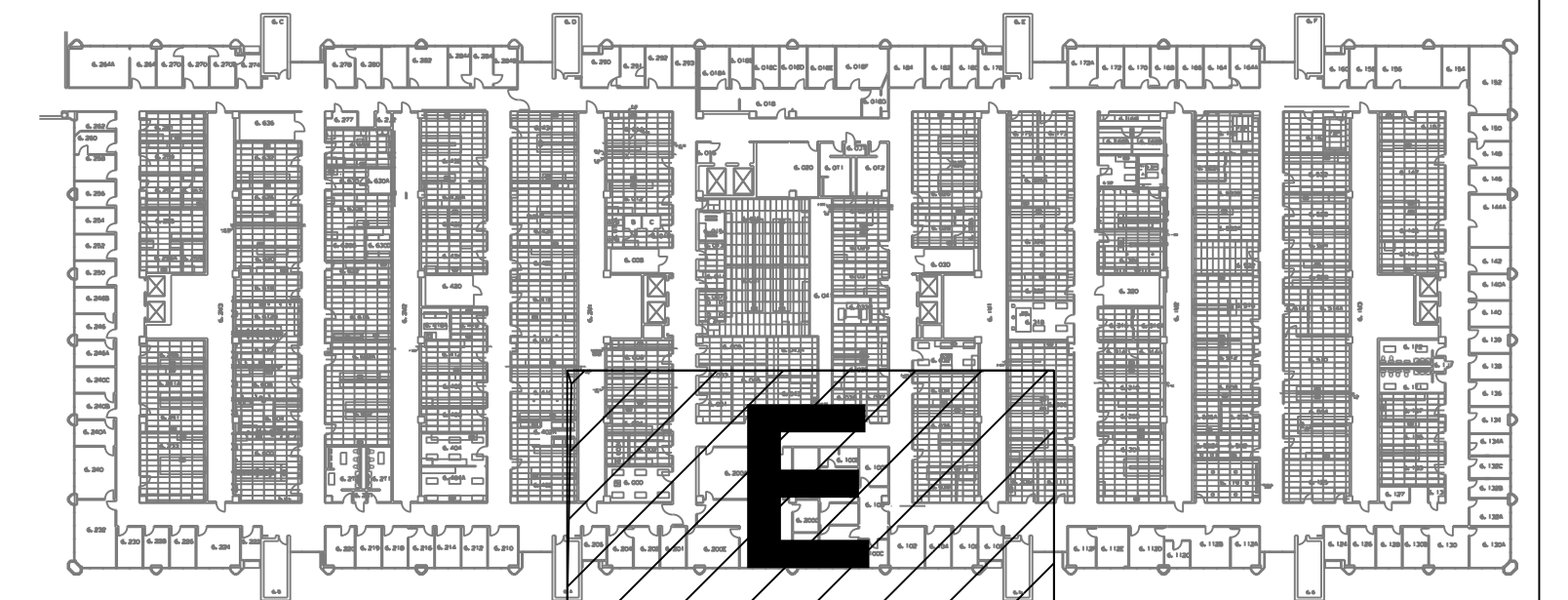

1 MECHANICAL RENO AREA E PLAN
SCALE: 1/8" = 1'-0"

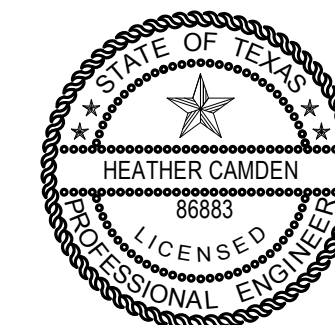

THE SEAL APPEARING ON THIS DRAWING WAS AUTHORIZED BY:
Digitally signed by Heather Camden
Date: 2017.03.03 11:00:55-06'00'
E&C Engineers & Consultants Inc.
Texas Firm Registration No: F-003068

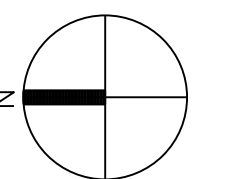

E&C
Engineers & Consultants Inc.
TX Firm Registration No: F-003068
1010 Lamar, Suite 650
Houston, Texas 77002
Tel 713/580-8800
Fax 713/580-8888
www.eceng.com

**UTHSC
MSB OFFICE AIR DISTRIBUTION-6TH FLOOR**

E&C PROJECT # 3300

SKETCH: RENO AREA E
DRAWING: M 2.65
REVISION: CONSTRUCTION
SCALE: 1/8"=1'-0"
DATE: 03-03-2017

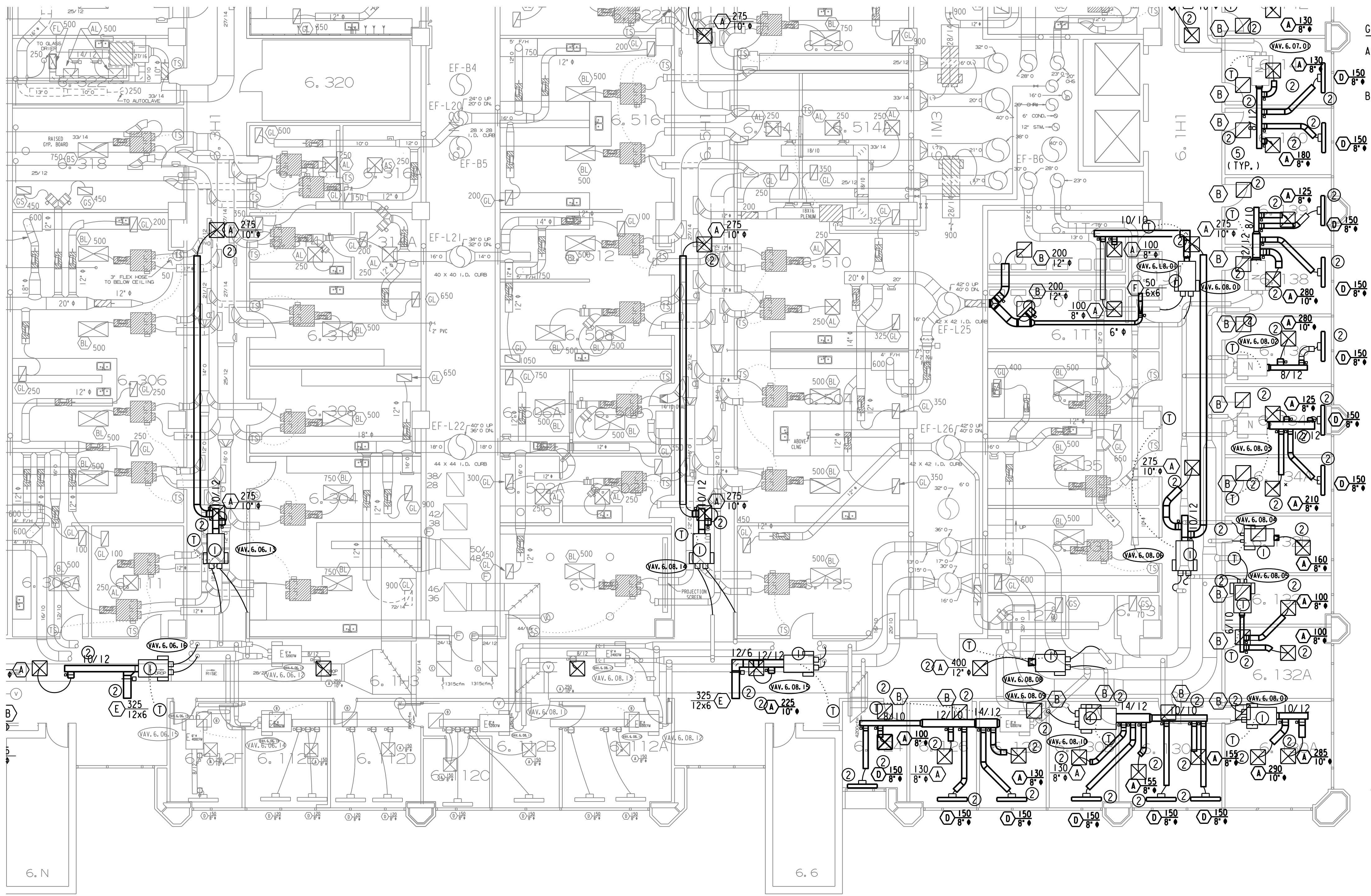

GENERAL NOTES:

- A. THE INTENT OF THE DRAWINGS IS NOT TO RELOCATE SPRINKLER HEADS OR FA DEVICES. IF NEW LIGHT OR DIFFUSER LOCATION DOES NOT WORK WITH EXISTING SPRINKLER/FA DEVICE, PLEASE CONTACT ENGINEER OF RECORD FOR FURTHER DIRECTION.
- B. PROVIDE ALTERNATE PRICING (ALTERNATE NUMBER 1) TO PROVIDE MOTION SENSORS. IN EVERY OFFICE. MOTION SENSORS SHALL BE TO TIE INTO THE BAS TO CONTROL OCCUPIED /UNOCCUPIED MODE.

DRAWING NOTES:

- ① INSTALL NEW DUAL DUCT BOX WITH CONTROLS, DUCT, FLEX, AND DIFFUSERS AS SHOWN AND SPECIFIED.
- ② PROVIDE NEW FLEX AND DIFFUSER AS NOTED.
- ③ TAP EXISTING DUCT FOR NEW DIFFUSER
- ④ VERIFY EXISTING DUCT SIZE AND NOTE ON AS-BUILTS.
- ⑤ IF ALTERNATE 1 IS TAKEN, REFER TO DRAWING PLAN AS NEEDED FOR DIFFUSER LOCATIONS.

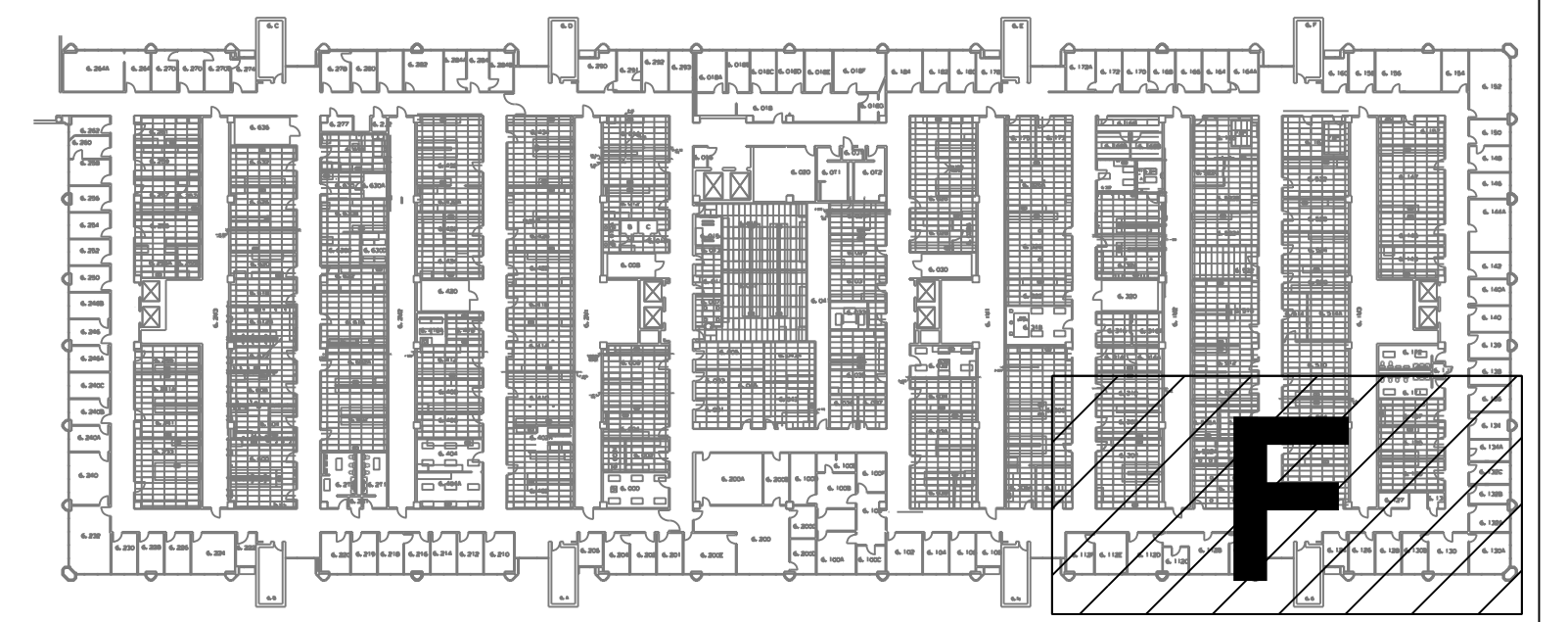

1 MECHANICAL RENO AREA F PLAN
 SCALE: 1/8" = 1'-0"

E&C
 Engineers & Consultants Inc.
 TX Firm Registration No: F-003068
 1010 Lamar, Suite 650
 Houston, Texas 77002
 Tel 713/580-8800
 Fax 713/580-8888
 www.eceng.com

**UTHSC
 MSB OFFICE AIR DISTRIBUTION-6TH FLOOR**

E&C PROJECT # 3300



THE SEAL APPEARING ON THIS DRAWING WAS AUTHORIZED BY:
 Digitally signed by Heather Camden
 Date: 2017.03.03 11:00:55-06'00'
 E&C Engineers & Consultants Inc.
 Texas Firm Registration No: F-003068

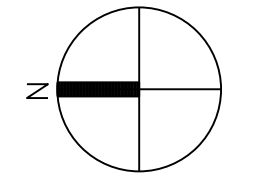

SKETCH: RENO AREA F
DRAWING: M 2.66
REVISION: CONSTRUCTION
SCALE: 1/8"=1'-0"
DATE: 03-03-2017

SUPPLY AIR DUAL DUCT TERMINAL UNIT SCHEDULE

Table with columns: UNIT NO., SERVICE, MAX COOLING CFM, MAX HEATING CFM, MIN CFM, INLET (COLD, HOT), OUTLET, MAX PD IN. WC, REMARKS. Rows include units like MSB VAV 6-01-01 through 6-01-12.

NAILOR BOX SHALL BE BOTTOM ACCESS.

SUPPLY AIR DUAL DUCT TERMINAL UNIT SCHEDULE

Table with columns: UNIT NO., SERVICE, MAX COOLING CFM, MAX HEATING CFM, MIN CFM, INLET (COLD, HOT), OUTLET, MAX PD IN. WC, REMARKS. Rows include units like MSB VAV 6-02-01 through 6-02-12.

NAILOR BOX SHALL BE BOTTOM ACCESS.

SUPPLY AIR DUAL DUCT TERMINAL UNIT SCHEDULE

Table with columns: UNIT NO., SERVICE, MAX COOLING CFM, MAX HEATING CFM, MIN CFM, INLET (COLD, HOT), OUTLET, MAX PD IN. WC, REMARKS. Rows include units like MSB VAV 6-03-01 through 6-03-12.

NAILOR BOX SHALL BE BOTTOM ACCESS.

SUPPLY AIR DUAL DUCT TERMINAL UNIT SCHEDULE

Table with columns: UNIT NO., SERVICE, MAX COOLING CFM, MAX HEATING CFM, MIN CFM, INLET (COLD, HOT), OUTLET, MAX PD IN. WC, REMARKS. Rows include units like MSB VAV 6-04-01 through 6-04-11.

NAILOR BOX SHALL BE BOTTOM ACCESS.

SUPPLY AIR DUAL DUCT TERMINAL UNIT SCHEDULE

Table with columns: UNIT NO., SERVICE, MAX COOLING CFM, MAX HEATING CFM, MIN CFM, INLET (COLD, HOT), OUTLET, MAX PD IN. WC, REMARKS. Rows include units like MSB VAV 6-18-01.

NAILOR BOX SHALL BE BOTTOM ACCESS.

AIR DISTRIBUTION DEVICE SCHEDULE

Table with columns: UNIT NO., SERVICE, TYPE, FINISH, NECK (DIAMETER IN., SQUARE IN.), FACE, MANUFACTURER, MODEL/SERIES, REMARKS. Rows include devices A through F.

SUPPLY AIR DUAL DUCT TERMINAL UNIT SCHEDULE

Table with columns: UNIT NO., SERVICE, MAX COOLING CFM, MAX HEATING CFM, MIN CFM, INLET (COLD, HOT), OUTLET, MAX PD IN. WC, REMARKS. Rows include units like MSB VAV 6-05-01 through 6-05-17.

NAILOR BOX SHALL BE BOTTOM ACCESS.

EXHAUST AIR SINGLE DUCT TERMINAL UNIT SCHEDULE

Table with columns: UNIT NO., SERVICE, MAX CFM, MIN CFM, INLET, OUTLET, MAX PD IN. WC, REMARKS. Rows include units like MSB CEV 6-05-08.

SUPPLY AIR DUAL DUCT TERMINAL UNIT SCHEDULE

Table with columns: UNIT NO., SERVICE, MAX COOLING CFM, MAX HEATING CFM, MIN CFM, INLET (COLD, HOT), OUTLET, MAX PD IN. WC, REMARKS. Rows include units like MSB VAV 6-06-01 through 6-06-16.

NAILOR BOX SHALL BE BOTTOM ACCESS.

SUPPLY AIR DUAL DUCT TERMINAL UNIT SCHEDULE

Table with columns: UNIT NO., SERVICE, MAX COOLING CFM, MAX HEATING CFM, MIN CFM, INLET (COLD, HOT), OUTLET, MAX PD IN. WC, REMARKS. Rows include units like MSB VAV 6-07-01 through 6-07-16.

NAILOR BOX SHALL BE BOTTOM ACCESS.

SUPPLY AIR DUAL DUCT TERMINAL UNIT SCHEDULE

Table with columns: UNIT NO., SERVICE, MAX COOLING CFM, MAX HEATING CFM, MIN CFM, INLET (COLD, HOT), OUTLET, MAX PD IN. WC, REMARKS. Rows include units like MSB VAV 6-08-01 through 6-08-15.

NAILOR BOX SHALL BE BOTTOM ACCESS.



E&C Engineers & Consultants Inc. TX Firm Registration No: F-003068 1010 Lamar, Suite 650 Houston, Texas 77002 Tel 713/580-8800 Fax 713/580-8888 www.eceng.com

UTHSC MSB OFFICE AIR DISTRIBUTION-6TH FLOOR

E&C PROJECT # 3300

SKETCH: MECHANICAL SCHEDULES DRAWING: M4.01 REVISION: CONSTRUCTION SCALE: NONE DATE: 03-03-2017

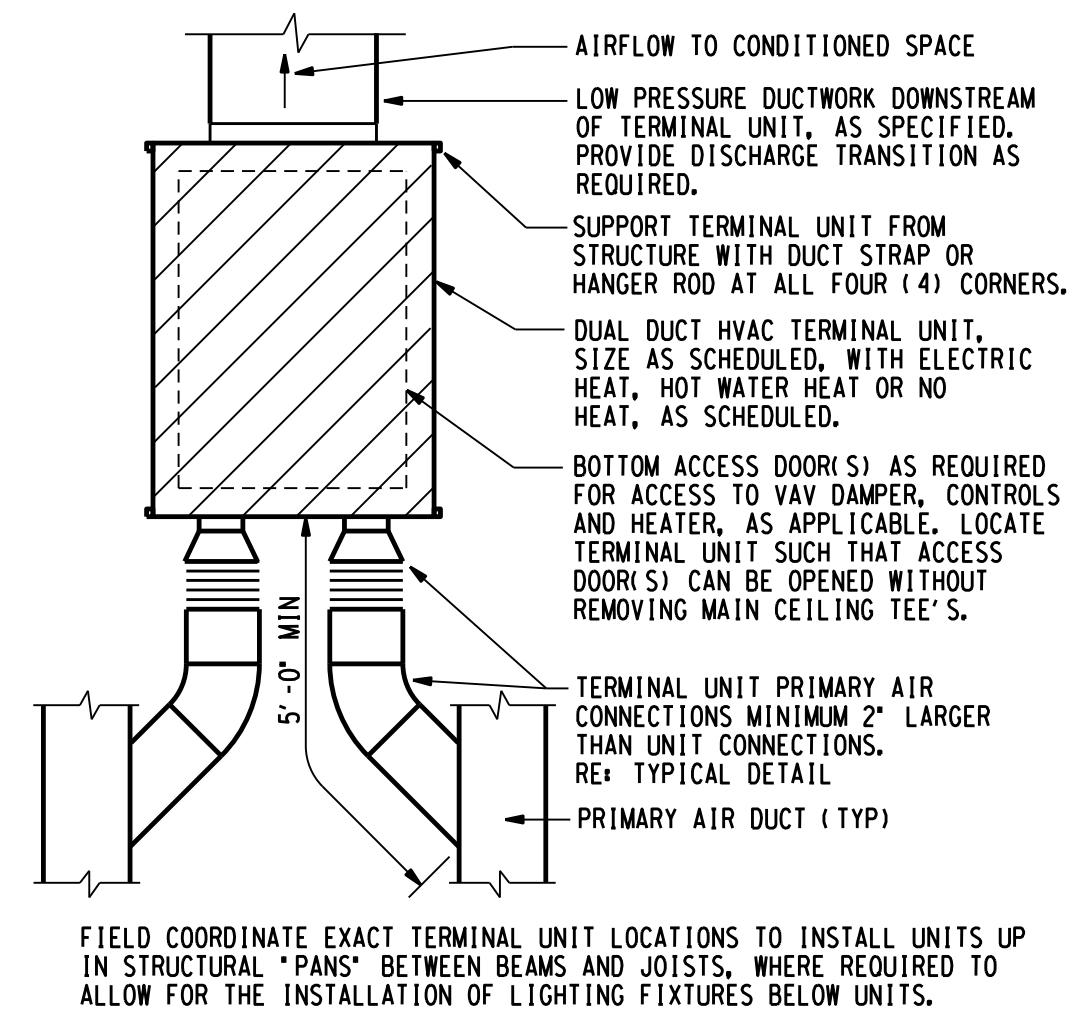

01 TYPICAL DOUBLE DUCT HVAC TERMINAL UNIT
NOT TO SCALE

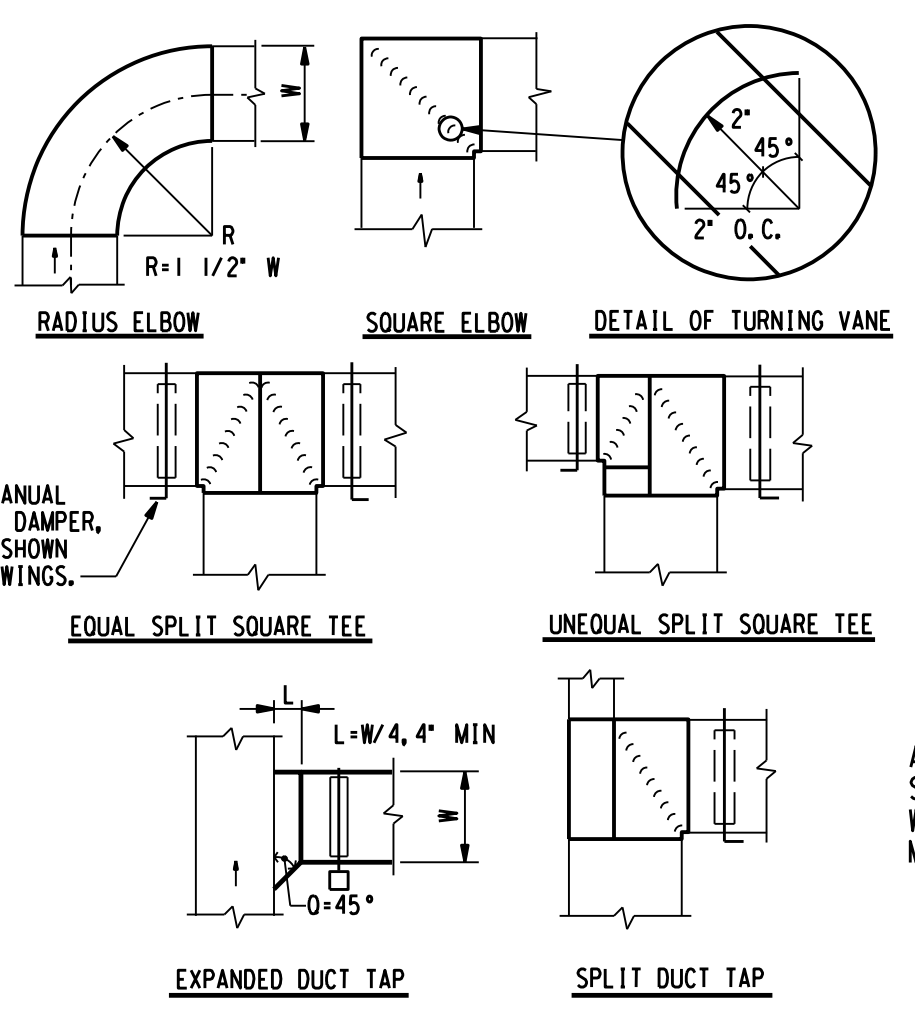

03 TYPICAL DUCT FITTINGS
NOT TO SCALE

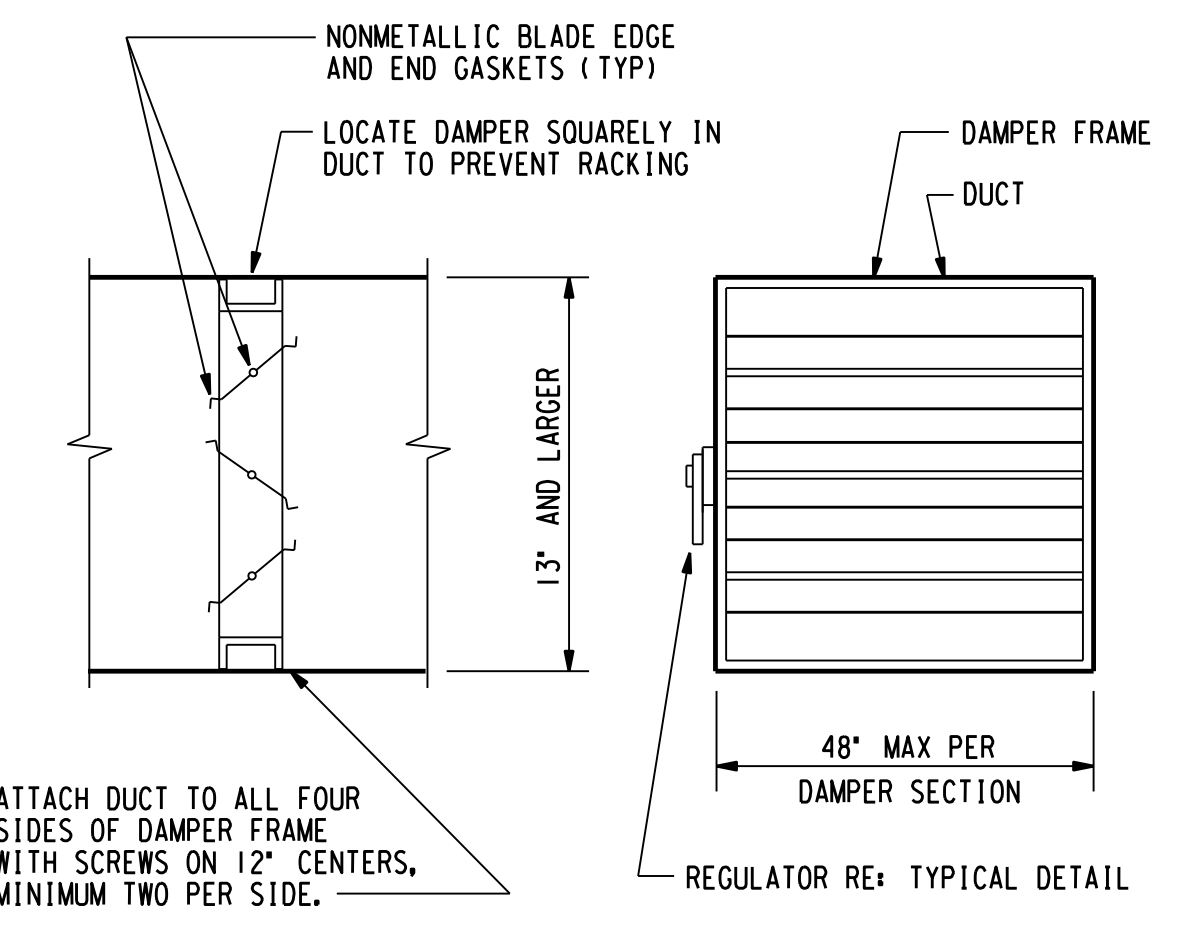

05 TYPICAL DUCT MOUNTED OPPOSED BLADE BALANCING DAMPERS
NOT TO SCALE

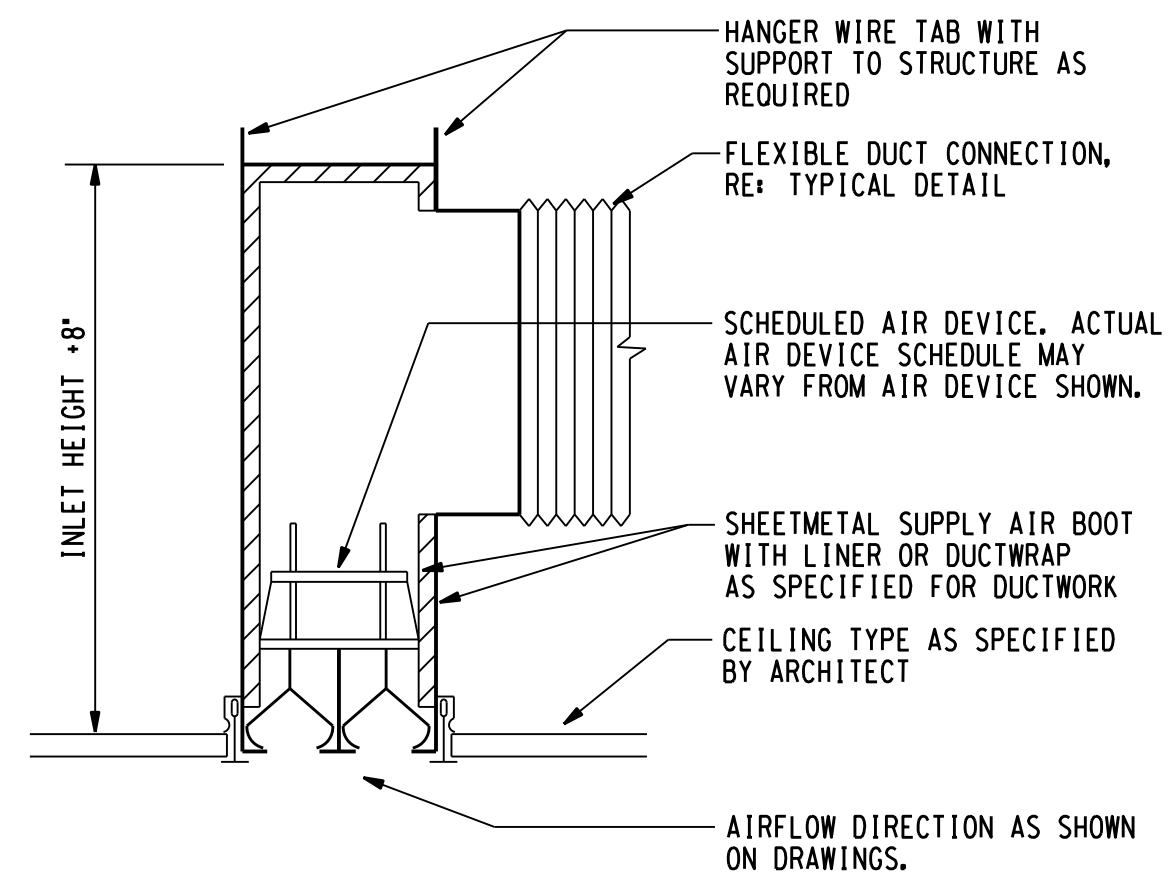

07 TYPICAL LINEAR SUPPLY AIR SLOT DIFFUSER
NOT TO SCALE

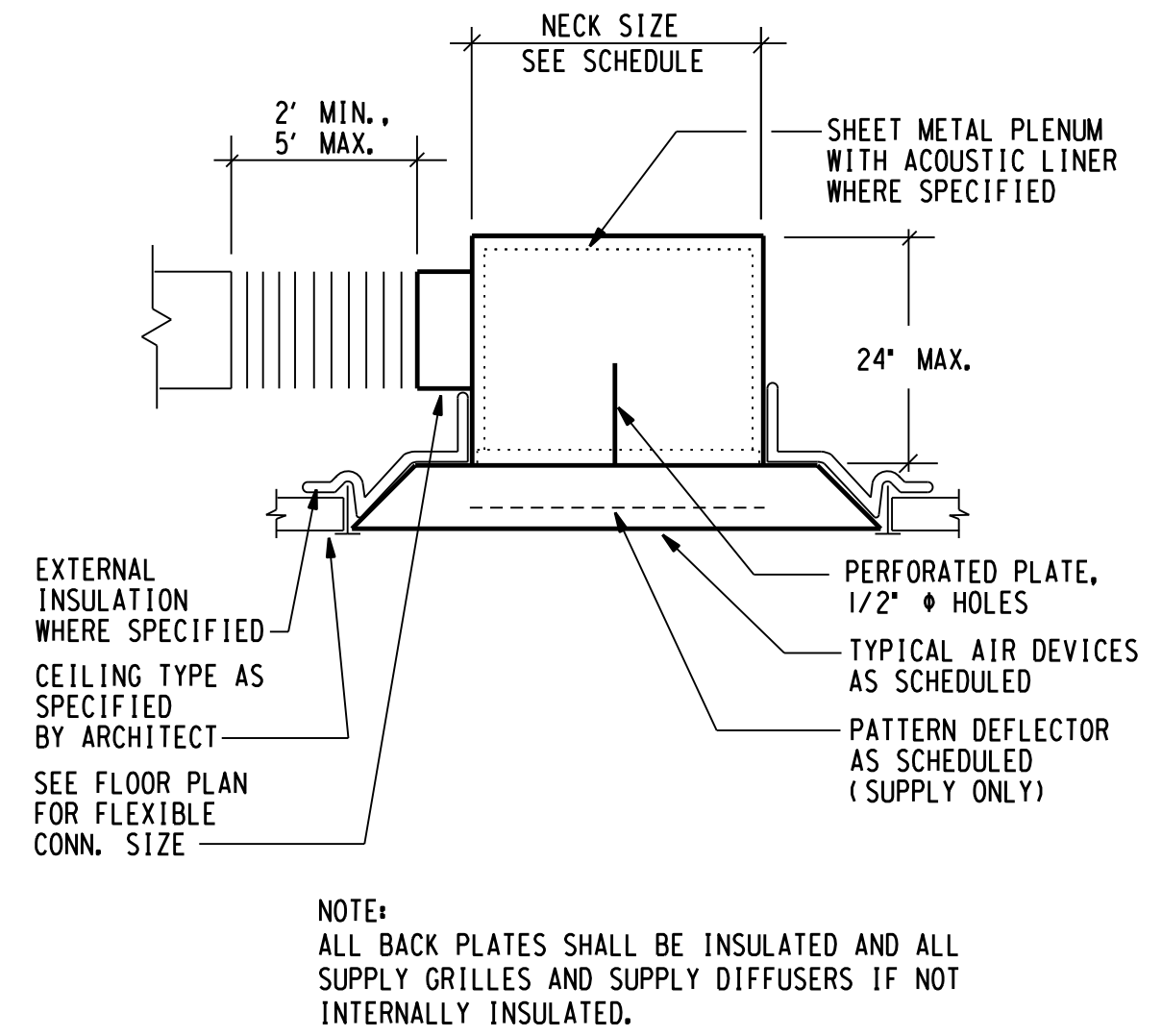

02 DIFFUSER DETAIL
NOT TO SCALE

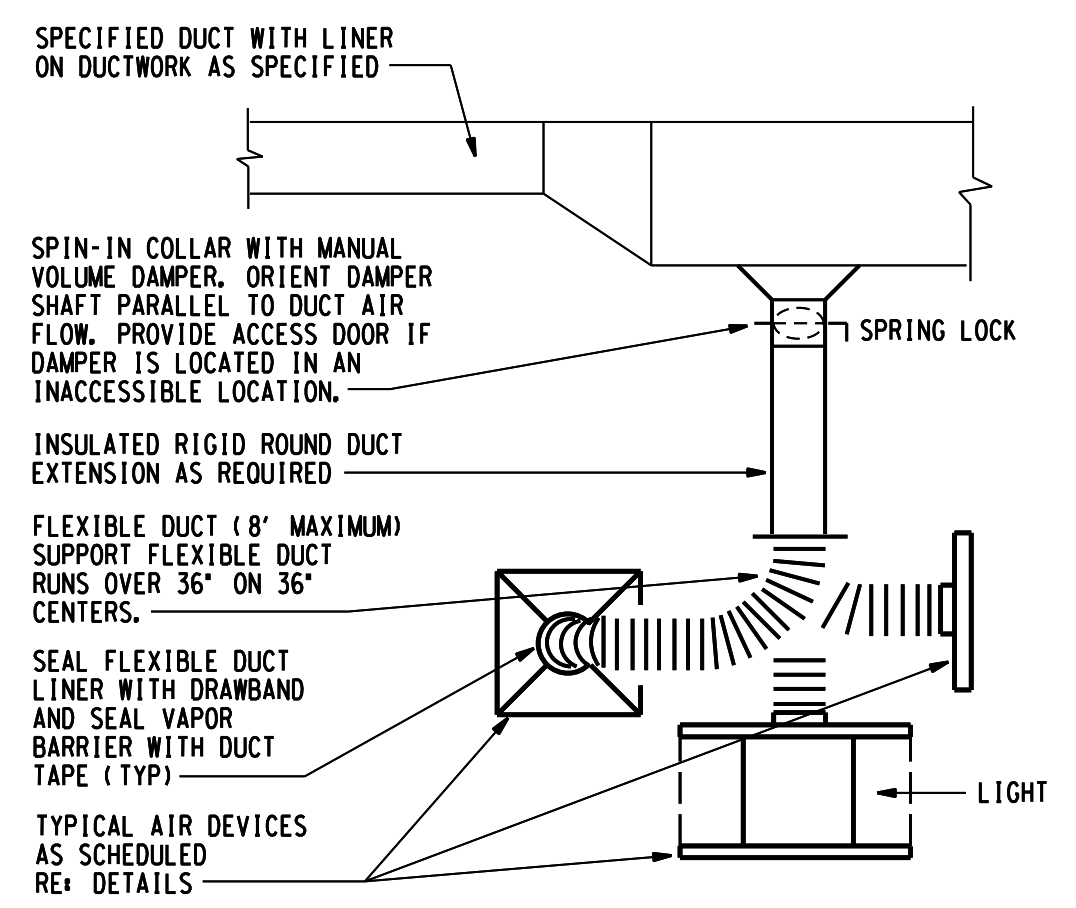

04 TYPICAL AIR DEVICE FLEXIBLE CONNECTION
NOT TO SCALE

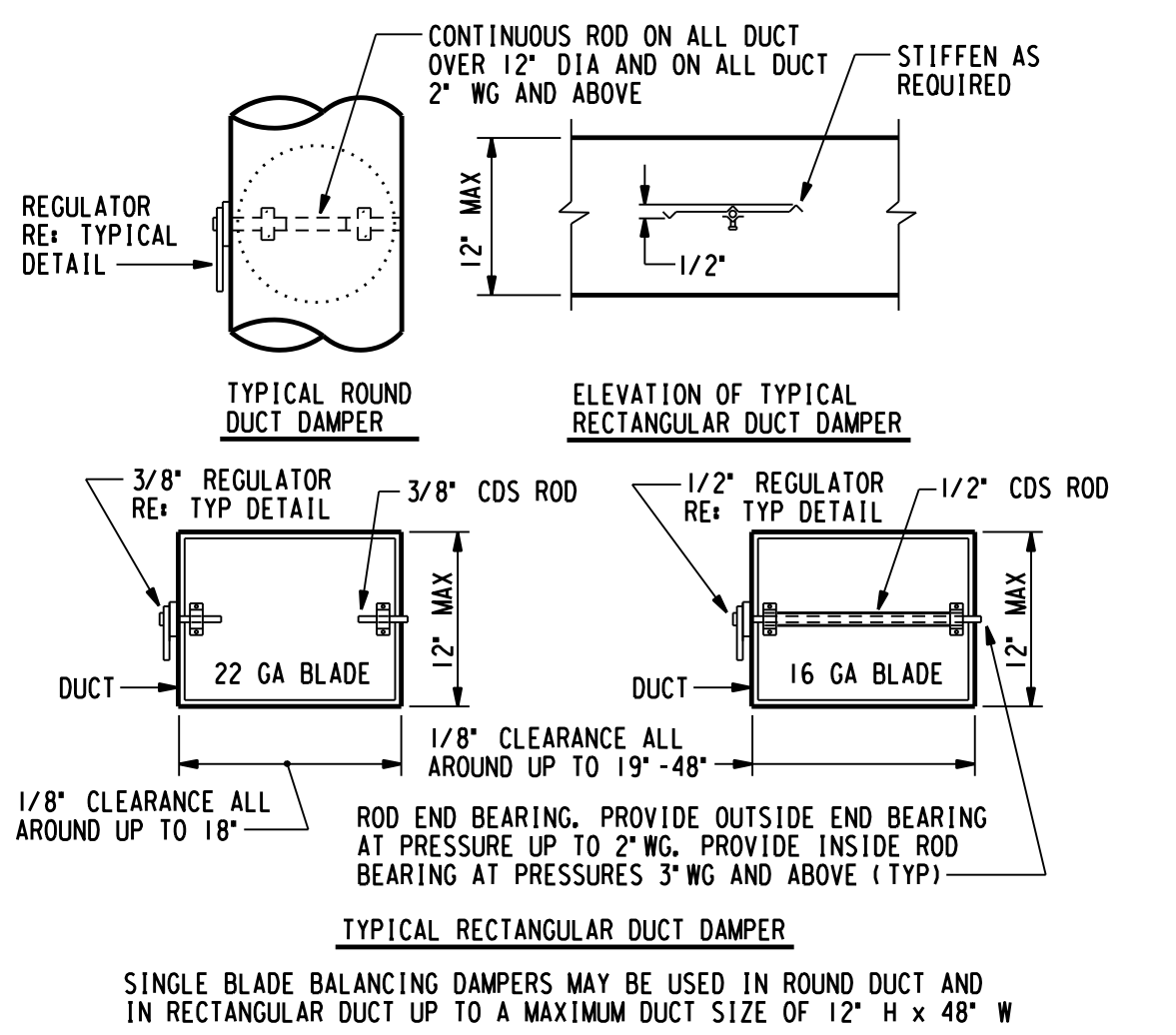

06 TYPICAL DUCT MOUNTED SINGLE BLADE BALANCING DAMPERS
NOT TO SCALE

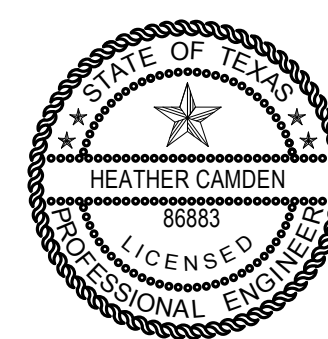

THE SEAL APPEARING ON THIS DRAWING WAS AUTHORIZED BY:
Digitally signed by Heather Camden
Date: 2017.03.03 11:00:55-06'00'
E&C Engineers & Consultants Inc.
Texas Firm Registration No: F-003068

E&C
Engineers & Consultants Inc.
TX Firm Registration No: F-003068
1010 Lamar, Suite 650
Houston, Texas 77002
Tel 713/580-8800
Fax 713/580-8888
www.eceng.com

UTHSC
MSB OFFICE AIR DISTRIBUTION-6TH FLOOR

E&C PROJECT # 3300

SKETCH: MECHANICAL
DRAWING: M5.01
REVISION: CONSTRUCTION
SCALE: 1/8"=1'-0"
DATE: 03-03-2017

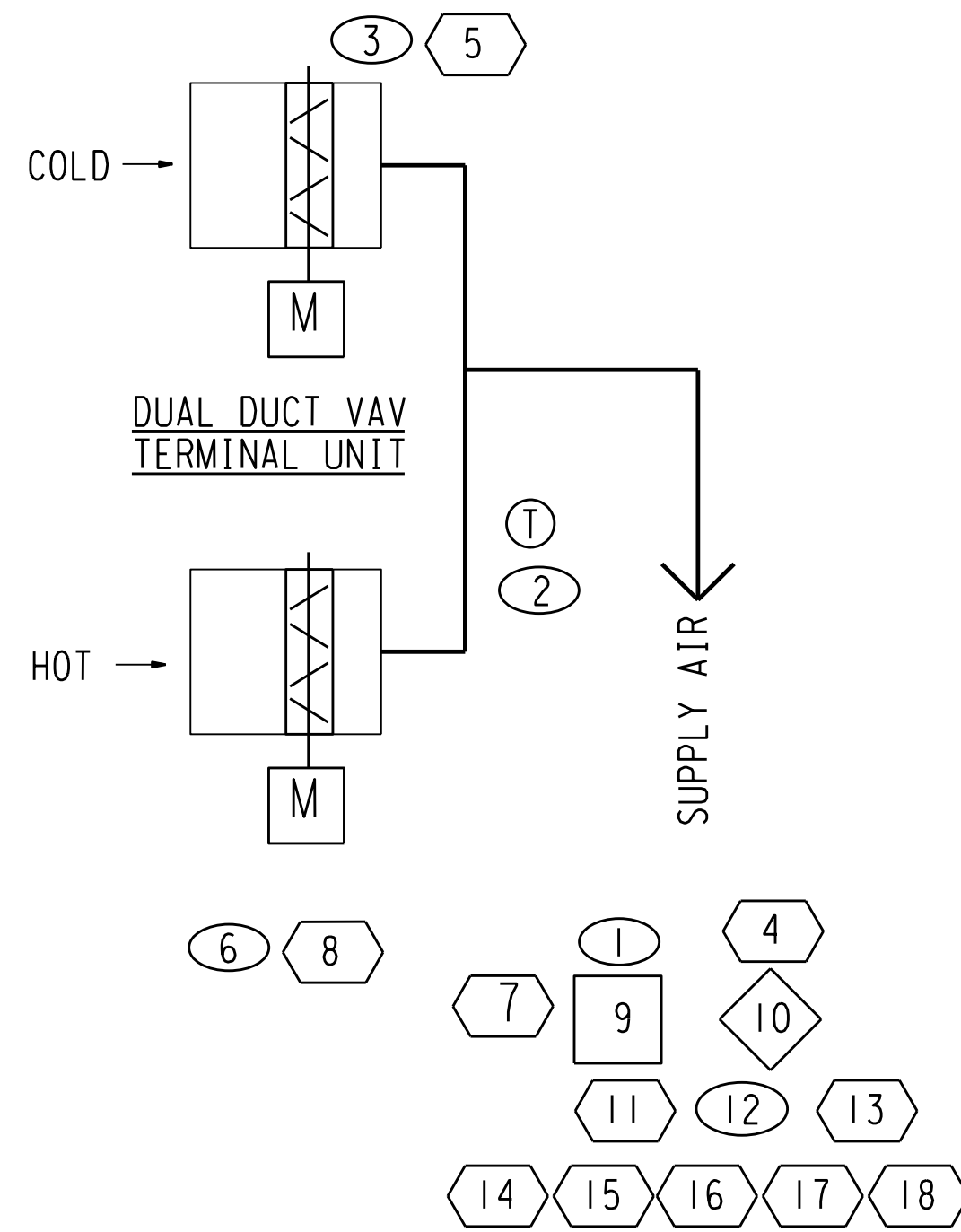

ITEM	DESCRIPTION	CONTROL SIGNAL TYPE	ALARM
1	ZONE TEMPERATURE SETPOINT	A/I	
2	ZONE TEMPERATURE	A/I	X
3	PRIMARY COLD AIR FLOW RATE	A/I	X
4	PRIMARY COLD DECK AIRFLOW SETPOINT	A/I	
5	COLD DECK DAMPER COMMAND	A/O	
6	PRIMARY HOT AIR FLOW RATE	A/I	X
7	HOT DECK FLOW SETPOINT	A/I	
8	HOT DECK DAMPER COMMAND	A/O	
9	OCCUPANCY COMMAND	M/O	
10	OCCUPANCY FEEDBACK	D/I	
11	AUTO CALIBRATE COMMAND	A/O	
12	AUTOCALIBRATE SETPOINT	A/I	
13	EFFECTIVE HEATING SETPOINT	A/O	
14	EFFECTIVE COOLING SETPOINT	A/O	
15	OCCUPIED HEATING SETPOINT	A/O	
16	OCCUPIED COOLING SETPOINT	A/O	
17	UNOCCUPIED HEATING SETPOINT	A/O	
85	UNOCCUPIED COOLING SETPOINT	A/O	

1 DUAL DUCT VAV TERMINAL UNITS

NTS

DUAL DUCT VARIABLE AIR VOLUME TERMINAL UNITS:

A. The VAV boxes shall modulate the hot and cold deck volume dampers from the scheduled maximum to the scheduled minimum primary air flow noted on the drawings as required to maintain the temperature setpoint. When the cold deck primary air has reached the minimum setpoint and heating is still required, the hot deck damper and the cold deck damper shall modulate to maintain minimum flow while mixing the two airstreams. Once the cold deck is fully closed, the hot deck may continue to open as needed to maintain room temperature.

B. In unoccupied mode, the temperature may be controlled to a larger offset between heating and cooling. The offset shall be user adjustable.

C. PLEASE ALSO INCLUDE PRICING FOR THE ADDITION OF TWO NETWORK AUTOMATION ENGINES (2 NAE) TO PICK UP ALL ADDITIONAL POINTS. CONTRACTOR TO COORDINATE REQUIRED CONTROL POWER AND LOCATION WITH UTHSC. - REFER TO FLOOR PLAN FOR APPROXIMATE LOCATIONS.

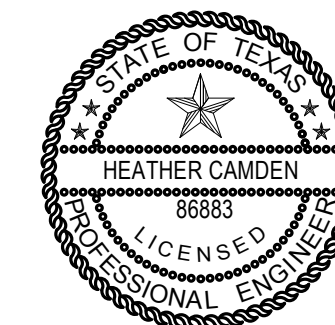

THE SEAL APPEARING ON THIS DRAWING WAS AUTHORIZED BY:
 Digitally signed by Heather Camden
 Date: 2017.03.03 11:00:55-06'00'
 E&C Engineers & Consultants Inc.
 Texas Firm Registration No: F-003068